



LITTLE BROAD RUN LANDFILL-CCR LOCATION RESTRICTION EVALUATION

Mountaineer Plant
Graham Station Road
Mason County
New Haven, West Virginia

October 18, 2016

**LITTLE BROAD RUN
LANDFILL-CCR
LOCATION
RESTRICTION
EVALUATION**



Everett Fortner III, PG
Senior Geologist

Mountaineer Plant, Graham Station
Road, Mason County, New Haven, WV

Prepared for:
American Electric Power Service Corporation



Matthew J. Lamb
Project Manager

Prepared by:
Arcadis U.S., Inc.
100 E Campus View Boulevard
Suite 200
Columbus
Ohio 43235-1447
Tel 614 985 9100
Fax 614 985 9170

Our Ref.:
OH015976.0009

Date:
October 18, 2016



John Holm, PE
Principal Engineer

This document is intended only for the use of the individual or entity for which it was prepared and may contain information that is privileged, confidential and exempt from disclosure under applicable law. Any dissemination, distribution or copying of this document is strictly prohibited.

CONTENTS

Acronyms and Abbreviations.....	iv
1. Objective	1
2. Background Information.....	2
2.1 Facility Location Description	2
2.2 Description of LBR Landfill CCR Unit.....	2
2.2.1 Landfill Configuration.....	2
2.2.2 Area/Volume.....	2
2.2.3 Construction and Operational History	2
2.2.4 Surface Water Control.....	3
2.3 Previous Investigations.....	4
2.4 Hydrogeologic Setting.....	5
2.4.1 Climate and Water Budget	5
2.4.2 Regional and Local Geologic Setting	5
2.4.2.1 Unconsolidated.....	5
2.4.2.2 Bedrock.....	6
2.4.3 Surface Water and Surface Water Groundwater Interactions.....	6
2.4.4 Water Users.....	7
3. Isolation from the Uppermost Aquifer	8
3.1 Uppermost Aquifer and Piezometric Analysis	8
3.1.1 Piezometric Analysis	8
3.1.1.1 Horizontal and Vertical Position Relative to CCR Unit	8
3.1.1.2 Overall Flow Conditions.....	9
3.1.2 Uppermost Aquifer.....	9
3.1.2.1 CCR Rule Definition.....	9
3.1.2.2 Common Definitions	10
3.1.3 Identified Onsite Hydrostratigraphic Unit.....	10
3.2 Compliance with Isolation Distance	10
4. Wetlands	11
4.1 Local Wetlands	11

LITTLE BROAD RUN LANDFILL-CCR LOCATION RESTRICTION EVALUATION

4.2 Compliance with Wetland Restrictions	11
5. Fault Areas.....	12
5.1 Description of Regional Geologic Structural Features.....	12
5.2 Compliance with Fault Area Restrictions	12
6. Seismic Impact Zone	13
6.1 Definition of Seismic Impact Zone	13
6.2 Compliance with Seismic Impact Zone Restriction.....	13
7. Unstable Areas.....	14
7.1 Definition of Unstable Area and local Conditions.....	14
7.1.1 CCR Rule Definition	14
7.1.2 Poor Foundation Soils	14
7.1.3 Mass Movements	14
7.1.4 Karst	14
7.1.5 Subsurface Mining.....	14
7.2 Compliance with Unstable Areas Restriction.....	15
8. Summary, Conclusions, and PE Certification	16
9. References.....	17

TABLE

Table 1. Water Level Data

FIGURES

Figure 1. Site Location Map

Figure 2. Plant and CCR Unit Location Map

Figure 3. LBR Landfill Layout and Well Location Map

Figure 4. Cross Section Location Map

Figure 5A. Cross Section A-A'

Figure 5B. Cross Section B-B'

Figure 6. Potentiometric Surface Map - Uppermost Aquifer, October 2001

Figure 7. Surface Water Features

LITTLE BROAD RUN LANDFILL-CCR LOCATION RESTRICTION EVALUATION

Figure 8. Nearby Fault Locations

Figure 9. Seismic Impact Zones

Figure 10. Nearby Landslides and Related Features

Figure 11. West Virginia Karst Areas

APPENDICES

- A Boring/Well Construction Logs
- B Banks Well Inventory Report

ACRONYMS AND ABBREVIATIONS

AEP	American Electric Power Service Corporation
Arcadis	Arcadis U.S., Inc.
CCR	Coal Combustion Residual
CFR	Code of Federal Regulations
EPRI	Electric Power Research Institute
FGD	flue gas desulfurization
ft	feet
LBR	Little Broad Run
LCS	Leachate Collection System
USGS	United States Geological Survey
WVDOH	West Virginia Department of Health

1. OBJECTIVE

This report was prepared by Arcadis U.S., Inc. (Arcadis) for American Electric Power Service Corporation (AEP) to assess location of the Little Broad Run (LBR) Landfill relative to the location restrictions included in the Coal Combustion Residual (CCR) requirements, as specified in Code of Federal Regulations (CFR) 40 CFR 257.60 to 257.64, for the LBR Landfill at the AEP Generating Plant (Plant) located on Graham Station Road in New Haven, West Virginia (**Figure 1**). The CCR requirements include an evaluation of the adequacy of the groundwater monitoring well network to characterize groundwater quality up and down gradient of the CCR unit and an evaluation of whether the CCR unit meets up to 5 location restrictions. The restrictions include: 1) the base of the CCR unit is 5 feet (ft) above and isolated from the uppermost aquifer, and the CCR unit may not be 2) located in a wetland, 3) within 200 ft of the damage zone of a fault that has displacement during the Holocene, 4) within a seismic impact zone, or 5) in an unstable area.

Two regulated CCR units associated with the Plant were identified for review, which include the bottom ash ponds and the LBR Landfill (**Figure 2**). This report summarizes the evaluation of the location restriction criteria at the LBR Landfill (Site). The evaluation of the groundwater monitoring well network in the uppermost aquifer is not included in this report and will be completed under separate cover.

This evaluation included a review of AEP-provided data associated with previously completed subsurface investigation activities in the vicinity of the LBR Landfill CCR unit, as well as publicly-available geologic, hydrogeologic data and recently acquired data from the additional boring and monitoring well installation related to the monitoring well network. The following report presents the current Conceptual Site Model (CSM), developed based on all available historical Site information.

2. BACKGROUND INFORMATION

The following section provides background information for the AEP Mountaineer Generating Plant LBR Landfill.

2.1 Facility Location Description

The LBR Landfill is located in Mason County approximately 2 miles southwest of the Plant and west of West Virginia Route 62 (**Figures 1 and 2**). The Site occupies approximately 660 total acres, of which 325 acres is permitted for ash disposal. The landfill is located in an isolated area, with undeveloped wooded areas to the south, east, and west.

2.2 Description of LBR Landfill CCR Unit

The following section will discuss the landfill configuration, area, volume, construction and operational history, and surface water control associated with the LBR Landfill.

2.2.1 Landfill Configuration

The landfill is situated within the drainage basin of Little Broad Run and consists of 9 planned fill areas. As of 2015, Areas 1 through 7 were either temporarily closed pending final capping, or in construction. The surface of the landfill will be covered with 2 ft of low-permeability compacted soil and vegetated with grass cover as construction at each landfill area is completed. Clay material for this cover will be derived from onsite borrow areas. General construction of the landfill is further detailed in the Vertical Expansion Engineering Design Report (Hull, 2008).

2.2.2 Area/Volume

The total area of the Site is approximately 660 acres which includes both disposal and non-disposal use. The current permitted area for disposal is 297 acres, with a total landfill disposal volume of approximately 56.5 million cubic yards, which includes both bottom ash and fly ash from both the Mountaineer and Sporn Plants (Hull, 2008) (**Figure 3**).

2.2.3 Construction and Operational History

The landfill began operation under West Virginia Department of Health (WVDOH) Permit Number 7285, dated November 16, 1978. Subsequently, the West Virginia Department of Natural Resources assumed regulatory status for the Site and operation was conducted under Application Number I-1588-L dated November 1, 1984 (Appalachian Power Company, 1984). In 1989, the pending permit Application Number I-1588-L was amended with the submission of the Class F Industrial Landfill Facility Application Addendum, Application Number WV0077038, dated September 21, 1989 (Appalachian Power Company, 1989). The landfill currently operated under Application Number WV 0077038, with addendums and/or

LITTLE BROAD RUN LANDFILL-CCR LOCATION RESTRICTION EVALUATION

renewals having been submitted in 1991, 1997, 1998, 2003, 2004, 2007, 2008, 2013, and most recently 2015.

Landfill construction is planned for 9 individual sequences (i.e. areas), with a total landfill disposal volume of approximately 56.5 million cubic yards, which includes both bottom ash and fly ash from both the Mountaineer and Sporn Plants (Hull, 2008). The Sporn Plant was de-activated on June 1, 2015 and currently does not contribute CCR material to the Site. As of 2015, Areas 1 through 7 were either temporarily closed pending final capping, or in construction.

During typical landfill construction, a liner is placed at the base of each area. Liner construction specifics have varied over time. Liners at landfill Areas 1 through 3 consist of a minimum 2-ft thick natural clay liner overlain by a single-underdrain system to collect leachate and groundwater seepage. The liner at Area 4 consists of a minimum 2-ft thick engineered clay liner overlain by a single-underdrain system, as well as a groundwater interceptor drain system beneath the clay liner to capture spring flow from perched groundwater (EPRI, 1999). Liner construction for Areas 5 through 7 is described in detail in Solid Waste/NPDES Permit No. WV0077038 Permit Renewal Application (AEP, 2003), consisting in general of the following layers:

- Groundwater interceptor drainage system
- Minimum 12-inches of compacted or in-place clayey subbase
- Minimum 24-inches of compacted clay liner
- Leachate Collection System (LCS)
- Protective cover zone

With the Sporn Plant closure in June 2015, only CCR byproducts from the Mountaineer Plant are currently placed in the landfill. These waste products include fly ash, bottom ash, flue gas desulfurization (FGD) (synthetic gypsum), and FGD purge stream treatment solids (limestone inerts and solids). The FGD and gypsum are transported to the landfill via above-ground conveyors, while fly ash and bottom ash are de-watered and removed from the Mountaineer bottom ash ponds or fly ash silo before being hauled to the landfill via private haul road. The landfill also occasionally receives CCR byproducts from the AEP Plants at Clinch River (VA), Glen Lyn (VA), and Kanawha River (WV) (AEP, 2003).

2.2.4 Surface Water Control

Surface water control at the Site is discussed in detail in Vertical Expansion Engineering Design Report (Hull, 2008). Structures are in place at the Site that control surface runoff and infiltration of surface runoff. Surface runoff is managed through a series of leachate ponds, sediment control basins, and diversion ditches that channel flow to temporary sediment collection ponds around the perimeter of the site (non-contact runoff) or the permanent leachate collection pond located to the northeast and downstream of the Little Broad Run valley (contact runoff). The two leachate ponds consist of an underdrain/groundwater interceptor system consisting of (from bottom to top) a 1.0-foot drainage layer that collects groundwater and a 4" perforated high density polyethylene (HDPE) pipe that conveys collected groundwater to a sump via gravity flow; an 8 ounce non-woven geotextile above the drainage layer; a minimum 1.5-foot compacted clayey soil liner; HDPE geomembrane, a 16 ounce non-woven geotextile above the HDPE

membrane; and a 12-inch minimum reinforced concrete base installed above the 16-ounce geotextile (Hull, 2010).

2.3 Previous Investigations

Prior to submission of the original WVDOH Permit Number 7285, AEP performed a site investigation to characterize the conditions at the proposed landfill facility. These investigations included drilling through soil and into rock, split barrel soil sampling and standard penetration testing, undisturbed soil sampling (Shelby tubes), and continuous rock coring, where appropriate (AEP Service Corp., 1978).

Soil samples were analyzed for geotechnical parameters to assist with general site characterization and stability analyses. These parameters include grain size distribution, moisture content, plasticity, and permeability (AEP Service Corp., 1978).

In 1986, AEP published the results of additional site investigations in Ground-Water Monitoring of Little Broad Run Fly Ash Landfill, New Haven, W. Va. This investigation included the installation of additional soil and rock borings, packer testing of select borings to determine hydraulic properties of the water-bearing zones, and the installation of four monitoring wells (MW-1 through MW-4) (AEP Service Corp., 1986). Approximately half of the current monitoring well network was installed in subsequent investigation activities from 1992 to 1997. These monitoring wells were routinely sampled and gauged, and the results of routine monitoring were published in landfill permit renewals in 1997, 1998, and 2003. From 2004 to 2010, the remainder of the wells and piezometers of the monitoring well network were installed and are currently sampled or gauged as part of routine Site monitoring (AEP, 2003).

From 1995 through 1998, AEP worked in coordination with Ish, Inc., META Environmental, Inc., HIS GeoTrans, Inc., and Electric Power Research Institute (EPRI) to evaluate groundwater quality associated with a number of AEP power generating facilities, including the Mountaineer Plant. The primary objectives of these site investigations were to characterize hydrogeology and identify potential contaminant source areas, establish existing groundwater quality, and identify constituents that exceeded West Virginia Groundwater Standards. These studies are described in detail in the report Groundwater Quality at the Philip Sporn and Mountaineer Power Plants, Mason County, West Virginia (EPRI, 1999). For the landfill, groundwater quality was assessed in these studies from analytical results dated April, July, and October 1997 from 24 existing wells (MW-3 to MW-9, MW-12, MW-14 to MW-22, MW-27 to MW-33).

In addition to groundwater monitoring and site characterization investigations, an evaluation of stability related to underground mining at the Philip Sporn Mine was performed in 1992 (Gales, 1992). As part of this investigation, one test hole was drilled to intercept the Pittsburg Coal seam. Samples of the coal and surrounding rock strata were collected and analyzed for mechanical properties. Additionally, pillar load calculations were performed to assess pillar strength under post-landfill construction conditions. This investigation concluded that subsidence has not occurred at the LBR Landfill, that the pillars would not fail under increased loading, and that no sensible strain would be present at the ground surface as a result of previous mining (Gales, 1992).

2.4 Hydrogeologic Setting

The hydrogeologic setting is discussed in detail in Solid Waste/NPDES Permit No. WV0077038 Permit Renewal Application (AEP, 2003). The geologic setting surrounding the Site primarily consists of the Pennsylvanian age sandstones, shales, limestones, and coal of the Monongahela Group. At higher elevations, the hilltops are capped by the Permian age Dunkard Formation, which is lithologically similar to the Monongahela Group (EPRI, 1999). Groundwater occurrence in the bedrock generally coincides with the stress relief fracture system and is not necessarily related to lithology. Fracture orientation ranges from vertical (predominantly along valley slopes) to horizontal (along bedding planes). Groundwater flow occurs primarily in this fracture network, and the lateral flow generally follows topography towards the LBR valley center. The principal direction of groundwater flow in the valley is towards the LBR valley mouth to the northeast.

Unconsolidated deposits in the vicinity of the landfill consist primarily of weathered bedrock and residuum blanketing the underlying bedrock, with some colluvial deposits consisting of weathered rock, sand, silt, and clay. Soils are generally clay-type and vary in thickness from 1.8 ft to 20.3 ft (AEP, 2003). Further down valley towards the valley mouth, alluvial deposits derived from Little Broad Run, combined with residuum, are present in thickness up to 28 ft. These alluvial sediments overlie bedrock and are in hydraulic connection to the fracture network.

These features are further illustrated on two lines of cross section that were initially prepared by AEP with modifications through the LBR landfill made by Arcadis to incorporate data obtained in 2016. One cross section trends from southwest to northeast through the landfill (A to A') and the other cross section trends from the northwest to the southeast through the landfill (B to B'). The cross section location map is included as **Figure 4** and the cross sections are included as **Figure 5A** (A to A') and **Figure 5B** (B to B'). Boring logs and well construction diagrams are included in **Appendix A**.

2.4.1 Climate and Water Budget

The climate of Mason County, West Virginia is characterized as humid continental with an average rainfall of approximately 42 inches annually. The average maximum temperature is 68 °F and the average minimum temperature is 44 °F based on information from the Southeast Regional Climate Center (SERCC, 2015).

The results of a mass balance water budget analysis performed as part of the March 2003 Solid Waste/NPDES Permit No. WV0077038 Permit Renewal Application is described in detail in Section D of that application (AEP, 2003). The primary objective of this analysis was to estimate the average annual precipitation, evapotranspiration, and leachate production (AEP, 2003).

2.4.2 Regional and Local Geologic Setting

2.4.2.1 Unconsolidated

The Site is located in the Appalachian Plateau physiographic province, and unconsolidated soils are limited in extent. Depending on geologic setting, soils are residual, colluvial, and/or alluvial in origin.

LITTLE BROAD RUN LANDFILL-CCR LOCATION RESTRICTION EVALUATION

Soils in lower topographic areas (i.e. valleys) consist of a combination of residuum derived from weathered sandstone/shale and colluvium. Adjacent to the Little Broad Run, alluvial deposits are present, consisting of silty to sandy clay. Further up the ridges, soils are composed mainly of residuum. Unconsolidated material is thickest in the valley floors. Based on historical and recent soil samples and well installation logs, the soil thickness ranges from 1.8 to 28 ft.

2.4.2.2 Bedrock

The primary regional bedrock units underlying the landfill are sedimentary rocks of the Permian age Dunkard Formation and the Pennsylvanian age Monongahela Formation. The depositional environment for these formations is characterized by a gradually subsiding shallow sea with alternating marine and freshwater strata. Sedimentary rocks associated with the Dunkard Formation, which immediately underlie unconsolidated sediments beneath the Site, consist of predominantly clay-shale with alternating beds of siltstone, sandstone, and occasionally thin limestone beds (AEP, 2003). The base of the Dunkard Formation is marked by a thick, massive conglomeritic sandstone that separates it from the deeper Monongahela Formation (EPRI, 1999). The Monongahela Formation is lithologically similar to the Dunkard Formation. Several coal horizons are present in the region and often serve as marker beds for unit identification. Locally, the Pittsburg No. 8A coal bed defines the base of the Monongahela Formation (EPRI, 1999). Bedrock occurrence is illustrated on both cross sections (**Figures 5A** and **5B**) and detailed in boring logs included in **Appendix A**.

No geologic structures have been mapped in the immediate vicinity of the Site. Regionally, a series of gently dipping anticlines and synclines strike to the north-northeast, and the Parkersburg Syncline is located approximately 11 miles to the east-southeast from the Site (AEP, 2003). The Parkersburg Syncline appears to dip to the north-northwest, and bedding planes generally dip toward the axis of the syncline. Locally, however, bedding planes are reversed due to mild up-warping, and are essentially flat lying (EPRI, 1999).

2.4.3 Surface Water and Surface Water Groundwater Interactions

One intermittent stream, Little Broad Run, occurs in the vicinity of the Site and originates at the northeastern corner of the landfill. Little Broad Run flows to the north and ultimately discharges into the Ohio River. Groundwater flow follows topographic relief and is generally in the flow direction of Little Broad Run to the northeast. Two leachate collection ponds are constructed northeast of the landfill. This system collects surface water runoff, as well as groundwater from the leachate and groundwater interceptor drain systems as well as the gypsum stack-out pad. The two leachate ponds consist of an underdrain/groundwater interceptor system consisting of (from bottom to top) a 1.0-foot drainage layer that collects groundwater and a 4" perforated high density polyethylene (HDPE) pipe that conveys collected groundwater to a sump via gravity flow; an 8 ounce non-woven geotextile above the drainage layer; a minimum 1.5-foot compacted clayey soil liner; HDPE geomembrane, a 16 ounce non-woven geotextile above the HDPE membrane; and a 12-inch minimum reinforced concrete base installed above the 16-ounce geotextile (Hull, 2010).

LITTLE BROAD RUN LANDFILL-CCR LOCATION RESTRICTION EVALUATION

The leachate collection ponds discharge water to the leachate surge pond at Mountaineer Plant. The water is pumped to the bioreactor for treatment and then pumped to the clear water pond where this water will eventually flow to outlet 001, which discharges to the Ohio River.

2.4.4 Water Users

In 2014, a water well inventory for the Mountaineer Plant indicated no information regarding the use of wells located in the vicinity of the Site was available (Banks, 2014). However, the one well that was identified was registered with the United States Geological Survey, is located at the Phillip Sporn Power Plant, and appears to be used for groundwater monitoring. A copy of the well report is included in **Appendix B**.

3. ISOLATION FROM THE UPPERMOST AQUIFER

CCR Rule 40 CFR Part 257.60 requires that the base of new and existing CCR surface impoundments be constructed such that the base of the unit is no less than 5 ft above the top of the uppermost aquifer, or that if the base is within 5 ft of the uppermost aquifer, that there will not be hydraulic connection between the base of the unit and the uppermost aquifer.

3.1 Uppermost Aquifer and Piezometric Analysis

3.1.1 Piezometric Analysis

3.1.1.1 Horizontal and Vertical Position Relative to CCR Unit

Groundwater occurrence at the Site is generally in fractured sandstone units, and have been identified as Hydrologic Units 1 through 4 in order from shallowest to deepest beneath the landfill. Hydrologic Units 1 and 2 are limited in lateral extent in this area and are restricted to higher elevations along valley walls, and likely discharge to a seepage face or local drainages in close proximity to the landfill. Therefore, these units are not sources of groundwater for wells or developed springs and thus not considered as part of the uppermost aquifer. Therefore, the uppermost aquifer at the Site is defined as the laterally extensive Hydrologic Unit 3, and in the absence of Hydrologic Unit 3 the uppermost aquifer is defined as the deeper Hydrologic Unit 4. Hydrologic Unit 3 is present throughout most of the Site; however, the bedrock unit pinches out to the northeast (in the vicinity of MW-15 and MW-20) and the southeast (between SB-1602R and MW-24/MW-25) (**Figure 5B**). Hydrologic Unit 4 pinches out to the northeast between the MW-9/MW-19/MW-32 well cluster and SB-1609R/SB-1619R, but is otherwise present underlying the landfill (**Figure 5A**). In addition to primary porosity which provides groundwater storage, secondary porosity in the form of stress relief fractures (paleo-relief) occur in both the Dunkard and Monongahela Formations. Stress relief fractures are likely hydraulically connected with deeper open horizontal bedding planes. In similar stress relief fracture systems, the aquifers are generally unconfined; however, conditions can exhibit confined behavior in valley floors if low-transmissivity sediments (i.e. clay) are present (USGS, 1981). Vertical stress relief fracture frequency decreases with depth, and fractures are less common in interbedded shale units between sandstone units (EPRI, 1999). As a result, deeper Hydrologic Units 3 and 4 exhibit confined conditions. The uppermost aquifer, consisting of Hydrologic Units 3 and/or 4, is horizontally continuous across the entire Site.

Towards the northeast valley mouth and down gradient of the landfill, Hydrologic Unit 4 is blanketed by alluvium consisting of silty to sandy clay. The alluvium and shallow weather shale bedrock occurrence continues down valley and is hydraulically connected to Hydrologic Unit 4; Therefore, these shallow units are included as part of the down gradient monitoring of the landfill. Alluvial thickness observed at MW-1611 and SB-1609R ranged from 26 to 28 ft, respectively (**Figure 5A**).

The upper limit of the uppermost aquifer is located beneath the original ground surface prior to landfill construction and is defined as the top of Hydrologic Unit 3, or the top of Hydrologic Unit 4 in the absence of Hydrologic Unit 3. The top of Hydrologic Unit 3 occurs at depths as shallow as 15 ft below ground surface (bgs) (near MW-15 and MW-20). The top of Hydrologic Unit 4 occurs at depths as shallow as 26 ft bgs (MW-1611).

3.1.1.2 Overall Flow Conditions

Groundwater flow is laterally continuous throughout most of the Site within Hydrologic Units 3 and 4. Where Hydrologic Unit 3 is no longer present, Hydrologic Unit 4 is present and continuous. Groundwater flow in these units follow historical topography towards the LBR valley bottom. Groundwater underlying the valley floor generally flows to the northeast towards the northeast valley mouth. Available groundwater elevations for Hydrologic Units 3 and 4 wells are summarized on **Table 1** from August 1993 to August 2016. Potentiometric contours from October 2001 is the most complete data set with the closed wells in the center portion of the landfill and were used to depict groundwater flow conditions (**Figure 6**). Recently installed monitoring wells MW-1611 and MW-1612 were not be used in potentiometric contouring presented on **Figure 6**; However, groundwater levels collected during from these two wells are consistent with general piezometric elevation understanding and groundwater flow directions.

Towards the northeast valley mouth down gradient of the landfill, Hydrologic Unit 4 is likely hydraulically connected to the overlying and laterally adjacent alluvium and weathered bedrock. Groundwater flow in this northeastern portion of the Site is likely towards the valley center and down valley in the direction of Little Broad Run. Available groundwater elevations for alluvium monitoring wells are summarized on **Table 1**.

Water level gauging conducted at well nests at the Site are from historical information since many of the wells are now closed. The wells nests water levels indicate downward vertical hydraulic gradients between Hydrologic Units 1 and 3 ranging from 0.39 to 0.91 ft/ft, whereas deeper vertical hydraulic gradients tend to be upwards. An upward vertical hydraulic gradient of 0.09 ft/ft was measured at the MW-20/MW-15 well pair (EPRI, 1999).

3.1.2 Uppermost Aquifer

3.1.2.1 CCR Rule Definition

Per 40 CFR 257.60(a), new CCR landfills, existing and new CCR surface impoundments, and all lateral expansions of CCR units must be constructed with a base that is located no less than 1.52 meters (approximately 5 ft) above the upper limit of the uppermost aquifer, or must demonstrate there will not be an intermittent, recurring, or sustained hydraulic connection between any portion of the base of the CCR unit and the uppermost aquifer due to normal fluctuations in groundwater elevations (including the seasonal high conditions).

The CCR rule definitions for an aquifer and the uppermost aquifer as specified in 40 CFR 257.53 indicates an aquifer is a geologic formation capable of yielding usable quantities of groundwater to wells or springs while an uppermost aquifer is defined as the geologic formation nearest the natural ground surface that is an aquifer, as well as lower aquifers, that are hydraulically interconnected with this aquifer within the facility's property boundary. Upper limit is measured at a point nearest to the natural groundwater surface to which the aquifer rises during the wet season.

3.1.2.2 Common Definitions

An aquifer is commonly defined as a geologic unit that stores and transmits water (readily or at sufficient flow rates) to supply wells and springs (USGS, 2015; Fetter, 2001). The uppermost aquifer is considered the first encountered aquifer nearest to the CCR unit.

3.1.3 Identified Onsite Hydrostratigraphic Unit

The identified Site hydrostratigraphic unit is Hydrologic Unit 3, or Hydrologic Unit 4 in the absence of Hydrologic Unit 3. This aquifer is not known to be used locally for groundwater supply or industrial water use.

3.2 Compliance with Isolation Distance

The estimated base of the CCR unit varies based on pre-construction surface topography. The upper limit of the uppermost aquifer is defined as the top of the applicable hydrologic unit, which are generally flat lying (**Figure 5A** and **Figure 5B**) beneath the landfill. In the portion of the Site where Hydrologic Unit 3 constitutes the uppermost aquifer, the elevation of the upper limit of the uppermost aquifer is shallowest in the vicinity of abandoned monitoring well MW-20, which was located in the central portion of the landfill near the intersection of Cross Sections A-A' and B-B'. At MW-20, the depth to the top of Hydrologic Unit 3 was approximately 15 ft bgs before landfill construction and approximately 15 ft below the base of the landfill liner after landfill construction (**Figure 5A**).

Based on this review of historical data, there is currently at least 15 ft of separation between the upper limit of the uppermost aquifer and the estimated base of the CCR unit. This is illustrated in cross section A-A' (**Figure 5A**). This CCR unit meets the location restriction for separation of 5 ft from the uppermost aquifer.

4. WETLANDS

CCR Rule 40 CFR Part 257.61 requires that existing and new CCR surface impoundments must not be located in wetlands.

4.1 Local Wetlands

Based on the August 12, 2015 site visit and review of available published information, the landfill is not located within any areas that exhibited wetland characteristics that might be classified as a regulated wetland. The landfill is, however, located within the Little Broad Run valley, a tributary of the Ohio River. Little Broad Run originates at the northeastern boundary of the CCR unit and flows to the northeast (**Figure 3** and **Figure 7**).

4.2 Compliance with Wetland Restrictions

Based on the August 12, 2015 site visit and review of available information, the landfill is not located within wetlands. Therefore, this CCR unit meets the location restriction regarding wetlands.

5. FAULT AREAS

CCR Rule 40 CFR Part 257.62 requires that existing and new CCR surface impoundments must not be located within 200 ft of the outermost damage zone of a fault that has had displacement in Holocene time unless the owner or operator demonstrates that the and alternate setback will prevent damage to the structural integrity of the CCR unit.

5.1 Description of Regional Geologic Structural Features

The Parkersburg Syncline is the predominant regional structural feature in the vicinity of the Site. The axis of the syncline is located approximately 11 miles east-southeast of the Site and it trends northeastward. Regionally, bedrock dips gently to the east-southeast towards the axis of the syncline. Locally, however, bedrock dip is essentially flat lying and is affected by isolated anticlines and mild up-warping of the bedrock strata (EPRI, 1999).

5.2 Compliance with Fault Area Restrictions

A review of available geologic reports and maps has indicated that the Site is not located near any faults with displacement in the Holocene. **Figure 8** presents a map depicting known faults in the region, all of Paleozoic age (USGS, 2005; WVGES, 2013). As shown on the figure, the nearest faults that do exist are at least tens of miles from the site. Therefore, the CCR units at this Site meet the location restriction for faults.

6. SEISMIC IMPACT ZONE

CCR Rule 40 CFR Part 257.63 requires that existing and new CCR surface impoundments must not be located within a seismic impact zone unless the owner or operator demonstrates that all structural components of the CCR unit are designed to withstand the maximum horizontal acceleration in lithified earth material for the Site.

6.1 Definition of Seismic Impact Zone

CCR Rule 40 CFR Part 257.53 defines a seismic impact zone as an area having a 2% or greater probability that the maximum horizontal acceleration expressed as a percentage of the earth's gravitational pull (g) will exceed 0.10 g in 50 years.

6.2 Compliance with Seismic Impact Zone Restriction

Figure 9 presents the map of the peak ground acceleration with a 2% probability of exceedance in 50 years for West Virginia, as published by the United States Geological Survey (USGS) Earthquake Hazards Program (USGS, 2014). As shown on **Figure 9**, the Site falls within the zone having a maximum horizontal acceleration of 0.06 to 0.1 g. Therefore, the CCR unit meets the location restriction for seismic impact zone.

7. UNSTABLE AREAS

CCR Rule 40 CFR Part 257.64 requires that existing and new CCR surface impoundments must not be located within an unstable area unless the owner or operator demonstrates that the design of the unit will ensure the integrity of the structural components of the unit.

7.1 Definition of Unstable Area and local Conditions

7.1.1 CCR Rule Definition

CCR Rule 40 CFR Part 257.53 defines an unstable area as a location that is susceptible to natural or human-induced events or forces capable of impairing the integrity of the CCR unit. These may include poor foundation conditions, areas susceptible to mass movements (landslides), and karst terrains.

7.1.2 Poor Foundation Soils

An initial geotechnical investigation of the Little Broad Run valley was conducted in 1979 prior to construction of the CCR unit. This report classified foundation soils as clay or silty clay with relatively low plasticity. Weathered sandstone and clayshale fragments. There were no poor foundation soils identified in this initial investigation (AEP, 1978).

7.1.3 Mass Movements

Figure 10 presents a map of known landslide activity in the area (USGS, 1978). While this figure indicates some areas of the landfill may be susceptible to landslides, these susceptible areas are limited in spatial extent and exist only in thin valleys at higher elevations. The majority of the CCR unit is located in the larger Little Broad Run valley, which is not susceptible to landslides. Therefore, the FGD landfill meets the siting criteria for mass movements.

7.1.4 Karst

Figure 11 presents a map of known karst features in West Virginia (WVGES, 1968). As shown on this figure, the landfill is not located in a karst area.

7.1.5 Subsurface Mining

In addition to groundwater monitoring and site characterization investigations, an evaluation of stability related to underground mining at the Philip Sporn Mine was performed in 1992 (Gales, 1992). As part of this investigation, one test hole was drilled to intercept the Pittsburg Coal seam. Samples of the coal and surrounding rock strata were collected and analyzed for mechanical properties. Additionally, pillar load calculations were performed to assess pillar strength under post-landfill construction conditions. This investigation concluded that subsidence has not occurred at the LBR Landfill, that the pillars would not fail

under increased loading, and that no sensible strain would be present at the ground surface as a result of previous mining (Gales, 1992).

7.2 Compliance with Unstable Areas Restriction

Based on the Site visit and review of available information, the landfill is not located within unstable areas. Therefore, this CCR unit meets the location restriction requirements for unstable areas.

8. SUMMARY, CONCLUSIONS, AND PE CERTIFICATION

I, John W. Holm, certify that this report was prepared under my direction and supervision, and that the information contained herein is true and accurate to the best of my knowledge. Based on my experience and knowledge of the Site, as well as the evaluations discussed within this report, the Mountaineer LBR Landfill meets the CCR surface impoundment location restrictions of 40 CFR Part 257 for separation from the uppermost aquifer, wetlands, fault areas, seismic impact zones, and unstable areas.

John W Holm

Printed Name of Registered Professional Engineer

Signature

17419

Registration No.

Registration State

Date

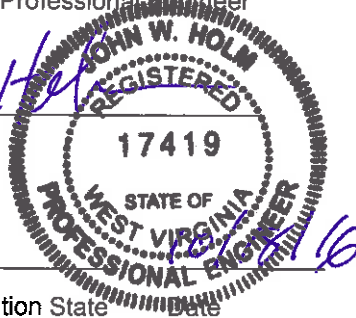

9. REFERENCES

- American Electric Power Service Corporation. 1978. Geotechnical Investigation of Little Broad Run Valley, New Haven, West Virginia.
- American Electric Power Service Corporation. 1986. Ground-Water Monitoring of Little Broad Run Valley, New Haven, West Virginia.
- American Electric Power. 1997. Class F Industrial Landfill Facility Application. Little Broad Run Landfill Disposal Site. Solid Waste/NPDES Permit Reissue Application Number WV0077038.
- American Electric Power. 1998. Class F Industrial Landfill Facility Application. Little Broad Run Landfill. Solid Waste/NPDES Permit No. WV0077038. Application for Permit Renewal – Addendum No. 1.
- American Electric Power. 2003. Solid Waste/NPDES Permit No. WV0077038, Permit Renewal Application, Little Broad Run Landfill.
- Appalachian Power Company. 1984. Application for Landfill Permit, West Virginia Department of Natural Resources – Number I-1588-L, Little Broad Run Landfill, New Haven, West Virginia.
- Appalachian Power Company. 1989. Class F Industrial Landfill Facility Application Addendum, Application Number WV0077038.
- Appalachian Power Company. 1991. Initial Supplement to WVDNR Request for Additional Information Date August 28, 1990, Application Number WV0077038.
- Banks Environmental Data, Inc. 2014. Water Well Report, AEP Water Well Inventory, Mountaineer Plant, ES-112028.
- Electric Power Research Institute (EPRI). 1999. Groundwater Quality at the Phillip Sporn and Mountaineer Power Plants, Mason County, West Virginia, Prepared for American Electric Power Service Corp.
- Fetter, Charles Willard, and C. W. Fetter. 2001. Applied hydrogeology. Vol. 3. No. 3. Upper Saddle River: Prentice Hall.
- Gales Engineering Company. 1992. Little Broad Run Landfill Mining Subsidence Evaluation, Mason County, West Virginia. Prepared for Mountaineer Plant, Sporn Plant, Appalachian Power Company.
- GAI Consultants, 2005. Report of Findings, Evaluation of the Impacts of Mining, New Haven, West Virginia, October 20, 2005.
- Hull & Associates, Inc. 2008. Vertical Expansion Engineering Design Report, Appalachian Power Company, Mountaineer Plant.
- Hull & Associates, Inc. 2010. Leachate Collection Pond and Conveyance System Engineering Design Report, Appalachian Power Company, Mountaineer Plant.
- Southeast Regional Climate Center. 2015. Historical Climate Summaries, Winfield Locks, West Virginia, <http://www.sercc.com>, Query conducted by Mr. Josh Roberts of Arcadis on October 6, 2015.

LITTLE BROAD RUN LANDFILL-CCR LOCATION RESTRICTION EVALUATION

United States Geological Survey (USGS). 1978. Landslides and Related Features of the New Haven, W. Va.-Ohio Quadrangle. Open File Map 83-80 (N-1).

United States Geological Survey (USGS). 1981. Water-Supply Paper 2177, Hydrologic Effects of Stress-Relief Fracturing in an Appalachian Valley.

United States Geological Survey (USGS). 2005. Preliminary integrated Geologic Map Databases for the United States: Kentucky, Ohio, Tennessee, and West Virginia.
<http://mrddata.usgs.gov/geology/state/state.php?state=WV>

United States Geological Survey (USGS). 2014. Seismic-Hazard Maps for the Conterminous United States. <http://earthquake.usgs.gov/hazards/products/conterminous/>

United States Geological Survey (USGS), Aquifers and Groundwater. 2015. Available online at www.usgs.gov.

West Virginia Geological and Economic Survey (WVGES). 1968. Karst regions derived from 1968 geological map of West Virginia. <http://wvgis.wvu.edu/data/dataset.php?ID=133>

West Virginia Geological and Economic Survey (WVGES). 2013. West Virginia Faults.
<https://catalog.data.gov/dataset/west-virginia-faults>

TABLE



Table 1
Water Level Data
AEP Mountaineer Generating Plant - Little Broad Run Landfill
New Haven, West Virginia

Well ID	Aug-93	Oct-93	Feb-94	Apr-94	Jul-94	Oct-94	Dec-94	Jan-95	Apr-95	Jul-95	Oct-95	Jan-96	Apr-96	Jul-96	Oct-96	Jan-97	Apr-97	Jul-97	Oct-97	Jan-98	Apr-98	Jul-98	Oct-98	
	GW Elev. ft. amsl	GW Elev. ft. amsl	GW Elev. ft. amsl	GW Elev. ft. amsl	GW Elev. ft. amsl	GW Elev. ft. amsl	GW Elev. ft. amsl	GW Elev. ft. amsl	GW Elev. ft. amsl	GW Elev. ft. amsl	GW Elev. ft. amsl	GW Elev. ft. amsl	GW Elev. ft. amsl	GW Elev. ft. amsl	GW Elev. ft. amsl	GW Elev. ft. amsl	GW Elev. ft. amsl	GW Elev. ft. amsl	GW Elev. ft. amsl	GW Elev. ft. amsl	GW Elev. ft. amsl	GW Elev. ft. amsl	GW Elev. ft. amsl	
Groundwater Quality Monitoring Wells																								
Alluvium																								
Downgradient																								
MW-38	NA	NA	NA	NA	NA	NA	NA	NA	NA	NA	NA	NA	NA	NA	NA	NA	NA	NA	NA	NA	NA	NA	NA	NA
Hydrologic Unit 3																								
Upgradient																								
MW-30	NA	NA	NA	NA	NA	NA	NA	NA	NA	NA	NA	NA	NA	NA	NA	NA	695.29	693.72	697.14	698.29	698.79	698.68	697.95	
MW-1612	NA	NA	NA	NA	NA	NA	NA	NA	NA	NA	NA	NA	NA	NA	NA	NA	NA	NA	NA	NA	NA	NA	NA	NA
Downgradient																								
MW-26	NA	NA	NA	NA	NA	NA	NA	NA	NA	NA	NA	NA	NA	NA	NA	NA	NA	NA	NA	NA	NA	NA	NA	NA
Hydrologic Unit 4																								
Downgradient																								
MW-27	NA	NA	NA	NA	NA	NA	NA	NA	NA	NA	NA	NA	NA	NA	NA	NA	646.94	646.54	645.95	645.91	646.81	647.14	NA	NA
MW-39	NA	NA	NA	NA	NA	NA	NA	NA	NA	NA	NA	NA	NA	NA	NA	NA	NA	NA	NA	NA	NA	NA	NA	NA
MW-1611	NA	NA	NA	NA	NA	NA	NA	NA	NA	NA	NA	NA	NA	NA	NA	NA	NA	NA	NA	NA	NA	NA	NA	NA
Hydraulic Monitoring Wells Only																								
Hydrologic Unit 3																								
MW-2	657.55	653.25	655.01	654.75	657.05	653.15	653.35	653.65	653.05	655.83	654.65	657.87	655.25	654.93	653.20	656.31	654.58	656.95	654.4	657.47	659.04	660.81	662.8	
MW-12	714.61	713.33	716.30	717.61	718.04	717.58	716.92	712.85	718.50	718.21	717.95	719.38	718.75	718.93	693.67	719.30	719.72	719.51	718.77	719.65	720.42	719.72	719.12	
MW-34	NA	NA	NA	NA	NA	NA	NA	NA	NA	NA	NA	NA	NA	NA	NA	NA	NA	NA	NA	NA	NA	NA	NA	NA
MW-37	NA	NA	NA	NA	NA	NA	NA	NA	NA	NA	NA	NA	NA	NA	NA	NA	NA	NA	NA	NA	NA	NA	NA	NA
Hydrologic Unit 4																								
MW-23	NA	NA	NA	NA	NA	NA	NA	NA	NA	NA	NA	NA	NA	NA	NA	NA	583.91	586.07	587.66	589.61	581.83	593.74	595.8	
MW-25	NA	NA	NA	NA	NA	NA	NA	NA	NA	NA	NA	NA	NA	NA	NA	NA	NA	NA	NA	NA	NA	NA	NA	NA
Other and Abandoned Wells																								
Alluvium																								
MW-16	618.88	618.22	620.95	621.11	620.39	619.13	620.48	621.03	620.92	619.36	619.08	621.14	620.88	620.53	620.86	621.18	620.78	619.46	618.66	620.82	621.06	621.08	617.58	
MW-17	615.58	614.14	615.52	617.49	616.88	615.06	616.70	618.09	616.43	616.19	616.29	617.02	617.42	616.52	617.53	617.57	617.29	615.84	615.22	617.67	617.33	617.91	613.85	
MW-18	614.86	614.97	615.81	617.61	616.86	615.78	617.44	617.23	616.97	615.35	615.78	617.20	617.60	617.39	617.58	617.74	617.48	616.02	615.43	617.04	617.64	617.97	614.13	
MW-19	642.14	642.14	643.33	644.34	643.71	642.75	644.14	644.64	644.39	643.02	643.54	645.14	645.14	644.23	644.11	644.04	644.24	644.24	643.84	645.14	645.14	645.14	643.34	
MW-43	NA	NA	NA	NA	NA	NA	NA	NA	NA	NA	NA	NA	NA	NA	NA	NA	NA	NA	NA	NA	NA	NA	NA	NA
MW-44s	NA	NA	NA	NA	NA	NA	NA	NA	NA	NA	NA	NA	NA	NA	NA	NA	NA	NA	NA	NA	NA	NA	NA	NA
MW-44i	NA	NA	NA	NA	NA	NA	NA	NA	NA	NA	NA	NA	NA	NA	NA	NA	NA	NA	NA	NA	NA	NA	NA	NA
MW-44d	NA	NA	NA	NA	NA	NA	NA	NA	NA	NA	NA	NA	NA	NA	NA	NA	NA	NA	NA	NA	NA	NA	NA	NA
Hydrologic Unit 1																								
MW-1	717.35	710.10	712.23	710.50	710.90	710.45	709.85	709.70	709.55	710.47	710.15	711.25	709.47	709.82	709.90	712.09	709.58	709.78	709.64	711.4	713.32	715.01	716.97	
MW-3	752.75	752.64	753.22	753.41	752.93	752.62	752.84	752.61	753.36	752.92	752.76	753.42	753.60	752.90	752.81	753.43	753.58	753.39	752.93	753.34	753.61	753.26	752.9	
MW-4	721.42	721.14	722.04	721.84	722.17	722.49	722.99	723.04	722.68	724.21	724.74	725.52	725.44	725.46	725.65	726.04	726.54	726.88	726.95	727.04	727.97	728.11	727.85	
MW-5	760.24	760.00	760.13	761.95	760.25	759.45	759.45	759.30	760.19	760.30	760.15	756.95	760.77	760.78	760.25	760.41	761.18	761.06	760.45	759.51	760.73	760.78	760.17	
MW-7	759.43	759.60	761.12	762.02	759.49	759.51	759.60	759.77	760.87	759.72	759.62	760.39	761.07	760.45	749.57	754.97	755.12	753.88	753.6	753.68	781.88	754.97	NA	
MW-10	724.50	724.47	724.25	724.27	724.01	724.60	724.07	723.67	724.25	723.67	723.71	724.40	724.27	724.33	724.29	724.82	724.37	723.69	724.57	723.65	724.04	724.29	724.34	
MW-24	NA	NA	NA	NA	NA	NA	NA	NA	NA	NA	NA	NA	NA	NA	NA	NA	NA	NA	NA	NA	NA	NA	NA	NA
MW-28	NA	NA	NA	NA	NA	NA	NA	NA	NA	NA	NA	NA	NA	NA	NA	NA	790.06	795.11	797.31	798.26	792.45	792.17	NA	
MW-29	NA	NA	NA	NA	NA	NA	NA	NA	NA	NA	NA	NA	NA	NA	NA	NA	711.14	714.75	715.61	715.94	714.33	713.14	NA	
MW-31	NA	NA	NA	NA	NA	NA	NA	NA	NA	NA	NA	NA	NA	NA	NA	NA	752.41	755.85	757.27	758.01	758.99	758.97	NA	
MW-35	NA	NA	NA	NA	NA	NA	NA	NA	NA	NA	NA	NA	NA	NA	NA	NA	NA	NA	NA	NA	NA	NA	NA	NA
MW-36	NA	NA	NA	NA	NA	NA	NA	NA	NA	NA	NA	NA	NA	NA	NA	NA	NA	NA	NA	NA	NA	NA	NA	NA
MW-45	NA	NA	NA	NA	NA	NA	NA	NA	NA	NA	NA	NA	NA	NA	NA	NA	NA	NA	NA	NA	NA	NA	NA	NA
MW-46	NA	NA	NA	NA	NA	NA	NA	NA	NA	NA	NA	NA	NA	NA	NA	NA	NA	NA	NA	NA	NA	NA	NA	NA
MW-47	NA	NA	NA	NA	NA	NA	NA	NA	NA	NA	NA	NA	NA	NA	NA	NA	NA	NA	NA	NA	NA	NA	NA	NA

Table 1
Water Level Data
AEP Mountaineer Generating Plant - Little Broad Run Landfill
New Haven, West Virginia

Well ID	Aug-93	Oct-93	Feb-94	Apr-94	Jul-94	Oct-94	Dec-94	Jan-95	Apr-95	Jul-95	Oct-95	Jan-96	Apr-96	Jul-96	Oct-96	Jan-97	Apr-97	Jul-97	Oct-97	Jan-98	Apr-98	Jul-98	Oct-98
	GW Elev. ft. amsl	GW Elev. ft. amsl	GW Elev. ft. amsl	GW Elev. ft. amsl	GW Elev. ft. amsl	GW Elev. ft. amsl	GW Elev. ft. amsl	GW Elev. ft. amsl	GW Elev. ft. amsl	GW Elev. ft. amsl	GW Elev. ft. amsl	GW Elev. ft. amsl	GW Elev. ft. amsl	GW Elev. ft. amsl	GW Elev. ft. amsl	GW Elev. ft. amsl	GW Elev. ft. amsl	GW Elev. ft. amsl	GW Elev. ft. amsl	GW Elev. ft. amsl	GW Elev. ft. amsl	GW Elev. ft. amsl	GW Elev. ft. amsl
Hydrologic Unit 3																							
MW-6	665.21	665.43	674.86	671.73	677.18	672.33	681.53	682.16	680.93	677.53	664.53	670.43	675.21	671.93	669.14	678.94	684.01	681.45	676.18	676.02	674.36	667.38	NA
MW-11	681.74	679.48	682.08	682.01	682.63	682.65	680.13	682.83	682.42	682.90	682.97	683.13	682.94	682.78	682.83	683.28	683.23	682.82	684.2	685.78	687.38	687.79	687.48
MW-13	674.90	669.74	674.73	671.55	673.25	671.20	667.28	664.55	671.30	672.30	671.15	666.77	672.03	672.16	673.21	673.65	673.55	676.15	674.25	673.88	674.8	672.95	674.58
MW-14	702.45	697.37	701.87	700.87	701.67	700.19	698.24	693.87	701.59	686.92	701.27	677.05	701.61	691.59	701.52	699.97	702.81	702.81	702	702.31	702.82	703.05	NA
MW-20	667.33	666.85	668.05	668.88	667.46	666.84	666.80	667.03	668.03	667.18	667.08	668.13	668.91	667.91	668.26	668.83	668.68	667.68	667.38	668.48	668.8	669.11	666.96
Hydrologic Unit 4																							
MW-8	671.43	671.43	673.28	674.09	672.33	670.61	671.19	671.97	673.03	670.98	671.03	673.65	674.54	671.86	672.38	674.34	671.81	671.23	670.55	672.73	672.39	672.99	670.53
MW-9	634.15	633.90	635.58	635.90	634.35	633.72	634.18	634.73	635.38	634.07	633.80	635.37	635.64	634.51	635.10	635.65	635.55	634.2	633.71	634.75	635.53	634.99	632.92
MW-15	671.28	671.52	673.22	674.00	672.20	670.75	671.57	672.20	673.25	671.00	670.95	673.56	674.62	671.84	672.39	673.85	671.84	671.46	670.57	671.5	672.42	673.49	670.45
MW-21	NA	NA	NA	NA	NA	NA	NA	NA	NA	NA	NA	NA	NA	NA	NA	NA	655.03	653.1	653.04	654.5	655.45	655.26	652.75
MW-22	NA	NA	NA	NA	NA	NA	NA	NA	NA	NA	NA	NA	NA	NA	NA	NA	647.76	686.27	689.54	694.47	694.62	694.42	691.4
MW-33	NA	NA	NA	NA	NA	NA	NA	NA	NA	NA	NA	NA	NA	NA	NA	NA	672.17	671.15	670.71	671.79	672.83	673.42	670.75
Pittsburg Sandstone																							
MW-40	NA	NA	NA	NA	NA	NA	NA	NA	NA	NA	NA	NA	NA	NA	NA	NA	NA	NA	NA	NA	NA	NA	NA
Redstone Coal																							
MW-41	NA	NA	NA	NA	NA	NA	NA	NA	NA	NA	NA	NA	NA	NA	NA	NA	NA	NA	NA	NA	NA	NA	NA
MW-42	NA	NA	NA	NA	NA	NA	NA	NA	NA	NA	NA	NA	NA	NA	NA	NA	NA	NA	NA	NA	NA	NA	NA
Pittsburg Coal																							
MW-32	NA	NA	NA	NA	NA	NA	NA	NA	NA	NA	NA	NA	NA	NA	NA	NA	516.87	517.32	517.01	517.6	519.55	520.71	NA
Piezometers																							
CTL PZ-1	NA	NA	NA	NA	NA	NA	NA	NA	NA	NA	NA	NA	NA	NA	NA	NA	NA	NA	NA	NA	NA	NA	NA
CTL PZ-4	NA	NA	NA	NA	NA	NA	NA	NA	NA	NA	NA	NA	NA	NA	NA	NA	NA	NA	NA	NA	NA	NA	NA
MW-46S	NA	NA	NA	NA	NA	NA	NA	NA	NA	NA	NA	NA	NA	NA	NA	NA	NA	NA	NA	NA	NA	NA	NA
MW-47S	NA	NA	NA	NA	NA	NA	NA	NA	NA	NA	NA	NA	NA	NA	NA	NA	NA	NA	NA	NA	NA	NA	NA
HMW-1	NA	NA	NA	NA	NA	NA	NA	NA	NA	NA	NA	NA	NA	NA	NA	NA	NA	NA	NA	NA	NA	NA	NA
HMW-2	NA	NA	NA	NA	NA	NA	NA	NA	NA	NA	NA	NA	NA	NA	NA	NA	NA	NA	NA	NA	NA	NA	NA
HMW-3	NA	NA	NA	NA	NA	NA	NA	NA	NA	NA	NA	NA	NA	NA	NA	NA	NA	NA	NA	NA	NA	NA	NA
HMW-4	NA	NA	NA	NA	NA	NA	NA	NA	NA	NA	NA	NA	NA	NA	NA	NA	NA	NA	NA	NA	NA	NA	NA
HMW-5	NA	NA	NA	NA	NA	NA	NA	NA	NA	NA	NA	NA	NA	NA	NA	NA	NA	NA	NA	NA	NA	NA	NA

Table 1
Water Level Data
AEP Mountaineer Generating Plant - Little Broad Run Landfill
New Haven, West Virginia

Well ID	Jan-99	Apr-99	Jul-99	Oct-99	Jan-00	Feb-00	Apr-00	Jul-00	Oct-00	Jan-01	Apr-01	May-01	Jul-01	Oct-01	Jan-02	Apr-02	Jul-02	Oct-02	Jan-03	Jul-05	Jul-16	Aug-16
	GW Elev. ft. amsl	GW Elev. ft. amsl	GW Elev. ft. amsl	GW Elev. ft. amsl	GW Elev. ft. amsl	GW Elev. ft. amsl	GW Elev. ft. amsl	GW Elev. ft. amsl	GW Elev. ft. amsl	GW Elev. ft. amsl	GW Elev. ft. amsl	GW Elev. ft. amsl	GW Elev. ft. amsl	GW Elev. ft. amsl	GW Elev. ft. amsl	GW Elev. ft. amsl	GW Elev. ft. amsl	GW Elev. ft. amsl	GW Elev. ft. amsl	GW Elev. ft. amsl	GW Elev. ft. amsl	GW Elev. ft. amsl
Groundwater Quality Monitoring Wells																						
Alluvium																						
Downgradient																						
MW-38	NA	NA	NA	NA	NA	NA	NA	NA	NA	NA	NA	NA	NA	NA	NA	NA	NA	NA	NA	623.49	NA	NA
Hydrologic Unit 3																						
Upgradient																						
MW-30	NA	697.45	NA	698.12	NA	NA	698.02	NA	698.07	NA	699.33	NA	NA	698.4	NA	698.7	NA	698.34	NA	700.85	NA	NA
MW-1612	NA	NA	NA	NA	NA	NA	NA	NA	NA	NA	NA	NA	NA	NA	NA	NA	NA	NA	NA	NA	NA	737.34
Downgradient																						
MW-26	NA	NA	NA	NA	NA	NA	NA	NA	NA	NA	NA	NA	NA	NA	NA	NA	NA	NA	NA	669.80	NA	NA
Hydrologic Unit 4																						
Downgradient																						
MW-27	NA	NA	NA	NA	NA	NA	NA	NA	NA	NA	NA	NA	NA	NA	NA	NA	NA	NA	NA	647.39	NA	NA
MW-39	NA	NA	NA	NA	NA	NA	NA	NA	NA	NA	NA	NA	NA	NA	NA	NA	NA	NA	NA	623.20	NA	NA
MW-1611	NA	NA	NA	NA	NA	NA	NA	NA	NA	NA	NA	NA	NA	NA	NA	NA	NA	NA	NA	NA	642.80	NA
Hydraulic Monitoring Wells Only																						
Hydrologic Unit 3																						
MW-2	674.46	664.94	667.47	668.14	669.88	NA	670.68	672.1	676.42	673.1	674.63	NA	675.2	676	681.59	676.47	677.18	NA	NA	689.75	NA	NA
MW-12	720.9	720.8	720.23	720.26	721.85	NA	722.76	722.12	721.86	719.5	719.17	NA	719.97	718.04	717.59	718.04	718.92	721.32	NA	723.83	NA	NA
MW-34	NA	NA	NA	NA	NA	NA	NA	NA	NA	NA	NA	NA	NA	NA	NA	NA	NA	NA	NA	NA	673.88	NA
MW-37	NA	NA	NA	NA	NA	NA	NA	NA	NA	NA	NA	NA	NA	NA	NA	NA	NA	NA	NA	687.03	NA	NA
Hydrologic Unit 4																						
MW-23	NA	601.23	604.81	NA	NA	NA	618.34	621.03	NA	NA	627.58	NA	NA	629.91	NA	NA	631.75	NA	NA	NA	NA	NA
MW-25	NA	NA	NA	NA	NA	NA	NA	NA	NA	NA	NA	NA	NA	NA	NA	NA	NA	NA	NA	NA	NA	NA
Other and Abandoned Wells																						
Alluvium																						
MW-16	NA	620.94	NA	620.18	NA	NA	621.31	NA	619.42	NA	621.32	NA	NA	617.96	NA	620.93	NA	619.20	NA	618.78	NA	NA
MW-17	NA	617.29	NA	616.27	NA	NA	617.99	NA	616.65	NA	617.5	NA	NA	615.17	NA	617.86	NA	616.59	NA	616.11	NA	NA
MW-18	NA	617.19	NA	615.91	NA	NA	618.05	NA	616.35	NA	617.78	NA	NA	615.57	NA	617.83	NA	616.63	NA	615.62	NA	NA
MW-19	NA	645.14	NA	644.52	NA	NA	645.14	NA	644.17	NA	645.14	NA	NA	643.59	NA	645.14	NA	643.89	NA	NA	NA	NA
MW-43	NA	NA	NA	NA	NA	NA	NA	NA	NA	NA	NA	NA	NA	NA	NA	NA	NA	NA	NA	630.15	NA	NA
MW-44s	NA	NA	NA	NA	NA	NA	NA	NA	NA	NA	NA	NA	NA	NA	NA	NA	NA	NA	NA	617.43	NA	NA
MW-44i	NA	NA	NA	NA	NA	NA	NA	NA	NA	NA	NA	NA	NA	NA	NA	NA	NA	NA	NA	616.79	NA	NA
MW-44d	NA	NA	NA	NA	NA	NA	NA	NA	NA	NA	NA	NA	NA	NA	NA	NA	NA	NA	NA	617.04	NA	NA
Hydrologic Unit 1																						
MW-1	718.48	719.35	720.82	721.95	723.19	NA	724.12	725.13	725.82	727.15	728.24	NA	729.03	730.03	730.76	731.51	732.2	NA	NA	746.95	NA	NA
MW-3	NA	753.55	NA	752.69	NA	NA	752.69	NA	752.64	NA	753.14	NA	NA	752.71	NA	752.36	NA	752.76	NA	753.06	NA	NA
MW-4	728.07	728.4	725.74	724.93	NA	724.93	724.18	723.99	723.99	723.9	723.79	NA	723.65	723.71	724.44	723.49	722.77	722.48	NA	NA	NA	NA
MW-5	760.07	760.11	760.32	759.86	760.1	NA	760.45	760.33	760.16	759.53	760.23	NA	760.06	759.75	759.23	759.47	759.68	759.41	760.01	758.90	NA	NA
MW-7	NA	NA	NA	NA	NA	NA	NA	NA	NA	NA	NA	NA	NA	NA	NA	NA	NA	NA	NA	NA	NA	NA
MW-10	NA	724.34	724.33	724.11	725.57	NA	724.65	723.89	NA	724.62	724.59	NA	724.45	724.57	724.07	724.3	723.49	723.77	NA	NA	NA	NA
MW-24	NA	NA	NA	NA	NA	NA	NA	NA	NA	NA	NA	NA	NA	NA	NA	NA	NA	NA	NA	737.76	NA	NA
MW-28	NA	NA	NA	NA	NA	NA	NA	NA	NA	NA	NA	NA	NA	NA	NA	NA	NA	NA	NA	808.73	NA	NA
MW-29	NA	NA	NA	NA	NA	NA	NA	NA	NA	NA	NA	NA	NA	NA	NA	NA	NA	NA	NA	748.73	NA	NA
MW-31	NA	NA	NA	NA	NA	NA	NA	NA	NA	NA	NA	NA	NA	NA	NA	NA	NA	NA	NA	762.56	NA	NA
MW-35	NA	NA	NA	NA	NA	NA	NA	NA	NA	NA	NA	NA	NA	NA	NA	NA	NA	NA	NA	728.15	NA	NA
MW-36	NA	NA	NA	NA	NA	NA	NA	NA	NA	NA	NA	NA	NA	NA	NA	NA	NA	NA	NA	731.05	NA	NA
MW-45	NA	NA	NA	NA	NA	NA	NA	NA	NA	NA	NA	NA	NA	NA	NA	NA	NA	NA	NA	750.28	NA	NA
MW-46	NA	NA	NA	NA	NA	NA	NA	NA	NA	NA	NA	NA	NA	NA	NA	NA	NA	NA	NA	775.68	NA	NA
MW-47	NA	NA	NA	NA	NA	NA	NA	NA	NA	NA	NA	NA	NA	NA	NA	NA	NA	NA	NA	766.39	NA	NA

Table 1
Water Level Data
AEP Mountaineer Generating Plant - Little Broad Run Landfill
New Haven, West Virginia

Well ID	Jan-99	Apr-99	Jul-99	Oct-99	Jan-00	Feb-00	Apr-00	Jul-00	Oct-00	Jan-01	Apr-01	May-01	Jul-01	Oct-01	Jan-02	Apr-02	Jul-02	Oct-02	Jan-03	Jul-05	Jul-16	Aug-16
	GW Elev. ft. amsl	GW Elev. ft. amsl	GW Elev. ft. amsl	GW Elev. ft. amsl	GW Elev. ft. amsl	GW Elev. ft. amsl	GW Elev. ft. amsl	GW Elev. ft. amsl	GW Elev. ft. amsl	GW Elev. ft. amsl	GW Elev. ft. amsl	GW Elev. ft. amsl	GW Elev. ft. amsl	GW Elev. ft. amsl	GW Elev. ft. amsl	GW Elev. ft. amsl	GW Elev. ft. amsl	GW Elev. ft. amsl	GW Elev. ft. amsl	GW Elev. ft. amsl	GW Elev. ft. amsl	GW Elev. ft. amsl
Hydrologic Unit 3																						
MW-6	NA	NA	NA	NA	NA	NA	NA	NA	NA	NA	NA	NA	NA	NA	NA	NA	NA	NA	NA	NA	NA	NA
MW-11	NA	687.45	687.43	686	686.32	NA	686.45	686.31	NA	685.61	685.74	NA	685.63	685.62	685.55	685.8	686.05	684.51	NA	NA	NA	NA
MW-13	679.44	680.46	680.52	680.7	681.3	NA	681.43	680.82	680.73	681.05	681.3	NA	680.92	680.95	680.97	680.88	680.55	680.45	NA	NA	NA	NA
MW-14	NA	NA	NA	NA	NA	NA	NA	NA	NA	NA	NA	NA	NA	NA	NA	NA	NA	NA	NA	NA	NA	NA
MW-20	NA	668.37	NA	668.18	NA	NA	669.28	NA	667.35	NA	668.65	NA	NA	667.03	NA	668.1	NA	667.27	NA	NA	NA	NA
Hydrologic Unit 4																						
MW-8	NA	671.73	NA	671.58	NA	NA	671.66	NA	670.67	NA	670.9	NA	NA	669.66	NA	670.9	NA	670.28	NA	NA	NA	NA
MW-9	NA	635.12	NA	633.12	NA	NA	635.66	NA	633.98	NA	635.16	NA	NA	633.09	NA	634.95	NA	633.63	NA	NA	NA	NA
MW-15	671.96	671.78	671	670.39	NA	670.39	671.67	671.67	670.64	670.2	670.91	NA	670.56	669.73	670.22	671.42	670.85	670.54	NA	NA	NA	NA
MW-21	NA	654.66	NA	653.7	NA	NA	655.18	NA	653.62	NA	654.78	NA	NA	652.9	NA	654.36	NA	652.95	NA	NA	NA	NA
MW-22	NA	685.91	NA	695.89	NA	NA	695.75	NA	694.78	NA	694.65	NA	NA	693.75	NA	690.94	NA	692.91	NA	NA	NA	NA
MW-33	NA	NA	671.01	671.83	NA	NA	671.99	NA	670.5	NA	NA	670.39	NA	669.8	NA	671.02	NA	671.23	NA	NA	NA	NA
Pittsburg Sandstone																						
MW-40	NA	NA	NA	NA	NA	NA	NA	NA	NA	NA	NA	NA	NA	NA	NA	NA	NA	NA	NA	504.16	NA	NA
Redstone Coal																						
MW-41	NA	NA	NA	NA	NA	NA	NA	NA	NA	NA	NA	NA	NA	NA	NA	NA	NA	NA	NA	NA	NA	NA
MW-42	NA	NA	NA	NA	NA	NA	NA	NA	NA	NA	NA	NA	NA	NA	NA	NA	NA	NA	NA	622.57	NA	NA
Pittsburg Coal																						
MW-32	NA	NA	NA	NA	NA	NA	NA	NA	NA	NA	NA	NA	NA	NA	NA	NA	NA	NA	NA	NA	NA	NA
Piezometers																						
CTL PZ-1	NA	NA	NA	NA	NA	NA	NA	NA	NA	NA	NA	NA	NA	NA	NA	NA	NA	NA	NA	774.05	NA	NA
CTL PZ-4	NA	NA	NA	NA	NA	NA	NA	NA	NA	NA	NA	NA	NA	NA	NA	NA	NA	NA	NA	791.14	NA	NA
MW-46S	NA	NA	NA	NA	NA	NA	NA	NA	NA	NA	NA	NA	NA	NA	NA	NA	NA	NA	NA	803.73	NA	NA
MW-47S	NA	NA	NA	NA	NA	NA	NA	NA	NA	NA	NA	NA	NA	NA	NA	NA	NA	NA	NA	789.55	NA	NA
HMW-1	NA	NA	NA	NA	NA	NA	NA	NA	NA	NA	NA	NA	NA	NA	NA	NA	NA	NA	NA	723.07	NA	NA
HMW-2	NA	NA	NA	NA	NA	NA	NA	NA	NA	NA	NA	NA	NA	NA	NA	NA	NA	NA	NA	796.19	NA	NA
HMW-3	NA	NA	NA	NA	NA	NA	NA	NA	NA	NA	NA	NA	NA	NA	NA	NA	NA	NA	NA	799.06	NA	NA
HMW-4	NA	NA	NA	NA	NA	NA	NA	NA	NA	NA	NA	NA	NA	NA	NA	NA	NA	NA	NA	785.35	NA	NA
HMW-5	NA	NA	NA	NA	NA	NA	NA	NA	NA	NA	NA	NA	NA	NA	NA	NA	NA	NA	NA	814.86	NA	NA

Notes:

Shaded - well not verified or abandoned
 Elevation in feet above mean sea level
 amsl - above mean sea level
 Elev - elevation
 ft - feet
 GW - groundwater
 NA - Not available

FIGURES



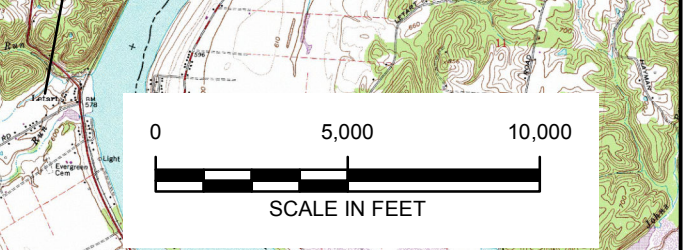

AEP MOUNTAINEER GENERATING PLANT - LBR LANDFILL
 BROAD RUN ROAD
 NEW HAVEN, WEST VIRGINIA

SITE LOCATION MAP

City: CITRIX Div/Group: MIDV Created By: K.Ives Last Saved By: webb
OH:015976.0009.00001 (Mountaineer Ash Pond)
Z:\GIS\PROJECTS_ENV\AEP\Mountaineer\MXD\Landfill Report\Updated September 2016\F2_Mir_Landfill Well Network - Plant and CCR Unit Location Map.mxd 9/16/2016 10:12:21 AM

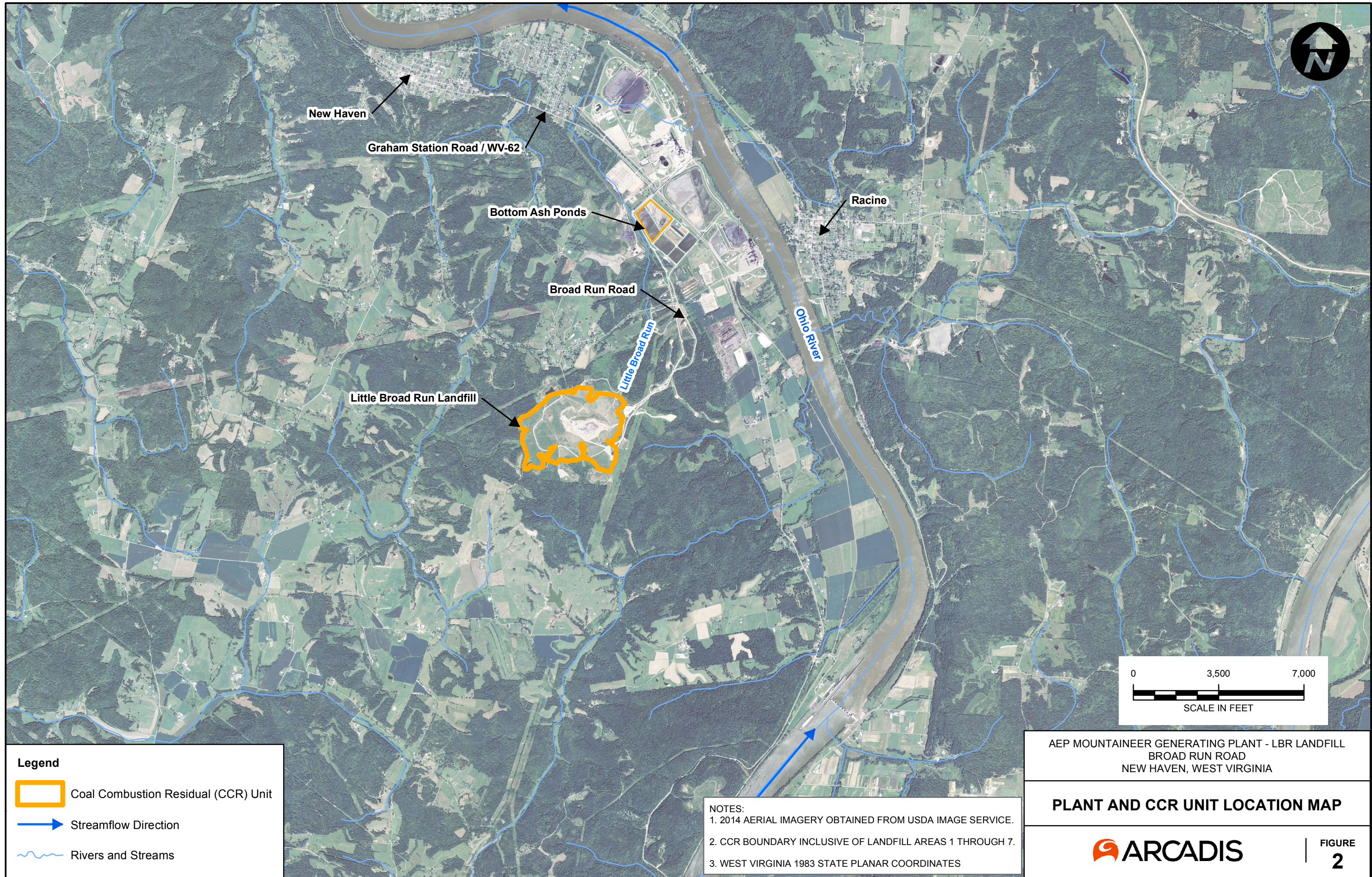

ALLUVIUM
 MW-16, MW-17, MW-18, MW-19, MW-38,
 MW-43, MW-44S, MW-44I, MW-44D
HYDROLOGIC UNIT 1
 MW-1, MW-3, MW-4, MW-5, MW-7, MW-10,
 MW-24, MW-28, MW-29, MW-31, MW-35,
 MW-36, MW-45, MW-46, MW-47
HYDROLOGIC UNIT 3
 MW-2, MW-6, MW-11, MW-12, MW-13, MW-14,
 MW-20, MW-26, MW-30, MW-34, MW-37, MW-1612
HYDROLOGIC UNIT 4
 MW-8, MW-9, MW-15, MW-21, MW-22, MW-23,
 MW-25, MW-27, MW-33, MW-39, MW-1611
PITTSBURG SANDSTONE
 MW-40
REDSTONE COAL
 MW-41, MW-42
PITTSBURG COAL
 MW-32
PIEZOMETERS
 CTL PZ-1, CTL PZ-4, MW-46S, MW-47S,
 HMMW-1, HMMW-2, HMMW-3, HMMW-4, HMMW-5

Legend

- CCR Unit Boundary
- Monitoring Well Network (gray if abandoned)**
- Alluvium
- Hydrologic Unit 1
- Hydrologic Unit 3
- Hydrologic Unit 4
- Piezometer
- Pittsburg Coal
- Pittsburg Sandstone
- Redstone Coal
- Streamflow Direction
- Rivers and Streams
- Pond Boundary
- Sporn Mine Footprint (Closed in 1975)

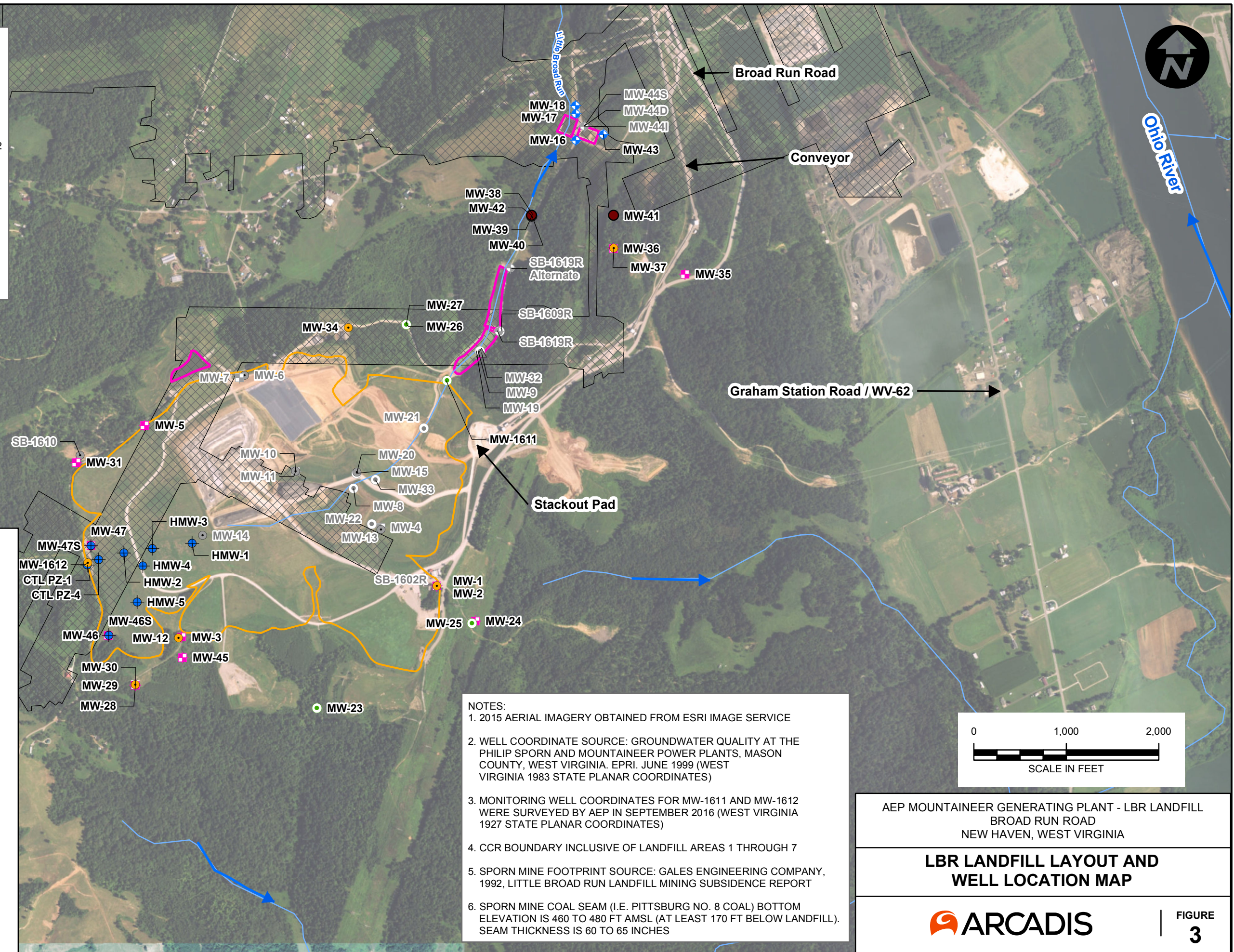

NOTES:

- 2015 AERIAL IMAGERY OBTAINED FROM ESRI IMAGE SERVICE
- WELL COORDINATE SOURCE: GROUNDWATER QUALITY AT THE PHILIP SPORN AND MOUNTAINEER POWER PLANTS, MASON COUNTY, WEST VIRGINIA. EPRI. JUNE 1999 (WEST VIRGINIA 1983 STATE PLANAR COORDINATES)
- MONITORING WELL COORDINATES FOR MW-1611 AND MW-1612 WERE SURVEYED BY AEP IN SEPTEMBER 2016 (WEST VIRGINIA 1927 STATE PLANAR COORDINATES)
- CCR BOUNDARY INCLUSIVE OF LANDFILL AREAS 1 THROUGH 7
- SPORN MINE FOOTPRINT SOURCE: GALES ENGINEERING COMPANY, 1992, LITTLE BROAD RUN LANDFILL MINING SUBSIDENCE REPORT
- SPORN MINE COAL SEAM (I.E. PITTSBURG NO. 8 COAL) BOTTOM ELEVATION IS 460 TO 480 FT AMSL (AT LEAST 170 FT BELOW LANDFILL). SEAM THICKNESS IS 60 TO 65 INCHES

AEP MOUNTAINEER GENERATING PLANT - LBR LANDFILL
 BROAD RUN ROAD
 NEW HAVEN, WEST VIRGINIA

**LBR LANDFILL LAYOUT AND
 WELL LOCATION MAP**

**FIGURE
 3**

City: CITRIX Div/Group: IM/DV Created By: K.Ives Last Saved By: webb
 OH1015976 0009.00001 (Mountaineer Ash Pond)
 Z:\GIS\PROJECTS_ENV\AEP\Mountaineer\MXD\Landfill\Report\Updated September 2016\F3_Mir_Landfill Well Network.mxd 9/19/2016 9:23:44 AM

ALLUVIUM
 MW-16, MW-17, MW-18, MW-19, MW-38,
 MW-43, MW-44S, MW-44I, MW-44D

HYDROLOGIC UNIT 1
 MW-1, MW-3, MW-4, MW-5, MW-7, MW-10,
 MW-24, MW-28, MW-29, MW-31, MW-35,
 MW-36, MW-45, MW-46, MW-47

HYDROLOGIC UNIT 3
 MW-2, MW-6, MW-11, MW-12, MW-13, MW-14,
 MW-20, MW-26, MW-30, MW-34, MW-37, MW-1612

HYDROLOGIC UNIT 4
 MW-8, MW-9, MW-15, MW-21, MW-22, MW-23,
 MW-25, MW-27, MW-33, MW-39, MW-1611

PITTSBURG SANDSTONE
 MW-40

REDSTONE COAL
 MW-41, MW-42

PITTSBURG COAL
 MW-32

PIEZOMETERS
 CTL PZ-1, CTL PZ-4, MW-46S, MW-47S,
 HMW-1, HMW-2, HMW-3, HMW-4, HMW-5

Legend

- CCR Unit Boundary
- Monitoring Well Network (gray if abandoned)**
- Alluvium
- Hydrologic Unit 1
- Hydrologic Unit 3
- Hydrologic Unit 4
- Piezometer
- Pittsburg Coal
- Pittsburg Sandstone
- Redstone Coal
- Cross Section Location
- Streamflow Direction
- Rivers and Streams
- Topographic Contour (Contour Interval - 10 feet)
- Pond Boundary

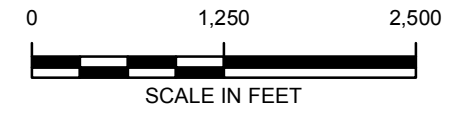
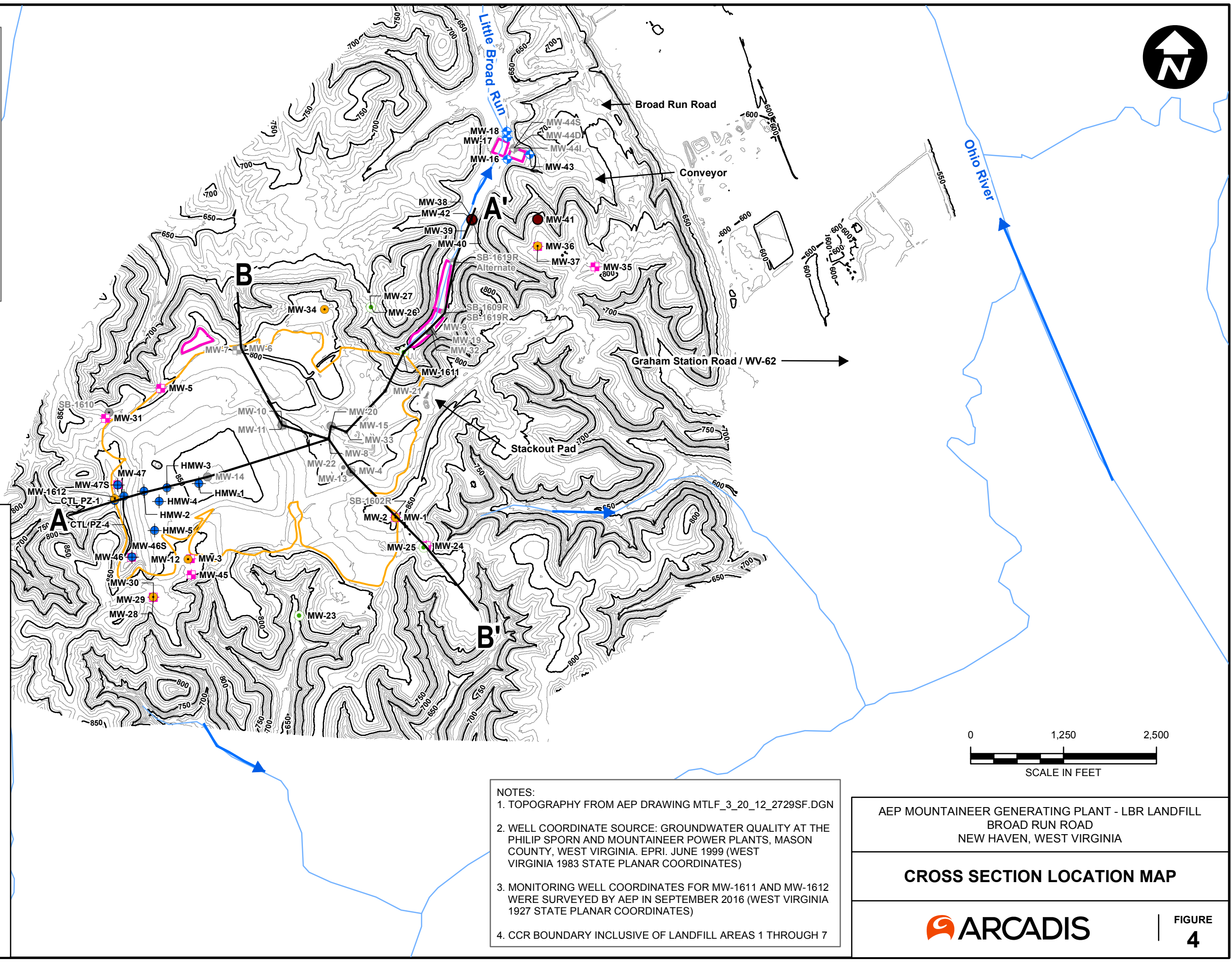

NOTES:

1. TOPOGRAPHY FROM AEP DRAWING MTLF_3_20_12_2729SF.DGN
2. WELL COORDINATE SOURCE: GROUNDWATER QUALITY AT THE PHILIP SPORN AND MOUNTAINEER POWER PLANTS, MASON COUNTY, WEST VIRGINIA. EPRI. JUNE 1999 (WEST VIRGINIA 1983 STATE PLANAR COORDINATES)
3. MONITORING WELL COORDINATES FOR MW-1611 AND MW-1612 WERE SURVEYED BY AEP IN SEPTEMBER 2016 (WEST VIRGINIA 1927 STATE PLANAR COORDINATES)
4. CCR BOUNDARY INCLUSIVE OF LANDFILL AREAS 1 THROUGH 7

AEP MOUNTAINEER GENERATING PLANT - LBR LANDFILL
 BROAD RUN ROAD
 NEW HAVEN, WEST VIRGINIA

CROSS SECTION LOCATION MAP



City: CITRIX Div/Group: IM/DV Created By: K.Ives Last Saved By: webb
 OH:015976.0009.00001 (Mountaineer Ash Pond)
 Z:\GIS\PROJECTS_ENV\AEP\Mountaineer\MXD\Landfill\Report\Updated September 2016\F4_Mtr Landfill Well Network - Cross Section Location Map_topo.mxd 9/19/2016 9:25:50 AM

G:\ENVCAD\GIS\PROJECTS\2016\2016-0003 - LANDFILL\CH01015976-MTR-LBR LANDFILL-2016-CS.dwg LAYOUT: CS-A-A SAVED: 9/22/2016 12:08 PM ACADVER: 19.15 (LMS TECH) PAGES: 10 PLOTTED: 9/22/2016 12:20 PM BY: SMITH, BOB XREFS:

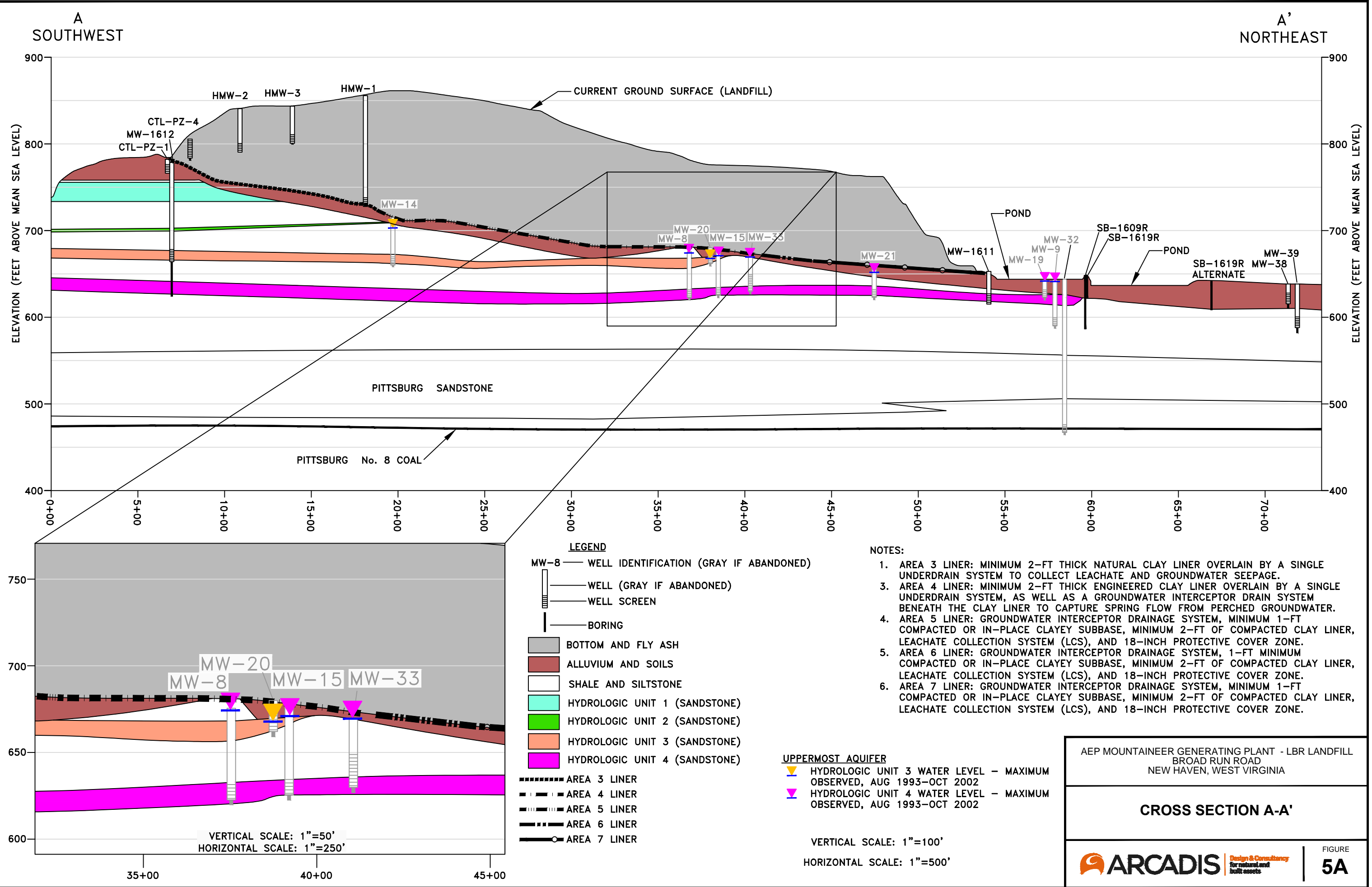

LEGEND

- MW-8 — WELL IDENTIFICATION (GRAY IF ABANDONED)
- WELL (GRAY IF ABANDONED)
- WELL SCREEN
- BORING
- BOTTOM AND FLY ASH
- ALLUVIUM AND SOILS
- SHALE AND SILTSTONE
- HYDROLOGIC UNIT 1 (SANDSTONE)
- HYDROLOGIC UNIT 2 (SANDSTONE)
- HYDROLOGIC UNIT 3 (SANDSTONE)
- HYDROLOGIC UNIT 4 (SANDSTONE)
- AREA 3 LINER
- AREA 4 LINER
- AREA 5 LINER
- AREA 6 LINER
- AREA 7 LINER

NOTES:

1. AREA 3 LINER: MINIMUM 2-FEET THICK NATURAL CLAY LINER OVERLAIN BY A SINGLE UNDERDRAIN SYSTEM TO COLLECT LEACHATE AND GROUNDWATER SEEPAGE.
3. AREA 4 LINER: MINIMUM 2-FEET THICK ENGINEERED CLAY LINER OVERLAIN BY A SINGLE UNDERDRAIN SYSTEM, AS WELL AS A GROUNDWATER INTERCEPTOR DRAIN SYSTEM BENEATH THE CLAY LINER TO CAPTURE SPRING FLOW FROM PERCHED GROUNDWATER.
4. AREA 5 LINER: GROUNDWATER INTERCEPTOR DRAINAGE SYSTEM, MINIMUM 1-FEET COMPACTED OR IN-PLACE CLAYEY SUBBASE, MINIMUM 2-FEET OF COMPACTED CLAY LINER, LEACHATE COLLECTION SYSTEM (LCS), AND 18-INCH PROTECTIVE COVER ZONE.
5. AREA 6 LINER: GROUNDWATER INTERCEPTOR DRAINAGE SYSTEM, 1-FEET MINIMUM COMPACTED OR IN-PLACE CLAYEY SUBBASE, MINIMUM 2-FEET OF COMPACTED CLAY LINER, LEACHATE COLLECTION SYSTEM (LCS), AND 18-INCH PROTECTIVE COVER ZONE.
6. AREA 7 LINER: GROUNDWATER INTERCEPTOR DRAINAGE SYSTEM, MINIMUM 1-FEET COMPACTED OR IN-PLACE CLAYEY SUBBASE, MINIMUM 2-FEET OF COMPACTED CLAY LINER, LEACHATE COLLECTION SYSTEM (LCS), AND 18-INCH PROTECTIVE COVER ZONE.

UPPERMOST AQUIFER

- ▲ HYDROLOGIC UNIT 3 WATER LEVEL - MAXIMUM OBSERVED, AUG 1993-OCT 2002
- ▲ HYDROLOGIC UNIT 4 WATER LEVEL - MAXIMUM OBSERVED, AUG 1993-OCT 2002

VERTICAL SCALE: 1"=100'
 HORIZONTAL SCALE: 1"=500'

AEP MOUNTAINEER GENERATING PLANT - LBR LANDFILL
 BROAD RUN ROAD
 NEW HAVEN, WEST VIRGINIA

CROSS SECTION A-A'

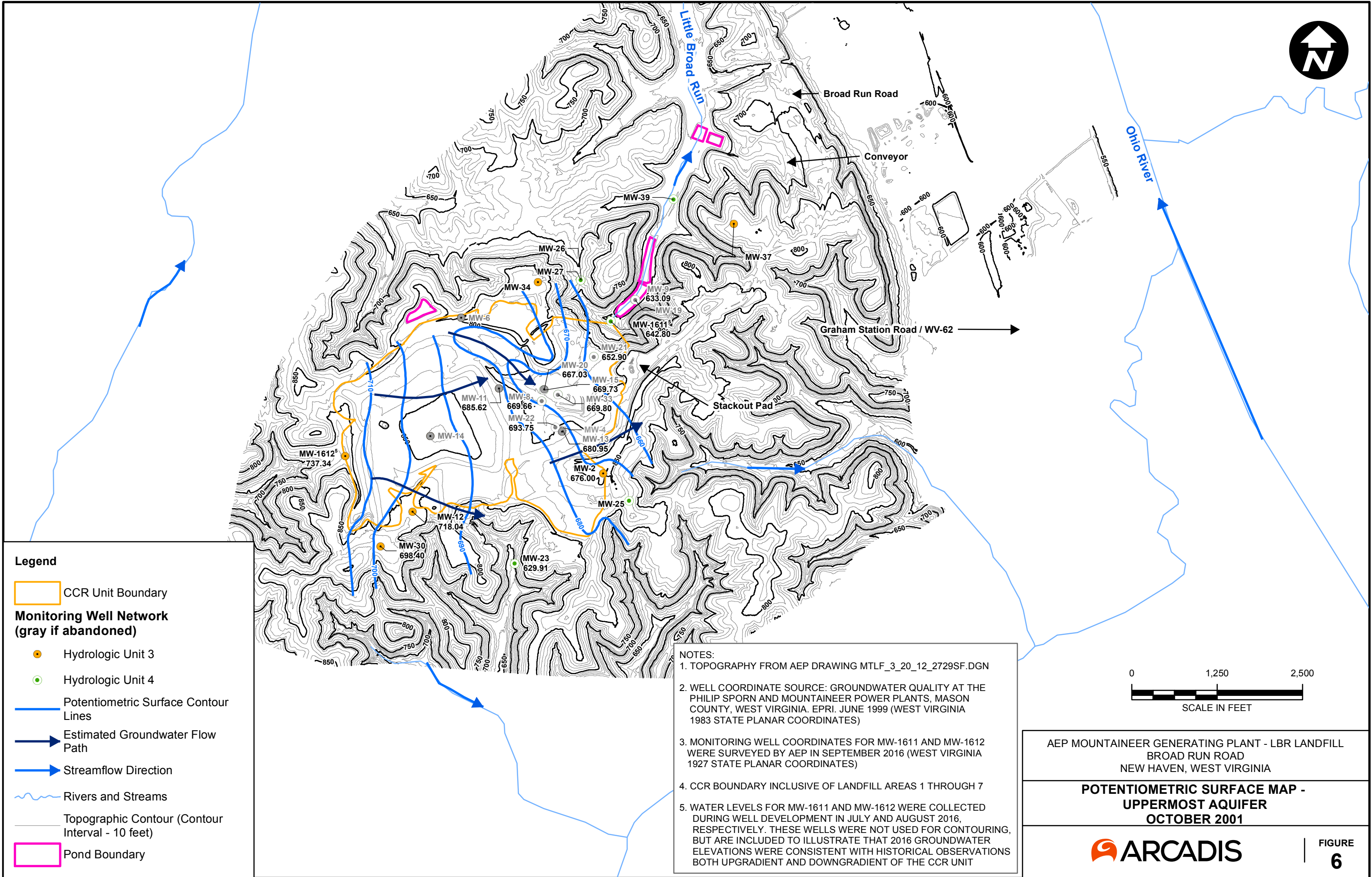

City: CITRIX Div/Group: IM/DV Created By: K.Ives Last Saved By: webb
 OH:015976.0009.00001 (Mountaineer Ash Pond)
 Z:\GIS\PROJECTS_ENV\AEP\Mountaineer\MXD\Landfill\Report\Updated September 2016\F7_Mtr_Landfill_Pond_Location_restrictions - surface water features.mxd 9/21/2016 10:23:03 AM

ALLUVIUM
 MW-16, MW-17, MW-18, MW-19, MW-38,
 MW-43, MW-44S, MW-44I, MW-44D

HYDROLOGIC UNIT 1
 MW-1, MW-3, MW-4, MW-5, MW-7, MW-10,
 MW-24, MW-28, MW-29, MW-31, MW-35,
 MW-36, MW-45, MW-46, MW-47

HYDROLOGIC UNIT 3
 MW-2, MW-6, MW-11, MW-12, MW-13, MW-14,
 MW-20, MW-26, MW-30, MW-34, MW-37, MW-1612

HYDROLOGIC UNIT 4
 MW-8, MW-9, MW-15, MW-21, MW-22, MW-23,
 MW-25, MW-27, MW-33, MW-39, MW-1611

PITTSBURG SANDSTONE
 MW-40

REDSTONE COAL
 MW-41, MW-42

PITTSBURG COAL
 MW-32

PIEZOMETERS
 CTL PZ-1, CTL PZ-4, MW-46S, MW-47S,
 HMW-1, HMW-2, HMW-3, HMW-4, HMW-5

Legend

CCR Unit Boundary

Monitoring Well Network (gray if abandoned)

- Alluvium
- Hydrologic Unit 1
- Hydrologic Unit 3
- Hydrologic Unit 4
- Piezometer
- Pittsburg Coal
- Pittsburg Sandstone
- Redstone Coal
- Streamflow Direction
- Rivers and Streams
- Pond Boundary
- Sporn Mine Footprint (Closed in 1975)

National Wetlands Inventory

- Emergent Wetland
- Pond
- Riverine
- Intermittent or Perennial Stream/River
- Ephemeral Stream/River
- Artificial Path

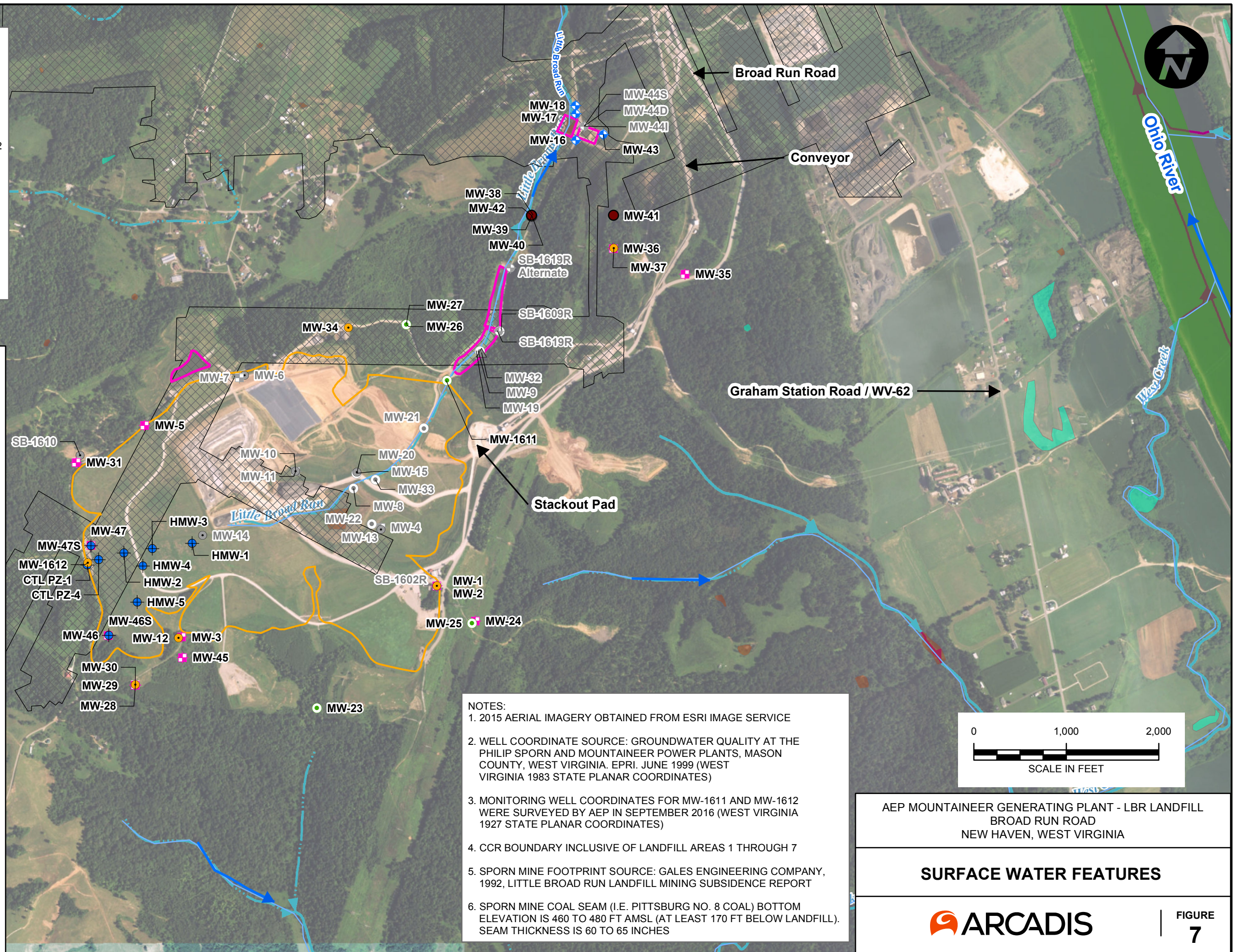

NOTES:

- 2015 AERIAL IMAGERY OBTAINED FROM ESRI IMAGE SERVICE
- WELL COORDINATE SOURCE: GROUNDWATER QUALITY AT THE PHILIP SPORN AND MOUNTAINEER POWER PLANTS, MASON COUNTY, WEST VIRGINIA. EPRI. JUNE 1999 (WEST VIRGINIA 1983 STATE PLANAR COORDINATES)
- MONITORING WELL COORDINATES FOR MW-1611 AND MW-1612 WERE SURVEYED BY AEP IN SEPTEMBER 2016 (WEST VIRGINIA 1927 STATE PLANAR COORDINATES)
- CCR BOUNDARY INCLUSIVE OF LANDFILL AREAS 1 THROUGH 7
- SPORN MINE FOOTPRINT SOURCE: GALES ENGINEERING COMPANY, 1992, LITTLE BROAD RUN LANDFILL MINING SUBSIDENCE REPORT
- SPORN MINE COAL SEAM (I.E. PITTSBURG NO. 8 COAL) BOTTOM ELEVATION IS 460 TO 480 FT AMSL (AT LEAST 170 FT BELOW LANDFILL). SEAM THICKNESS IS 60 TO 65 INCHES

AEP MOUNTAINEER GENERATING PLANT - LBR LANDFILL
 BROAD RUN ROAD
 NEW HAVEN, WEST VIRGINIA

SURFACE WATER FEATURES



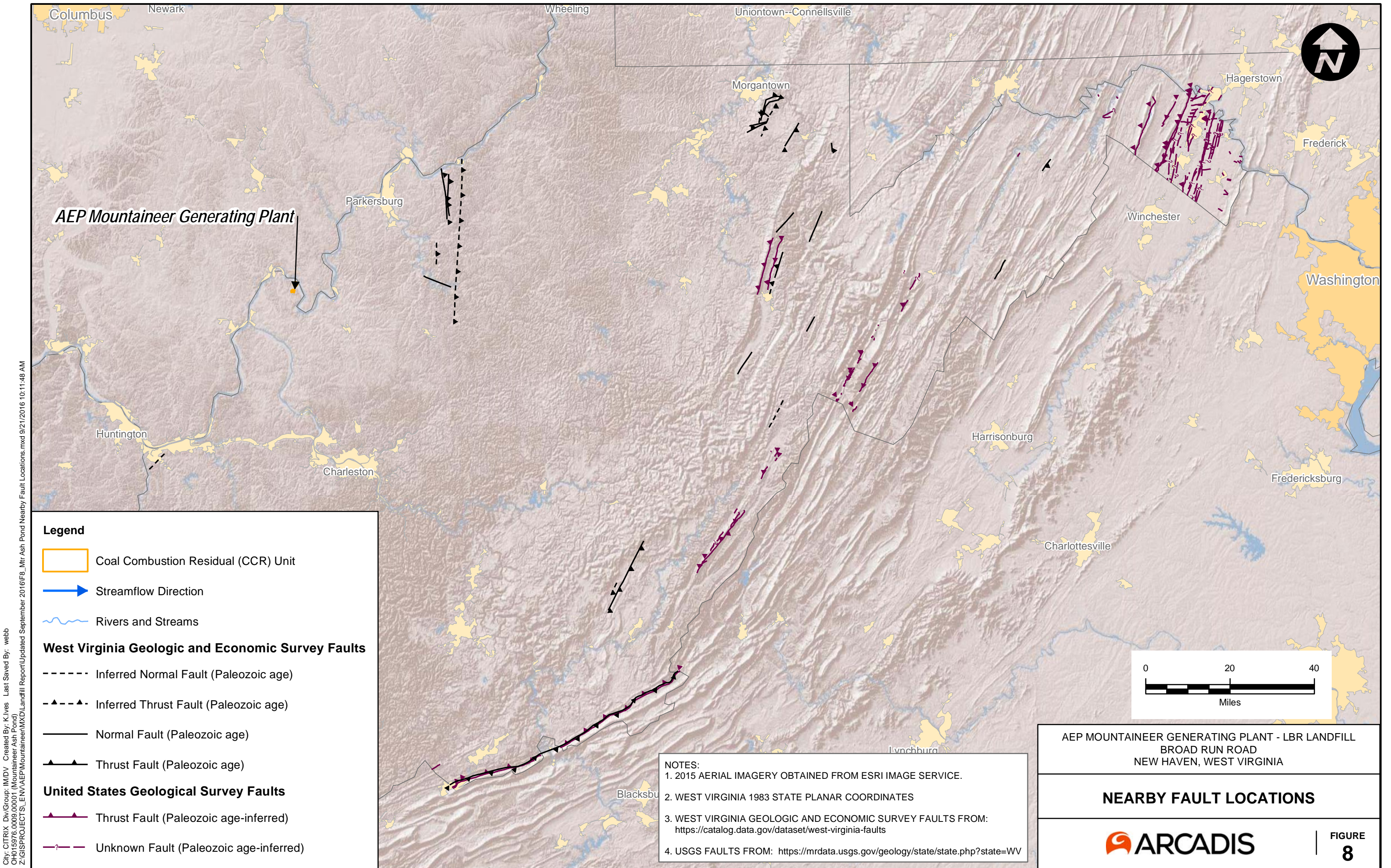

AEP Mountaineer Generating Plant

Legend

- Coal Combustion Residual (CCR) Unit
- ➔ Streamflow Direction
- ~ Rivers and Streams

West Virginia Geologic and Economic Survey Faults

- Inferred Normal Fault (Paleozoic age)
- ▲ Inferred Thrust Fault (Paleozoic age)
- Normal Fault (Paleozoic age)
- ▲ Thrust Fault (Paleozoic age)

United States Geological Survey Faults

- ▲ Thrust Fault (Paleozoic age-inferred)
- ? Unknown Fault (Paleozoic age-inferred)

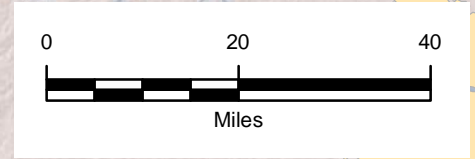

NOTES:

1. 2015 AERIAL IMAGERY OBTAINED FROM ESRI IMAGE SERVICE.
2. WEST VIRGINIA 1983 STATE PLANAR COORDINATES
3. WEST VIRGINIA GEOLOGIC AND ECONOMIC SURVEY FAULTS FROM: <https://catalog.data.gov/dataset/west-virginia-faults>
4. USGS FAULTS FROM: <https://mrdata.usgs.gov/geology/state/state.php?state=WV>

AEP MOUNTAINEER GENERATING PLANT - LBR LANDFILL
BROAD RUN ROAD
NEW HAVEN, WEST VIRGINIA

NEARBY FAULT LOCATIONS

ARCADIS

FIGURE 8

City: CITRIX Div/Group: IMDV Created By: K.Ives Last Saved By: webb
OH:015976.0009.00001 (Mountaineer Ash Pond)
Z:\GIS\PROJECTS\ENV\AEP\Mountaineer\MXD\Landfill Report\Updated September 2016\F8_Mir Ash Pond Nearby Fault Locations.mxd 9/21/2016 10:11:48 AM

G:\ENVCAD\Columbus-OH\ACT\0415976 - AEP MOUNTAINEER\09090003 - LANDFILL\AEP_MTR_LBR_LANDFILL_Seismic Figure IMPACTS.dwg LAYOUT: NEW HAVEN WV POND ACADVER: 18.1S (LMS TECH) PAGESETUP: --- PLOTSTYLETABLE: ACAD.CTB PLOTTED: 11/23/2015 10:10AM

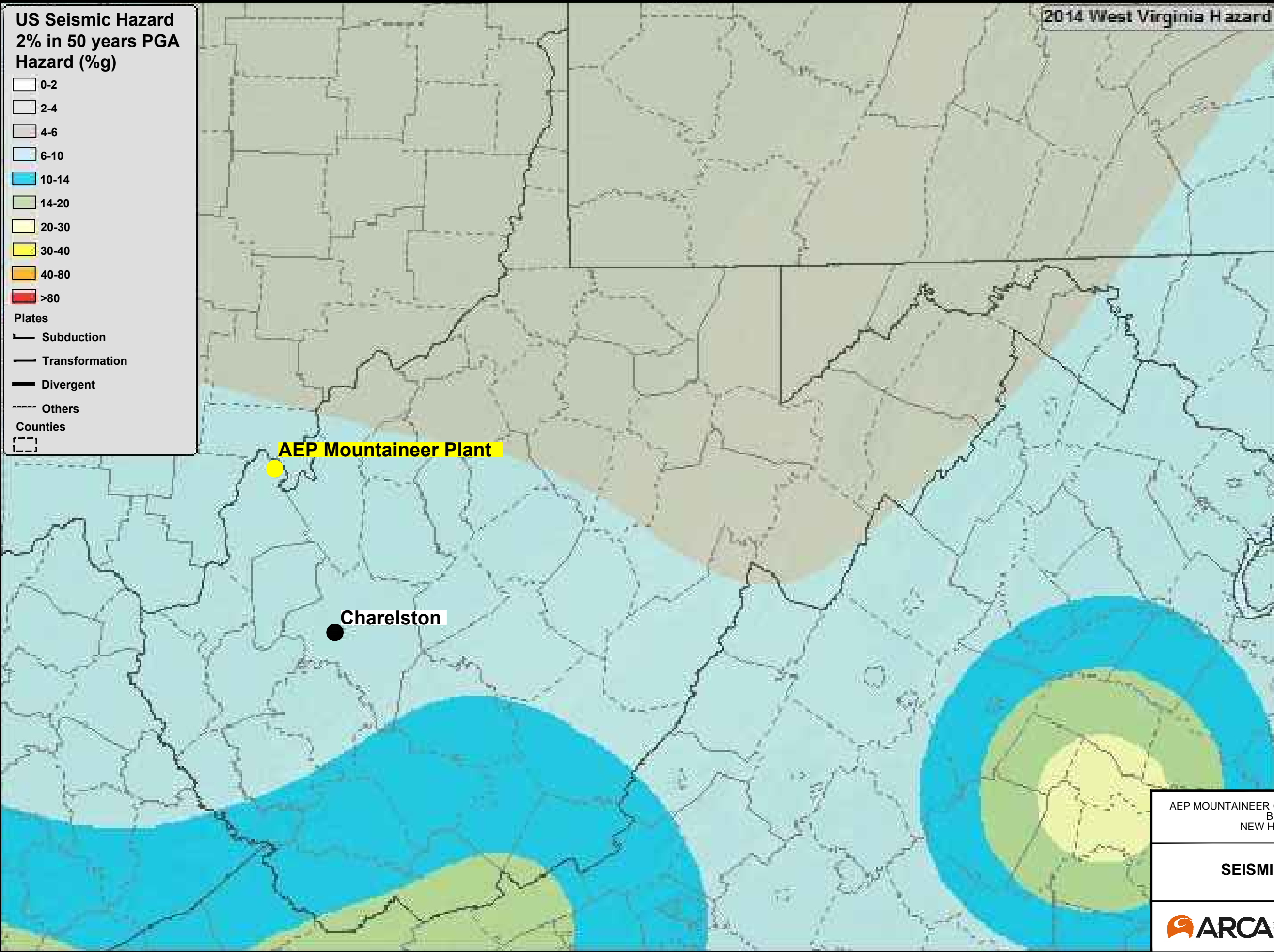

SOURCE:
USGS Earthquake Hazards Program,
West Virginia: 2014 Seismic Hazard
Map

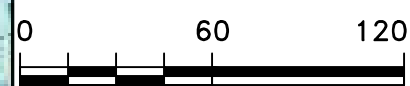

SCALE IN MILES
SCALE IS APPROXIMATE

AEP MOUNTAINEER GENERATING PLANT - LBR LANDFILL
BROAD RUN ROAD
NEW HAVEN, WEST VIRGINIA

SEISMIC IMPACT ZONES



G:\ENV\CAD\Columbus-OH\ACT\0101\9976 - AEP MOUNTAINEER MTR for landfill\LANDSLIDES AND RELATED FEATURES.dwg LAYOUT: AMOS WV AHS PONDS_LANDSLIDES PLOTTED: 9/21/2016 9:54 AM BY: SMITH, BOB



AEP Mountaineer Little Broad Run Landfill (Approximate)

LANDSLIDES AND RELATED FEATURES
OF THE NEW HAVEN, W.VA.-OHIO QUADRANGLE

by GREGORY C. GUMMACHER
U.S. Geological Survey
OPEN FILE MAP 85-80 (8-1)

NOTE: Information shown is intended as a general guide to ground conditions as of the date of field check. Additional landslides and rockfalls should be anticipated in all map units. The map unit depicts the dominant condition in the area delineated and variations in slope stability may occur at any point in the unit. This map is suitable for general planning purposes and as a supplement to more detailed studies for site selection. The map cannot be used as a substitute for detailed geologic and engineering investigations to establish design and construction criteria of specific sites. Some symbols may not appear on this map because the description is applicable to a series of maps.

LANDSLIDES AND RELATED FEATURES INTERPRETED FROM AERIAL PHOTOGRAPHS:
1:250,000 SCALE BLACK AND WHITE 1960
1:125,000 SCALE COLOR INFRARED 1973
1:80,000 SCALE BLACK AND WHITE 1975

Photointerpretation and field check 1978.
This map has not been edited or reviewed for conformity with Geological Survey standards and nomenclature.

ACTIVE OR RECENTLY ACTIVE LANDSLIDE
Complex landslide composed of earthflow, debris slide, earth and rock slump. Identified from historical records, and from scars, debris and other field evidence. Ground extremely unstable; sliding accelerated by excavation, loading and changes in drainage conditions. May include areas with several active slides too small to be shown separately.

OLD LANDSLIDE
Area of extensive hummocky ground caused by earthflow and earth and rock slump. Lacks clear evidence of active sliding. Relatively stable in natural, undisturbed state, generally not affected by small structures properly sited in areas away from the edge of the toe, can be reactivated by extensive, rapid excavation, loading, and changes in ground water and surface water conditions. Area of old landslide probably includes recent ones not identified from field evidence or otherwise documented. Upslope boundary of landslide generally defined by modified scarp, but downslope (toe) may be gradual and not well defined.

COLLECTED SLOPE
Valley wall along major streams with slope as steep as 40° (85%), stony, clayey silt soil up to 50 ft. (15 m) thick; commonly buttressed by a terrace or bench at the toe of the slope, very susceptible to sliding by cutting of toe area, removal of terrace or bench, and overloading. Slide commonly activated without apparent cause.

AREAS SUSCEPTIBLE TO DEBRIS FLOWS AND DEBRIS AVALANCHES
Primarily shallow, narrow ravines and chutes with accumulation of stony colluvium generally 10 ft. (3 m) or less in thickness; susceptible to rapid movement during intense rainfalls. Most ravines and chutes designated show evidence of former debris flows and avalanches. Symbol 2 designates historical debris flow or debris avalanche.

AREAS SUSCEPTIBLE TO ROCKFALL
Steep, locally vertical, natural and man-made slopes and cliffs, 15 ft. (4.5 m) or more high, formed dominantly of sandstone, limestone, sandy shale, mudstone and claystone. Interbedded mudstone, claystone and shale weather rapidly leaving sandstone and limestone rock faces unsupported.

SOIL AND ROCK SUSCEPTIBLE TO LANDSLIDING
Soil and rock similar to that involved in landslides elsewhere in map area; primarily areas underlain by claystone, mudstone and shale associated with other rock types. Rock weathers rapidly on exposure forming clayey soil highly susceptible to sliding. Includes coves (U-shaped, shallow valleys) containing thick layers of clayey soil that are very susceptible to sliding where excavation breaks continuity of slope and where overloaded by artificial fill.

AREAS LEAST PRONE TO LANDSLIDES
Map areas in which no patterns or symbols are shown, primarily valley floors, ridge tops and broad benches, modification by excavation and fill may lead to local landslides.

MAN-MADE FEATURES
Strip mines (combination of letter symbols indicates complex formed or more than one type of strip mine)
sh bench with high wall
st furrowed with high wall
sd multiple furrows and multiple benches
ss hilltop removed
srg reclaimed by grading
sru reclaimed by secondary use
sh/r regraded in part, high wall remains
Coal refuse banks identified on aerial photographs, not classified in field check
rb not burnt nor on fire
rbb burnt
rbd burning
rbs sludge
Quarries
q quarry site
Gravel pits
g site of gravel pit
Slides in man-made features
af earth flow in fill
a/s earth flow in strip castings
a/r earth flow in coal refuse

SOURCE: West Virginia Landslide Study, West Virginia Geological and Economic Survey by Robert B. Erwin, Director and State Geologist. Saint Albans 7.5' Quadrangle, 1975.

SOURCE: USGS National Geologic Map Database, Landslides and Related Features of the New Haven, West Virginia Quadrangle

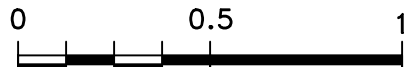

SCALE IN MILES
SCALE IS APPROXIMATE

AEP MOUNTAINEER GENERATING PLANT - LBR LANDFILL
BROAD RUN ROAD
NEW HAVEN, WEST VIRGINIA

NEARBY LANDSLIDES AND RELATED FEATURES



APPENDIX A

Boring/Well Construction Logs





AEP 1986, 1992

Boring Logs

B-400 to B-405, BFA-1

AMERICAN ELECTRIC POWER SERVICE CORPORATION
AEP CIVIL ENGINEERING LABORATORY
 LOG OF BORING



JOB NUMBER _____
 COMPANY **APPALACHIAN POWER COMPANY**
 PROJECT **MOUNTAINEER LBR LANDFILL**
 COORDINATES **N 713,091.5 E 1,734,431.1**
 GROUND ELEVATION **792.2** SYSTEM _____

BORING NO. **B-400** DATE **7/23/15** SHEET **1** OF **9**
 BORING START **3/12/86** BORING FINISH **3/18/86**
 PIEZOMETER TYPE _____ WELL TYPE _____
 HGT. RISER ABOVE GROUND _____ DIA _____
 DEPTH TO TOP OF WELL SCREEN _____ BOTTOM _____
 WELL DEVELOPMENT _____ BACKFILL _____
 FIELD PARTY **ROUSH/LAMBERT** RIG **B-61**

Water Level, ft	▽ 56.0	▼	▼
TIME			
DATE	5/2/1986		

SAMPLE NUMBER	SAMPLE	SAMPLE DEPTH IN FEET		STANDARD PENETRATION RESISTANCE BLOWS / 6"	TOTAL LENGTH RECOVERY	RQD %	DEPTH IN FEET	GRAPHIC LOG	USCS	SOIL / ROCK IDENTIFICATION	WELL	DRILLER'S NOTES
		FROM	TO									
		0.0	3.0							BROWN CLAY		
1	SS	3.0	4.5	2-3-6	1.2		5					
2	SS	8.0	8.2	50/2	0.1					GREENISH BROWN CLAY SHALE		Started coring @ 8.2'
3	NQ2	8.2	15.0		6.6		10			GREENISH BROWN SANDSTONE		
										GRAY SANDSTONE		
										BROWN SANDY SHALE		
4	NQ2	15.0	25.0		8.6		15			GRAY SANDSTONE		
										BROWN SANDSTONE		
										BROWN SHALE		
										GRAY SANDY SHALE		
										GRAY CLAY SHALE		
										GRAY SANDY SHALE		

TYPE OF CASING USED	
<input checked="" type="checkbox"/>	NQ-2 ROCK CORE
<input checked="" type="checkbox"/>	6" x 3.25 HSA
	9" x 6.25 HSA
	HW CASING ADVANCER 4"
	NW CASING 3"
	SW CASING 6"
	AIR HAMMER 8"

Continued Next Page

PIEZOMETER TYPE: PT = OPEN TUBE POROUS TIP, SS = OPEN TUBE SLOTTED SCREEN, G = GEONOR, P = PNEUMATIC

WELL TYPE: OW = OPEN TUBE SLOTTED SCREEN, GM = GEOMON

RECORDER **JCM**

AEP_Mt.LBR.LF.FKA.SI.GPJ.AEP.GDT.7/23/15

AMERICAN ELECTRIC POWER SERVICE CORPORATION
AEP CIVIL ENGINEERING LABORATORY
 LOG OF BORING



JOB NUMBER _____

COMPANY **APPALACHIAN POWER COMPANY**

BORING NO. **B-400** DATE **7/23/15** SHEET **2** OF **9**

PROJECT **MOUNTAINEER LBR LANDFILL**

BORING START **3/12/86** BORING FINISH **3/18/86**

SAMPLE NUMBER	SAMPLE	SAMPLE DEPTH IN FEET		STANDARD PENETRATION RESISTANCE BLOWS / 6"	TOTAL LENGTH RECOVERY	RQD	DEPTH IN FEET	GRAPHIC LOG	USCS	SOIL / ROCK IDENTIFICATION	WELL	DRILLER'S NOTES
		FROM	TO			%						
										GRAY CLAY SHALE GRAY SANDY SHALE		
5	NQ2	25.0	35.0		9.3		25			MULTI COLOR CLAY SHALE GRAY SANDSTONE GRAY SANDY SHALE GRAY SANDSTONE GRAY CLAY SHALE		
							30			MULTI COLOR CLAY SHALE RED CLAY SHALE		
6	NQ2	35.0	45.0		9.8		35			GRAY CLAY SHALE		
							40					
7	NQ2	45.0	55.0		10.0		45			GRAY SANDSTONE		

AEP_Mt.LBR.LF.FKA.SI.GPJ_AEP.GDT_7/23/15

Continued Next Page

AMERICAN ELECTRIC POWER SERVICE CORPORATION
AEP CIVIL ENGINEERING LABORATORY
 LOG OF BORING



JOB NUMBER _____

COMPANY **APPALACHIAN POWER COMPANY**

BORING NO. **B-400** DATE **7/23/15** SHEET **3** OF **9**

PROJECT **MOUNTAINEER LBR LANDFILL**

BORING START **3/12/86** BORING FINISH **3/18/86**

SAMPLE NUMBER	SAMPLE	SAMPLE DEPTH IN FEET		STANDARD PENETRATION RESISTANCE BLOWS / 6"	TOTAL LENGTH RECOVERY	RQD	DEPTH IN FEET	GRAPHIC LOG	USCS	SOIL / ROCK IDENTIFICATION	WELL	DRILLER'S NOTES
		FROM	TO			%						
							50			GREENISH BROWN SANDY SHALE GREENISH BROWN COARSE GRAIN SANDSTONE		
8	NQ2	55.0	65.0		10.0		55				▽	
							60					
9	NQ2	65.0	75.0		10.0		65			GRAY COARSE GRAIN SANDSTONE		
							70					

AEP MT LBR LF FKA SJGPJ AEP.GDT 7/23/15

Continued Next Page

AMERICAN ELECTRIC POWER SERVICE CORPORATION
AEP CIVIL ENGINEERING LABORATORY
 LOG OF BORING



JOB NUMBER _____

COMPANY **APPALACHIAN POWER COMPANY**

BORING NO. **B-400** DATE **7/23/15** SHEET **4** OF **9**

PROJECT **MOUNTAINEER LBR LANDFILL**

BORING START **3/12/86** BORING FINISH **3/18/86**

SAMPLE NUMBER	SAMPLE	SAMPLE DEPTH IN FEET		STANDARD PENETRATION RESISTANCE BLOWS / 6"	TOTAL LENGTH RECOVERY	RQD	DEPTH IN FEET	GRAPHIC LOG	USCS	SOIL / ROCK IDENTIFICATION	WELL	DRILLER'S NOTES
		FROM	TO			%						
10	NQ2	75.0	80.0		4.9		75			GREENISH COARSE GRAIN SANDSTONE		
										GRAY CLAY SHALE		
11	NQ2	80.0	85.0		5.0		80			MULTI COLOR CLAY SHALE		
										GRAY CLAY SHALE		
12	NQ2	85.0	95.0		10.0		85					
							90			RED CLAY SHALE		
										GRAY CLAY SHALE		
										RED & GRAY CLAY SHALE		
13	NQ2	95.0	105.0		10.0		95			GRAY CLAY SHALE		

AEP MT LBR LF FKA SI/GPJ AEP.GDT 7/23/15

Continued Next Page

AMERICAN ELECTRIC POWER SERVICE CORPORATION
AEP CIVIL ENGINEERING LABORATORY
 LOG OF BORING



JOB NUMBER _____

COMPANY **APPALACHIAN POWER COMPANY**

BORING NO. **B-400** DATE **7/23/15** SHEET **5** OF **9**

PROJECT **MOUNTAINEER LBR LANDFILL**

BORING START **3/12/86** BORING FINISH **3/18/86**

SAMPLE NUMBER	SAMPLE	SAMPLE DEPTH IN FEET		STANDARD PENETRATION RESISTANCE BLOWS / 6"	TOTAL LENGTH RECOVERY	RQD	DEPTH IN FEET	GRAPHIC LOG	USCS	SOIL / ROCK IDENTIFICATION	WELL	DRILLER'S NOTES
		FROM	TO			%						
							100			RED CLAY SHALE		
										GRAY CLAY SHALE		
										GRAY SANDSTONE GRAY CLAY SHALE		
14	NQ2	105.0	110.0		4.8		105			RED CLAY SHALE		
							110			GRAY CLAY SHALE		
15	NQ2	110.0	115.0		5.0		115			RED & GRAY CLAY SHALE		
										GRAY CLAY SHALE		
16	NQ2	115.0	125.0		10.0		120			GRAY CLAY SHALE		
										RED & GRAY CLAY SHALE		
										GRAY CLAY SHALE		
										RED & GRAY CLAY SHALE		
										GRAY CLAY SHALE		
										RED CLAY SHALE		
										GRAY CLAY SHALE		
										MULTI COLOR CLAY SHALE		

AEP MT LBR LF FKA SI/GPJ AEP.GDT 7/23/15

Continued Next Page

AMERICAN ELECTRIC POWER SERVICE CORPORATION
AEP CIVIL ENGINEERING LABORATORY
 LOG OF BORING



JOB NUMBER _____

COMPANY **APPALACHIAN POWER COMPANY**

BORING NO. **B-400** DATE **7/23/15** SHEET **7** OF **9**

PROJECT **MOUNTAINEER LBR LANDFILL**

BORING START **3/12/86** BORING FINISH **3/18/86**

SAMPLE NUMBER	SAMPLE	SAMPLE DEPTH IN FEET		STANDARD PENETRATION RESISTANCE BLOWS / 6"	TOTAL LENGTH RECOVERY	RQD	DEPTH IN FEET	GRAPHIC LOG	USCS	SOIL / ROCK IDENTIFICATION	WELL	DRILLER'S NOTES
		FROM	TO			%						
										GRAY SILTSTONE		
										RED CLAY SHALE GRAY SILTSTONE		
21	NQ2	155.0	165.0		10.0		155			GRAY SANDSTONE GRAY CLAY SHALE RED & GRAY CLAY SHALE RED CLAY SHALE		
							160					
22	NQ2	165.0	175.0		9.7		165			GRAY CLAY SHALE GRAY SANDSTONE		
							170			GRAY CLAY SHALE RED CLAY SHALE GRAY SILTSTONE RED SILTSTONE GRAY SILTSTONE		
23	NQ2	175.0	185.0		9.9		175			GRAY SANDSTONE		

AEP MT LBR LF FKA SI/GPJ AEP.GDT 7/23/15

Continued Next Page

AMERICAN ELECTRIC POWER SERVICE CORPORATION
AEP CIVIL ENGINEERING LABORATORY
 LOG OF BORING



JOB NUMBER _____

COMPANY **APPALACHIAN POWER COMPANY**

BORING NO. **B-400** DATE **7/23/15** SHEET **9** OF **9**

PROJECT **MOUNTAINEER LBR LANDFILL**

BORING START **3/12/86** BORING FINISH **3/18/86**

SAMPLE NUMBER	SAMPLE	SAMPLE DEPTH IN FEET		STANDARD PENETRATION RESISTANCE BLOWS / 6"	TOTAL LENGTH RECOVERY	RQD	DEPTH IN FEET	GRAPHIC LOG	USCS	SOIL / ROCK IDENTIFICATION	WELL	DRILLER'S NOTES
		FROM	TO			%						
							205			RED CLAY SHALE		
							210			GRAY CLAY SHALE		
												Stopped boring @ 210.0' on 3/18/1986

AMERICAN ELECTRIC POWER SERVICE CORPORATION
AEP CIVIL ENGINEERING LABORATORY
 LOG OF BORING



JOB NUMBER _____
 COMPANY **APPALACHIAN POWER COMPANY**
 PROJECT **MOUNTAINEER LBR LANDFILL**
 COORDINATES **N 713,554.3 E 1,730,964.3**
 GROUND ELEVATION **692.1** SYSTEM _____

BORING NO. **B-401** DATE **7/23/15** SHEET **1** OF **5**
 BORING START **4/3/86** BORING FINISH **4/7/86**
 PIEZOMETER TYPE _____ WELL TYPE _____
 HGT. RISER ABOVE GROUND _____ DIA _____
 DEPTH TO TOP OF WELL SCREEN _____ BOTTOM _____
 WELL DEVELOPMENT _____ BACKFILL _____
 FIELD PARTY **ROUSH/LAMBERT** RIG **B-61**

Water Level, ft	▽ 27.7	▼	▼
TIME			
DATE	5/2/1986		

SAMPLE NUMBER	SAMPLE	SAMPLE DEPTH IN FEET		STANDARD PENETRATION RESISTANCE BLOWS / 6"	TOTAL LENGTH RECOVERY	RQD %	DEPTH IN FEET	GRAPHIC LOG	USCS	SOIL / ROCK IDENTIFICATION	WELL	DRILLER'S NOTES
		FROM	TO									
		0.0	2.5							REDDISH BROWN CLAY		
1	SS	2.5	4.0	4-10-13	1.0		5			REDDISH BROWN CLAYEY SAND		
2	SS	7.5	9.0	3-6-8	1.4		10			BROWN SANDSTONE IN END OF SPOON		
3	SS	12.5	13.9	10-14-50/.5	1.3		15			BROWN SANDSTONE		
4	SS	17.5	17.6	50/.1	0							Auger refusal @ 18.1'. Moved over 3.0', drilled casing to 18.0' and started coring.
5	NQ2	18.0	25.3		7.3	100						

TYPE OF CASING USED	
<input checked="" type="checkbox"/>	NQ-2 ROCK CORE
<input checked="" type="checkbox"/>	6" x 3.25 HSA
	9" x 6.25 HSA
	HW CASING ADVANCER 4"
	NW CASING 3"
	SW CASING 6"
	AIR HAMMER 8"

Continued Next Page

PIEZOMETER TYPE: PT = OPEN TUBE POROUS TIP, SS = OPEN TUBE SLOTTED SCREEN, G = GEONOR, P = PNEUMATIC

WELL TYPE: OW = OPEN TUBE SLOTTED SCREEN, GM = GEOMON

RECORDER **JCM**

AEP_Mt.LBR.LF.FKA.SI.GPJ.AEP.GDT.7/23/15

AMERICAN ELECTRIC POWER SERVICE CORPORATION
AEP CIVIL ENGINEERING LABORATORY
 LOG OF BORING



JOB NUMBER _____

COMPANY **APPALACHIAN POWER COMPANY**

BORING NO. **B-401** DATE **7/23/15** SHEET **2** OF **5**

PROJECT **MOUNTAINEER LBR LANDFILL**

BORING START **4/3/86** BORING FINISH **4/7/86**

SAMPLE NUMBER	SAMPLE	SAMPLE DEPTH IN FEET		STANDARD PENETRATION RESISTANCE BLOWS / 6"	TOTAL LENGTH RECOVERY	RQD	DEPTH IN FEET	GRAPHIC LOG	USCS	SOIL / ROCK IDENTIFICATION	WELL	DRILLER'S NOTES
		FROM	TO			%						
										GRAY SANDSTONE		
										BROWN SANDSTONE GRAY SANDSTONE		
6	NQ2	25.3	33.4		4.5	39	25			BROWN SANDY SHALE GRAY SANDY SHALE BADLY BROKEN GRAY CLAY SHALE BADLY BROKEN RED CLAY SHALE	▽	
7	NQ2	33.4	35.3		1.6	52	30					
8	NQ2	35.3	45.3		10	77	35			RED CLAY SHALE		
										GRAY CLAY SHALE		
							40			RED CLAY SHALE		
										GRAY CLAY SHALE		
										GRAY SANDSTONE		
										GRAY CLAY SHALE		
										RED CLAY SHALE		
9	NQ2	45.3	55.3		10	100	45			GRAY CLAY SHALE		

AEP_MT_LBR_LF_FKA_SJ.GPJ AEP.GDT 7/23/15

Continued Next Page

AMERICAN ELECTRIC POWER SERVICE CORPORATION
AEP CIVIL ENGINEERING LABORATORY
 LOG OF BORING



JOB NUMBER _____

COMPANY **APPALACHIAN POWER COMPANY**

BORING NO. **B-401** DATE **7/23/15** SHEET **3** OF **5**

PROJECT **MOUNTAINEER LBR LANDFILL**

BORING START **4/3/86** BORING FINISH **4/7/86**

SAMPLE NUMBER	SAMPLE	SAMPLE DEPTH IN FEET		STANDARD PENETRATION RESISTANCE BLOWS / 6"	TOTAL LENGTH RECOVERY	RQD		DEPTH IN FEET	GRAPHIC LOG	USCS	SOIL / ROCK IDENTIFICATION	WELL	DRILLER'S NOTES
		FROM	TO			%	%						
								50					
10	NQ2	55.3	65.3		9.9	88		55			GRAY SANDY SHALE		
								60					
								65			GRAY SANDSTONE		
11	NQ2	65.3	70.3		4.9	98		65			RED & GRAY CLAY SHALE		
								70					
12	NQ2	70.3	75.3		4.6	76		70			GRAY CLAY SHALE		

AEP_Mt.LBR.LF.FKA.SI.GPJ_AEP.GDT_7/23/15

Continued Next Page

AMERICAN ELECTRIC POWER SERVICE CORPORATION
AEP CIVIL ENGINEERING LABORATORY
 LOG OF BORING



JOB NUMBER _____

COMPANY **APPALACHIAN POWER COMPANY**

BORING NO. **B-401** DATE **7/23/15** SHEET **4** OF **5**

PROJECT **MOUNTAINEER LBR LANDFILL**

BORING START **4/3/86** BORING FINISH **4/7/86**

SAMPLE NUMBER	SAMPLE	SAMPLE DEPTH IN FEET		STANDARD PENETRATION RESISTANCE BLOWS / 6"	TOTAL LENGTH RECOVERY	RQD		DEPTH IN FEET	GRAPHIC LOG	USCS	SOIL / ROCK IDENTIFICATION	WELL	DRILLER'S NOTES
		FROM	TO			%							
								75			RED & GRAY CLAY SHALE		
13	NQ2	75.3	84.3		3.9						RED CLAY SHALE		
								80			GRAY CLAY SHALE		
											GRAY SILTSTONE		
14	NQ2	84.3	94.3		9.9	100		85			GRAY CLAY SHALE		
								90					
15	NQ2	94.3	100.0		5.6	95		95			RED CLAY SHALE		

AEP MT LBR LF FKA SI/GPJ AEP.GDT 7/23/15

Continued Next Page

AMERICAN ELECTRIC POWER SERVICE CORPORATION
AEP CIVIL ENGINEERING LABORATORY
 LOG OF BORING



JOB NUMBER _____

COMPANY **APPALACHIAN POWER COMPANY**

BORING NO. **B-401** DATE **7/23/15** SHEET **5** OF **5**

PROJECT **MOUNTAINEER LBR LANDFILL**

BORING START **4/3/86** BORING FINISH **4/7/86**

SAMPLE NUMBER	SAMPLE	SAMPLE DEPTH IN FEET		STANDARD PENETRATION RESISTANCE BLOWS / 6"	TOTAL LENGTH RECOVERY	RQD	DEPTH IN FEET	GRAPHIC LOG	USCS	SOIL / ROCK IDENTIFICATION	WELL	DRILLER'S NOTES
		FROM	TO			%						
							100					Stopped boring @ 100.0' on 4/1/1986

AMERICAN ELECTRIC POWER SERVICE CORPORATION
AEP CIVIL ENGINEERING LABORATORY
 LOG OF BORING



JOB NUMBER _____
 COMPANY **APPALACHIAN POWER COMPANY**
 PROJECT **MOUNTAINEER LBR LANDFILL**
 COORDINATES **N 712,518.0 E 1,730,842.0**
 GROUND ELEVATION **813.1** SYSTEM _____

BORING NO. **B-402** DATE **7/23/15** SHEET **1** OF **10**
 BORING START **3/19/86** BORING FINISH **3/24/86**
 PIEZOMETER TYPE _____ WELL TYPE _____
 HGT. RISER ABOVE GROUND _____ DIA _____
 DEPTH TO TOP OF WELL SCREEN _____ BOTTOM _____
 WELL DEVELOPMENT _____ BACKFILL _____
 FIELD PARTY **ROUSH/LAMBERT** RIG **B-61**

Water Level, ft	▽ 62.7	▼	▼
TIME			
DATE	5/2/1986		

SAMPLE NUMBER	SAMPLE	SAMPLE DEPTH IN FEET		STANDARD PENETRATION RESISTANCE BLOWS / 6"	TOTAL LENGTH RECOVERY	RQD %	DEPTH IN FEET	GRAPHIC LOG	USCS	SOIL / ROCK IDENTIFICATION	WELL	DRILLER'S NOTES
		FROM	TO									
		0.0	5.0									Drilled casing to 5.0' and started coring.
1	NQ2	5.0	14.4		9.4	82	5			BROWN SHALE		
2	NQ2	14.4	24.4		9.5	80	15			BROWN SANDY SHALE BROWN SANDSTONE GREENISH BROWN SANDSTONE BROWN CLAY SHALE GREENISH BROWN SANDSTONE GREENISH BROWN CLAY SHALE GRAY CLAY SHALE		

TYPE OF CASING USED				<i>Continued Next Page</i>			
X	NQ-2 ROCK CORE			PIEZOMETER TYPE: PT = OPEN TUBE POROUS TIP, SS = OPEN TUBE SLOTTED SCREEN, G = GEONOR, P = PNEUMATIC			
	6" x 3.25 HSA			WELL TYPE: OW = OPEN TUBE SLOTTED SCREEN, GM = GEOMON			
	9" x 6.25 HSA			RECORDER JCM			
	HW CASING ADVANCER	4"					
	NW CASING	3"					
	SW CASING	6"					
	AIR HAMMER	8"					

AEP_Mt.LBR.LF.FKA.SI.GPJ.AEP.GDT.7/23/15

AMERICAN ELECTRIC POWER SERVICE CORPORATION
AEP CIVIL ENGINEERING LABORATORY
 LOG OF BORING



JOB NUMBER _____

COMPANY **APPALACHIAN POWER COMPANY**

BORING NO. **B-402** DATE **7/23/15** SHEET **2** OF **10**

PROJECT **MOUNTAINEER LBR LANDFILL**

BORING START **3/19/86** BORING FINISH **3/24/86**

SAMPLE NUMBER	SAMPLE	SAMPLE DEPTH IN FEET		STANDARD PENETRATION RESISTANCE BLOWS / 6"	TOTAL LENGTH RECOVERY	RQD	DEPTH IN FEET	GRAPHIC LOG	USCS	SOIL / ROCK IDENTIFICATION	WELL	DRILLER'S NOTES
		FROM	TO			%						
3	NQ2	24.4	34.4		8.5	83	25			GRAY SANDSTONE		
										GRAY CLAY SHALE		
										RED & GRAY CLAY SHALE		
4	NQ2	34.4	44.4		9.9	88	35			RED CLAY SHALE		
										GRAY CLAY SHALE		
5	NQ2	44.4	54.4		9.9	98	45			GREENISH BROWN SANDSTONE		

AEP MT LBR LF FKA SJ/GPJ AEP.GDT 7/23/15

Continued Next Page

AMERICAN ELECTRIC POWER SERVICE CORPORATION
AEP CIVIL ENGINEERING LABORATORY
 LOG OF BORING



JOB NUMBER _____

COMPANY **APPALACHIAN POWER COMPANY**

BORING NO. **B-402** DATE **7/23/15** SHEET **3** OF **10**

PROJECT **MOUNTAINEER LBR LANDFILL**

BORING START **3/19/86** BORING FINISH **3/24/86**

SAMPLE NUMBER	SAMPLE	SAMPLE DEPTH IN FEET		STANDARD PENETRATION RESISTANCE BLOWS / 6"	TOTAL LENGTH RECOVERY	RQD	DEPTH IN FEET	GRAPHIC LOG	USCS	SOIL / ROCK IDENTIFICATION	WELL	DRILLER'S NOTES
		FROM	TO			%						
							50					
6	NQ2	54.4	64.4		10	100	55					
							60					
											▽	
7	NQ2	64.4	74.4		9.8	87	65			WHITE SANDSTONE		
										GREENISH WHITE SANDSTONE		
										GREENISH BROWN SHALE		
										GREENISH BROWN SANDSTONE		
										GRAY SANDSTONE		
							70					

AEP MT LBR LF FKA SJGPJ AEP.GDT 7/23/15

Continued Next Page

AMERICAN ELECTRIC POWER SERVICE CORPORATION
AEP CIVIL ENGINEERING LABORATORY
 LOG OF BORING



JOB NUMBER _____

COMPANY **APPALACHIAN POWER COMPANY**

BORING NO. **B-402** DATE **7/23/15** SHEET **4** OF **10**

PROJECT **MOUNTAINEER LBR LANDFILL**

BORING START **3/19/86** BORING FINISH **3/24/86**

SAMPLE NUMBER	SAMPLE	SAMPLE DEPTH IN FEET		STANDARD PENETRATION RESISTANCE BLOWS / 6"	TOTAL LENGTH RECOVERY	RQD	DEPTH IN FEET	GRAPHIC LOG	USCS	SOIL / ROCK IDENTIFICATION	WELL	DRILLER'S NOTES	
		FROM	TO			%							
8	NQ2	74.4	84.4		10.2	100	75			GRAY CLAY SHALE		Picked up 0.2' of recovery from previous run.	
										RED CLAY SHALE			
9	NQ2	84.4	94.4		10	100	85			GRAY CLAY SHALE			
										RED & GRAY CLAY SHALE			
										GRAY SANDSTONE			
10	NQ2	94.4	104.4		9.5	98	95			GRAY CLAY SHALE			
										RED & GRAY CLAY SHALE			
										GRAY SILTSTONE			
										GRAY CLAY SHALE			

AEP MT LBR LF FKA SI/GPJ AEP.GDT 7/23/15

Continued Next Page

AMERICAN ELECTRIC POWER SERVICE CORPORATION
AEP CIVIL ENGINEERING LABORATORY
 LOG OF BORING



JOB NUMBER _____

COMPANY **APPALACHIAN POWER COMPANY**

BORING NO. **B-402** DATE **7/23/15** SHEET **5** OF **10**

PROJECT **MOUNTAINEER LBR LANDFILL**

BORING START **3/19/86** BORING FINISH **3/24/86**

SAMPLE NUMBER	SAMPLE	SAMPLE DEPTH IN FEET		STANDARD PENETRATION RESISTANCE BLOWS / 6"	TOTAL LENGTH RECOVERY	RQD	DEPTH IN FEET	GRAPHIC LOG	USCS	SOIL / ROCK IDENTIFICATION	WELL	DRILLER'S NOTES
		FROM	TO			%						
							100			GRAY SANDSTONE		
										GRAY CLAY SHALE		
11	NQ2	104.4	114.4		10	100	105			RED CLAY SHALE		
										GRAY SANDY CLAY SHALE		
							110			GRAY SANDSTONE		
12	NQ2	114.4	124.4		9.8	98	115			GRAY CLAY SHALE		
										RED CLAY SHALE		
										MULTI COLOR CLAY SHALE		
										GRAY CLAY SHALE		
							120			GRAY SANDSTONE		

AEP MT LBR LF FKA SI/GPJ AEP.GDT 7/23/15

Continued Next Page

AMERICAN ELECTRIC POWER SERVICE CORPORATION
AEP CIVIL ENGINEERING LABORATORY
 LOG OF BORING



JOB NUMBER _____

COMPANY **APPALACHIAN POWER COMPANY**

BORING NO. **B-402** DATE **7/23/15** SHEET **6** OF **10**

PROJECT **MOUNTAINEER LBR LANDFILL**

BORING START **3/19/86** BORING FINISH **3/24/86**

SAMPLE NUMBER	SAMPLE	SAMPLE DEPTH IN FEET		STANDARD PENETRATION RESISTANCE BLOWS / 6"	TOTAL LENGTH RECOVERY		DEPTH IN FEET	GRAPHIC LOG	USCS	SOIL / ROCK IDENTIFICATION	WELL	DRILLER'S NOTES
		FROM	TO		%	RQD						
13	NQ2	124.4	134.4		9.5	89	125					
										GRAY CLAY SHALE		
										MULTI COLOR CLAY SHALE		
							130					
14	NQ2	134.4	144.4		9.9	90	135			RED CLAY SHALE		
										GRAY CLAY SHALE		
										GRAY SILTSTONE		
							140					
										GRAY SANDSTONE		
15	NQ2	144.4	154.4		9.5	94	145					

AEP MT LBR LF FKA SI/GPJ AEP.GDT 7/23/15

Continued Next Page

AMERICAN ELECTRIC POWER SERVICE CORPORATION
AEP CIVIL ENGINEERING LABORATORY
 LOG OF BORING



JOB NUMBER _____

COMPANY **APPALACHIAN POWER COMPANY**

BORING NO. **B-402** DATE **7/23/15** SHEET **7** OF **10**

PROJECT **MOUNTAINEER LBR LANDFILL**

BORING START **3/19/86** BORING FINISH **3/24/86**

SAMPLE NUMBER	SAMPLE	SAMPLE DEPTH IN FEET		STANDARD PENETRATION RESISTANCE BLOWS / 6"	TOTAL LENGTH RECOVERY	RQD	DEPTH IN FEET	GRAPHIC LOG	USCS	SOIL / ROCK IDENTIFICATION	WELL	DRILLER'S NOTES
		FROM	TO			%						
										GRAY CLAY SHALE		
										RED CLAY SHALE		
16	NQ2	154.4	164.4		9.9	80	155					
							160					
										GRAY CLAY SHALE		
17	NQ2	164.4	174.4		10	100	165					
							170					
										GRAY SANDSTONE		
18	NQ2	174.4	184.4		10	100	175					

AEP MT LBR LF FKA SI/GPJ AEP.GDT 7/23/15

Continued Next Page

AMERICAN ELECTRIC POWER SERVICE CORPORATION
AEP CIVIL ENGINEERING LABORATORY
 LOG OF BORING



JOB NUMBER _____

COMPANY **APPALACHIAN POWER COMPANY**

BORING NO. **B-402** DATE **7/23/15** SHEET **8** OF **10**

PROJECT **MOUNTAINEER LBR LANDFILL**

BORING START **3/19/86** BORING FINISH **3/24/86**

SAMPLE NUMBER	SAMPLE	SAMPLE DEPTH IN FEET		STANDARD PENETRATION RESISTANCE BLOWS / 6"	TOTAL LENGTH RECOVERY	RQD	DEPTH IN FEET	GRAPHIC LOG	USCS	SOIL / ROCK IDENTIFICATION	WELL	DRILLER'S NOTES
		FROM	TO			%						
							180					
19	NQ2	184.4	194.4		9.2	98	185					
							190					
										GRAY SILTSTONE		
										RED CLAY SHALE		
20	NQ2	194.4	204.4		10	79	195			RED & GRAY CLAY SHALE		
										GRAY CLAY SHALE		
							200			RED & GRAY CLAY SHALE		
										RED CLAY SHALE		

AEP MT LBR LF FKA SJ/GPJ AEP.GDT 7/23/15

Continued Next Page

AMERICAN ELECTRIC POWER SERVICE CORPORATION
AEP CIVIL ENGINEERING LABORATORY
 LOG OF BORING



JOB NUMBER _____

COMPANY **APPALACHIAN POWER COMPANY**

BORING NO. **B-402** DATE **7/23/15** SHEET **9** OF **10**

PROJECT **MOUNTAINEER LBR LANDFILL**

BORING START **3/19/86** BORING FINISH **3/24/86**

SAMPLE NUMBER	SAMPLE	SAMPLE DEPTH IN FEET		STANDARD PENETRATION RESISTANCE BLOWS / 6"	TOTAL LENGTH RECOVERY	RQD %	DEPTH IN FEET	GRAPHIC LOG	USCS	SOIL / ROCK IDENTIFICATION	WELL	DRILLER'S NOTES
		FROM	TO									
21	NQ2	204.4	214.4		9.9	98	205			MULTI COLOR CLAY SHALE		
										GRAY CLAY SHALE		
							210			GRAY SILTSTONE		
										GRAY SANDSTONE		
22	NQ2	214.4	224.4		10	100	215			GRAY CLAY SHALE		
							220			MULTI COLOR CLAY SHALE		
23	NQ2	224.4	230.0		4.9	78	225					

AEP_Mt.LBR.LF.FKA.SI.GPJ_AEP.GDT_7/23/15

Continued Next Page

AMERICAN ELECTRIC POWER SERVICE CORPORATION
AEP CIVIL ENGINEERING LABORATORY
 LOG OF BORING



JOB NUMBER _____

COMPANY **APPALACHIAN POWER COMPANY**

BORING NO. **B-402** DATE **7/23/15** SHEET **10** OF **10**

PROJECT **MOUNTAINEER LBR LANDFILL**

BORING START **3/19/86** BORING FINISH **3/24/86**

SAMPLE NUMBER	SAMPLE	SAMPLE DEPTH IN FEET		STANDARD PENETRATION RESISTANCE BLOWS / 6"	TOTAL LENGTH RECOVERY	RQD	DEPTH IN FEET	GRAPHIC LOG	USCS	SOIL / ROCK IDENTIFICATION	WELL	DRILLER'S NOTES
		FROM	TO			%						
							230					Stopped boring @ 230.0' on 3/24/1986

AMERICAN ELECTRIC POWER SERVICE CORPORATION
AEP CIVIL ENGINEERING LABORATORY
 LOG OF BORING



JOB NUMBER _____
 COMPANY **APPALACHIAN POWER COMPANY**
 PROJECT **MOUNTAINEER LBR LANDFILL**
 COORDINATES **N 709,726.8 E 1,731,757.6**
 GROUND ELEVATION **854.6** SYSTEM _____

BORING NO. **B-403** DATE **7/23/15** SHEET **1** OF **12**
 BORING START **2/5/86** BORING FINISH _____
 PIEZOMETER TYPE _____ WELL TYPE **GM**
 HGT. RISER ABOVE GROUND **1.74-1.74** DIA **3"**
 DEPTH TO TOP OF WELL SCREEN _____ BOTTOM _____
 WELL DEVELOPMENT **SEE NOTES** BACKFILL **CEMENT/BENTONIT**
 FIELD PARTY **ROUSH/LAMBERT** RIG **B-61**

Water Level, ft	▽ 14.0	▼	▼
TIME			
DATE	02-06-86		

SAMPLE NUMBER	SAMPLE	SAMPLE DEPTH IN FEET		STANDARD PENETRATION RESISTANCE BLOWS / 6"	TOTAL LENGTH RECOVERY	RQD %	DEPTH IN FEET	GRAPHIC LOG	USCS	SOIL / ROCK IDENTIFICATION	WELL	DRILLER'S NOTES
		FROM	TO									
										AUGERED		Wells MW-1 and MW-2 were installed in boring B-403.
1	NQ	7.2	14.7		7.5	92	5			BROWN CLAYSHALE		
2	NQ	14.7	24.7		10	90	15			BROWN SANDY SHALE BROWN CLAYSHALE BROWN SANDY SHALE BROWN SANDSTONE GRAY SANDSTONE		

TYPE OF CASING USED	
<input checked="" type="checkbox"/>	NQ-2 ROCK CORE
	6" x 3.25 HSA
	9" x 6.25 HSA
	HW CASING ADVANCER 4"
<input checked="" type="checkbox"/>	NW CASING 3"
	SW CASING 6"
	AIR HAMMER 8"

Continued Next Page

PIEZOMETER TYPE: PT = OPEN TUBE POROUS TIP, SS = OPEN TUBE SLOTTED SCREEN, G = GEONOR, P = PNEUMATIC

WELL TYPE: OW = OPEN TUBE SLOTTED SCREEN, GM = GEOMON

RECORDER **JCM**

AEP_Mt.LBR.LF.FKA.SI.GPJ.AEP.GDT.7/23/15

AMERICAN ELECTRIC POWER SERVICE CORPORATION
AEP CIVIL ENGINEERING LABORATORY
 LOG OF BORING



JOB NUMBER _____

COMPANY **APPALACHIAN POWER COMPANY**

BORING NO. **B-403** DATE **7/23/15** SHEET **2** OF **12**

PROJECT **MOUNTAINEER LBR LANDFILL**

BORING START **2/5/86** BORING FINISH _____

SAMPLE NUMBER	SAMPLE	SAMPLE DEPTH IN FEET		STANDARD PENETRATION RESISTANCE BLOWS / 6"	TOTAL LENGTH RECOVERY	RQD %	DEPTH IN FEET	GRAPHIC LOG	USCS	SOIL / ROCK IDENTIFICATION	WELL	DRILLER'S NOTES
		FROM	TO									
3	NQ	24.7	34.7		10	100	25			RED CLAYSHALE		
										GRAY CLAYSHALE		
										RED CLAYSHALE		
										GRAY CLAYSHALE		
4	NQ	34.7	44.7		9.2	92	35			RED CLAYSHALE		
										RED CLAYSHALE		
5	NQ	44.7	50.8		6.1	96	45			RED AND GRAY CLAYSHALE		

AEP MT LBR LF FKA SI/GPJ AEP.GDT 7/23/15

Continued Next Page

AMERICAN ELECTRIC POWER SERVICE CORPORATION
AEP CIVIL ENGINEERING LABORATORY
 LOG OF BORING



JOB NUMBER _____

COMPANY **APPALACHIAN POWER COMPANY**

BORING NO. **B-403** DATE **7/23/15** SHEET **3** OF **12**

PROJECT **MOUNTAINEER LBR LANDFILL**

BORING START **2/5/86** BORING FINISH _____

SAMPLE NUMBER	SAMPLE	SAMPLE DEPTH IN FEET		STANDARD PENETRATION RESISTANCE BLOWS / 6"	TOTAL LENGTH RECOVERY	RQD	DEPTH IN FEET	GRAPHIC LOG	USCS	SOIL / ROCK IDENTIFICATION	WELL	DRILLER'S NOTES
		FROM	TO			%						
6	NQ	50.8	52.3		1.3	77	50			RED CLAYSHALE		
7	NQ	52.3	54.7		2.0	83						
8	NQ	54.7	64.7		10	100	55					
										GRAY CLAYSHALE		
										GRAY SANDY SHALE		
							60			GRAY CLAYSHALE		
										GRAY SANDY SHALE		
										GRAY CLAYSHALE		
9	NQ	64.7	74.7		10	100	65			GRAY SANDY SHALE		
										GRAY SANDSTONE		
										GRAY CLAYSHALE		
										GRAY SANDY SHALE		
							70			GRAY CLAYSHALE		

AEP MT LBR LF FKA SIGPJ AEP.GDT 7/23/15

Continued Next Page

AMERICAN ELECTRIC POWER SERVICE CORPORATION
AEP CIVIL ENGINEERING LABORATORY
 LOG OF BORING



JOB NUMBER _____

COMPANY **APPALACHIAN POWER COMPANY**

BORING NO. **B-403** DATE **7/23/15** SHEET **4** OF **12**

PROJECT **MOUNTAINEER LBR LANDFILL**

BORING START **2/5/86** BORING FINISH _____

SAMPLE NUMBER	SAMPLE	SAMPLE DEPTH IN FEET		STANDARD PENETRATION RESISTANCE BLOWS / 6"	TOTAL LENGTH RECOVERY	RQD	DEPTH IN FEET	GRAPHIC LOG	USCS	SOIL / ROCK IDENTIFICATION	WELL	DRILLER'S NOTES
		FROM	TO			%						
10	NQ	74.7	84.7		9.6	96	75			GRAY SANDSTONE		
							80			GRAY SANDY SHALE GRAY CLAYSHALE		
11	NQ	84.7	89.7		5.0	92	85			RED CLAYSHALE		
12	NQ	89.7	94.7		5.0	100	90			GRAY CLAYSHALE		
13	NQ	94.7	104.7		9.9	99	95					

AEP MT LBR LF FKA SI/GPJ AEP.GDT 7/23/15

Continued Next Page

AMERICAN ELECTRIC POWER SERVICE CORPORATION
AEP CIVIL ENGINEERING LABORATORY
 LOG OF BORING



JOB NUMBER _____

COMPANY **APPALACHIAN POWER COMPANY**

BORING NO. **B-403** DATE **7/23/15** SHEET **5** OF **12**

PROJECT **MOUNTAINEER LBR LANDFILL**

BORING START **2/5/86** BORING FINISH _____

SAMPLE NUMBER	SAMPLE	SAMPLE DEPTH IN FEET		STANDARD PENETRATION RESISTANCE BLOWS / 6"	TOTAL LENGTH RECOVERY	RQD	DEPTH IN FEET	GRAPHIC LOG	USCS	SOIL / ROCK IDENTIFICATION	WELL	DRILLER'S NOTES
		FROM	TO			%						
							100					
14	NQ	104.7	107.6		2.6	94	105			RED CLAYSHALE		
15	NQ	107.6	114.7		7.0	100				GRAY CLAYSHALE GRAY SANDSTONE		
							110			GRAY SILTSTONE GRAY SANDSTONE		
16	NQ	114.7	124.7		10	100	115			GRAY SILTSTONE GRAY SANDSTONE		
							120			GRAY SILTSTONE GRAY SANDSTONE		

AEP MT LBR LF FKA SI/GPJ AEP.GDT 7/23/15

Continued Next Page

AMERICAN ELECTRIC POWER SERVICE CORPORATION
AEP CIVIL ENGINEERING LABORATORY
 LOG OF BORING



JOB NUMBER _____

COMPANY **APPALACHIAN POWER COMPANY**

BORING NO. **B-403** DATE **7/23/15** SHEET **6** OF **12**

PROJECT **MOUNTAINEER LBR LANDFILL**

BORING START **2/5/86** BORING FINISH _____

SAMPLE NUMBER	SAMPLE	SAMPLE DEPTH IN FEET		STANDARD PENETRATION RESISTANCE BLOWS / 6"	TOTAL LENGTH RECOVERY	RQD	DEPTH IN FEET	GRAPHIC LOG	USCS	SOIL / ROCK IDENTIFICATION	WELL	DRILLER'S NOTES
		FROM	TO			%						
17	NQ	124.7	134.7		9.8	98	125					
							130			GRAY CLAYSHALE		
							135			GRAY SILTSTONE		
18	NQ	134.7	144.7		9.9	99	135					
							140			GRAY SANDSTONE		
19	NQ	144.7	154.7		9.9	99	145			GRAY SILTSTONE		145.6 Top of screen.
										RED CLAYSHALE		149.6 Bottom of

AEP MT LBR LF FKA SI/GPJ AEP.GDT 7/23/15

Continued Next Page

AMERICAN ELECTRIC POWER SERVICE CORPORATION
AEP CIVIL ENGINEERING LABORATORY
 LOG OF BORING



JOB NUMBER _____

COMPANY **APPALACHIAN POWER COMPANY**

BORING NO. **B-403** DATE **7/23/15** SHEET **7** OF **12**

PROJECT **MOUNTAINEER LBR LANDFILL**

BORING START **2/5/86** BORING FINISH _____

SAMPLE NUMBER	SAMPLE	SAMPLE DEPTH IN FEET		STANDARD PENETRATION RESISTANCE BLOWS / 6"	TOTAL LENGTH RECOVERY	RQD	DEPTH IN FEET	GRAPHIC LOG	USCS	SOIL / ROCK IDENTIFICATION	WELL	DRILLER'S NOTES
		FROM	TO			%						
												screen. 151.0 Bottom of gravel pack.
20	NQ	154.7	161.5		6.3	77	155			GRAY SILTSTONE		
							160			RED CLAYSHALE		
21	NQ	161.5	164.7		3.2	92						
22	NQ	164.7	174.7		10	100	165			GRAY SILTSTONE		
							170			GRAY SANDSTONE		168.9 Top of gravel pack.
										GRAY SILTSTONE		
23	NQ	174.7	184.7		9.8	97	175			GRAY CLAYSHALE RED CLAYSHALE		

AEP MT LBR LF FKA SI/GPJ AEP.GDT 7/23/15

Continued Next Page

AMERICAN ELECTRIC POWER SERVICE CORPORATION
AEP CIVIL ENGINEERING LABORATORY
 LOG OF BORING



JOB NUMBER _____

COMPANY **APPALACHIAN POWER COMPANY**

BORING NO. **B-403** DATE **7/23/15** SHEET **8** OF **12**

PROJECT **MOUNTAINEER LBR LANDFILL**

BORING START **2/5/86** BORING FINISH _____

SAMPLE NUMBER	SAMPLE	SAMPLE DEPTH IN FEET		STANDARD PENETRATION RESISTANCE BLOWS / 6"	TOTAL LENGTH RECOVERY	RQD	DEPTH IN FEET	GRAPHIC LOG	USCS	SOIL / ROCK IDENTIFICATION	WELL	DRILLER'S NOTES
		FROM	TO			%						
							180			GRAY SILTSTONE		
24	NQ	184.7	191.3		6.4	56	185			MULTI-COLORED CLAYSHALE		
25	NQ	191.3	194.7		78	78	190			RED CLAYSHALE		
26	NQ	194.7	204.7		9.9	90	195			GRAY SANDSTONE		
							200					

AEP MT LBR LF FKA SIGPJ AEP.GDT 7/23/15

Continued Next Page

AMERICAN ELECTRIC POWER SERVICE CORPORATION
AEP CIVIL ENGINEERING LABORATORY
 LOG OF BORING



JOB NUMBER _____

COMPANY **APPALACHIAN POWER COMPANY**

BORING NO. **B-403** DATE **7/23/15** SHEET **10** OF **12**

PROJECT **MOUNTAINEER LBR LANDFILL**

BORING START **2/5/86** BORING FINISH _____

SAMPLE NUMBER	SAMPLE	SAMPLE DEPTH IN FEET		STANDARD PENETRATION RESISTANCE BLOWS / 6"	TOTAL LENGTH RECOVERY	RQD	DEPTH IN FEET	GRAPHIC LOG	USCS	SOIL / ROCK IDENTIFICATION	WELL	DRILLER'S NOTES
		FROM	TO			%						
							230					
30	NQ	234.7	244.7		10	100	235					
										GRAY SANDSTONE		
							240					
31	NQ	244.7	254.7		9.8	83	245			RED AND GRAY CLAYSHALE		
										GRAY CLAYSHALE		
							250			RED CLAYSHALE		

AEP MT LBR LF FKA SI/GPJ AEP.GDT 7/23/15

Continued Next Page

AMERICAN ELECTRIC POWER SERVICE CORPORATION
AEP CIVIL ENGINEERING LABORATORY
 LOG OF BORING



JOB NUMBER _____

COMPANY **APPALACHIAN POWER COMPANY**

BORING NO. **B-403** DATE **7/23/15** SHEET **11** OF **12**

PROJECT **MOUNTAINEER LBR LANDFILL**

BORING START **2/5/86** BORING FINISH _____

SAMPLE NUMBER	SAMPLE	SAMPLE DEPTH IN FEET		STANDARD PENETRATION RESISTANCE BLOWS / 6"	TOTAL LENGTH RECOVERY		DEPTH IN FEET	GRAPHIC LOG	USCS	SOIL / ROCK IDENTIFICATION	WELL	DRILLER'S NOTES
		FROM	TO		%	RQD						
32	NQ	254.7	264.7		10	92	255					
33	NQ	264.7	274.7		9.7	97	265		GRAY SANDSTONE			
							270		GRAY SILTSTONE			
												274.0 Bottom of boring.
BOTTOM OF BORING 274.7' WELLS MW-1 AND MW-2 WERE NESTED IN A 3" DIAMETER HOLE. WELL MW-1 N.709,726.78 E.1,731,757.61 GROUND ELEVATION 854.61 TOP OF PIPE ELEVATION 856.35 LATITUDE 38 56 43.00 LONGITUDE 81 56 33.09 1.25" DIAMETER POLETHYLENE SCREEN.												

AEP MT LBR LF FKA SJ/GPJ AEP.GDT 7/23/15

Continued Next Page

AMERICAN ELECTRIC POWER SERVICE CORPORATION
AEP CIVIL ENGINEERING LABORATORY
 LOG OF BORING



JOB NUMBER _____

COMPANY **APPALACHIAN POWER COMPANY**

BORING NO. **B-403** DATE **7/23/15** SHEET **12** OF **12**

PROJECT **MOUNTAINEER LBR LANDFILL**

BORING START **2/5/86** BORING FINISH _____

SAMPLE NUMBER	SAMPLE	SAMPLE DEPTH IN FEET		STANDARD PENETRATION RESISTANCE BLOWS / 6"	TOTAL LENGTH RECOVERY	RQD	DEPTH IN FEET	GRAPHIC LOG	USCS	SOIL / ROCK IDENTIFICATION	WELL	DRILLER'S NOTES
		FROM	TO			%						
										0.75" DIAMETER SCH. 80 PVC CASING. Hole was flushed with drill water until return drill water was visually clear. A geomon type monitoring well was installed and purged until a visually clear sample was obtained. WELL MW-2 N.709,726.78 E.1,731,757.61 GROUND ELEVATION 854.61 TOP OF PIPE ELEVATION 856.35 LATITUDE 38 56 43.00 LONGITUDE 81 56 33.09 1.25 DIAMETER POLETHYLENE SCREEN. 0.75" SCH. 80 PVC RIZER Hole was flushed with drill water until return drill water was visually clear. A geomon type monitoring well was installed and purged until a visually clear sample was obtained.		

AMERICAN ELECTRIC POWER SERVICE CORPORATION
AEP CIVIL ENGINEERING LABORATORY
 LOG OF BORING



JOB NUMBER _____
 COMPANY **APPALACHIAN POWER COMPANY**
 PROJECT **MOUNTAINEER LBR LANDFILL**
 COORDINATES **N 709,984.6 E 1,728,253.0**
 GROUND ELEVATION **756.7** SYSTEM _____

BORING NO. **B-404** DATE **7/23/15** SHEET **1** OF **6**
 BORING START **3/25/86** BORING FINISH **3/26/86**
 PIEZOMETER TYPE _____ WELL TYPE _____
 HGT. RISER ABOVE GROUND _____ DIA **6"**
 DEPTH TO TOP OF WELL SCREEN _____ BOTTOM _____
 WELL DEVELOPMENT _____ BACKFILL _____
 FIELD PARTY **ROUSH/LAMBERT** RIG **B-61**

Water Level, ft	<input type="checkbox"/>	<input type="checkbox"/>	<input type="checkbox"/>
TIME			
DATE			

SAMPLE NUMBER	SAMPLE	SAMPLE DEPTH IN FEET		STANDARD PENETRATION RESISTANCE BLOWS / 6"	TOTAL LENGTH RECOVERY	RQD %	DEPTH IN FEET	GRAPHIC LOG	USCS	SOIL / ROCK IDENTIFICATION	WELL	DRILLER'S NOTES
		FROM	TO									
1	SS	3.0	4.5	2-3-3	1.33		5			BROWN CLAY with rock fragments		SEATED CASING - STARTED CORING
2	SS	8.0	8.4	50/0.1	0.1		10			BROWN SHALE sandy		
1	NQ	8.4	13.4		5.0	61				GRAY CLAYSHALE		
2	NQ	13.4	20.5		6.4	84	15					

TYPE OF CASING USED

Continued Next Page

<input checked="" type="checkbox"/>	NQ-2 ROCK CORE
<input checked="" type="checkbox"/>	6" x 3.25 HSA
	9" x 6.25 HSA
	HW CASING ADVANCER 4"
	NW CASING 3"
	SW CASING 6"
	AIR HAMMER 8"

PIEZOMETER TYPE: PT = OPEN TUBE POROUS TIP, SS = OPEN TUBE SLOTTED SCREEN, G = GEONOR, P = PNEUMATIC
 WELL TYPE: OW = OPEN TUBE SLOTTED SCREEN, GM = GEOMON

RECORDER **JCM**

AMERICAN ELECTRIC POWER SERVICE CORPORATION
AEP CIVIL ENGINEERING LABORATORY
 LOG OF BORING



JOB NUMBER _____

COMPANY **APPALACHIAN POWER COMPANY**

BORING NO. **B-404** DATE **7/23/15** SHEET **2** OF **6**

PROJECT **MOUNTAINEER LBR LANDFILL**

BORING START **3/25/86** BORING FINISH **3/26/86**

SAMPLE NUMBER	SAMPLE	SAMPLE DEPTH IN FEET		STANDARD PENETRATION RESISTANCE BLOWS / 6"	TOTAL LENGTH RECOVERY	RQD	DEPTH IN FEET	GRAPHIC LOG	USCS	SOIL / ROCK IDENTIFICATION	WELL	DRILLER'S NOTES	
		FROM	TO			%							
3	NQ	20.5	25.5		4.7	57				gray siltstone lense 22.1 to 22.6 gray siltstone lense 22.7 to 23.8			
											gray siltstone lense 24.1 to 24.4 gray siltstone lense 24.9 to 25.5 gray sandstone lense 25.5 to 26.1 gray sandstone lense 26.3 to 26.6		
4	NQ	25.5	35.5		9.6	92							
											red clayshale 31.3 to 34.8		
5	NQ	35.5	45.5		9.4	80							
											GRAY SANDSTONE GRAY CLAYSHALE		
6	NQ	45.5	54.6		8.3	78				RED CLAYSHALE			

AEP MT LBR LF FKA SI/GPJ AEP.GDT 7/23/15

Continued Next Page

AMERICAN ELECTRIC POWER SERVICE CORPORATION
AEP CIVIL ENGINEERING LABORATORY
 LOG OF BORING



JOB NUMBER _____

COMPANY **APPALACHIAN POWER COMPANY**

BORING NO. **B-404** DATE **7/23/15** SHEET **3** OF **6**

PROJECT **MOUNTAINEER LBR LANDFILL**

BORING START **3/25/86** BORING FINISH **3/26/86**

SAMPLE NUMBER	SAMPLE	SAMPLE DEPTH IN FEET		STANDARD PENETRATION RESISTANCE BLOWS / 6"	TOTAL LENGTH RECOVERY	RQD	DEPTH IN FEET	GRAPHIC LOG	USCS	SOIL / ROCK IDENTIFICATION	WELL	DRILLER'S NOTES
		FROM	TO			%						
7	NQ	54.6	55.5		0.9	46	55			GRAY CLAYSHALE		
8	NQ	55.5	65.5		10.0	91				RED CLAYSHALE GRAY CLAYSHALE		
							60			RED CLAYSHALE		
9	NQ	65.5	75.5		9.9	96	65			GRAY CLAYSHALE		
							70			MULTI-COLORED CLAYSHALE		

AEP MT LBR LF FKA SI/GPJ AEP.GDT 7/23/15

Continued Next Page

AMERICAN ELECTRIC POWER SERVICE CORPORATION
AEP CIVIL ENGINEERING LABORATORY
 LOG OF BORING



JOB NUMBER _____

COMPANY **APPALACHIAN POWER COMPANY**

BORING NO. **B-404** DATE **7/23/15** SHEET **4** OF **6**

PROJECT **MOUNTAINEER LBR LANDFILL**

BORING START **3/25/86** BORING FINISH **3/26/86**

SAMPLE NUMBER	SAMPLE	SAMPLE DEPTH IN FEET		STANDARD PENETRATION RESISTANCE BLOWS / 6"	TOTAL LENGTH RECOVERY	RQD	DEPTH IN FEET	GRAPHIC LOG	USCS	SOIL / ROCK IDENTIFICATION	WELL	DRILLER'S NOTES
		FROM	TO			%						
10	NQ	75.5	85.5		10	100	75			RED CLAYSHALE		
							80			GRAY CLAYSHALE		
										GRAY SANDSTONE		
11	NQ	85.5	94.9		9.4	100	85			GRAY SANDSTONE		
							90			GRAY CLAYSHALE		
12	NQ	95.5	104.6		8.8	57	95			RED CLAYSHALE		

AEP MT LBR LF FKA S/GPJ AEP.GDT 7/23/15

Continued Next Page

AMERICAN ELECTRIC POWER SERVICE CORPORATION
AEP CIVIL ENGINEERING LABORATORY
 LOG OF BORING



JOB NUMBER _____

COMPANY **APPALACHIAN POWER COMPANY**

BORING NO. **B-404** DATE **7/23/15** SHEET **5** OF **6**

PROJECT **MOUNTAINEER LBR LANDFILL**

BORING START **3/25/86** BORING FINISH **3/26/86**

SAMPLE NUMBER	SAMPLE	SAMPLE DEPTH IN FEET		STANDARD PENETRATION RESISTANCE BLOWS / 6"	TOTAL LENGTH RECOVERY	RQD	DEPTH IN FEET	GRAPHIC LOG	USCS	SOIL / ROCK IDENTIFICATION	WELL	DRILLER'S NOTES
		FROM	TO			%						
							100					
13	NQ	104.6	105.5		0.9	93	105					
14	NQ	105.5	115.5		9.8	89				GRAY CLAYSHALE		
							110			GRAY SILTSTONE		
15	NQ	115.5	125.5		10.0	100	115			GRAY SANDSTONE		
							120			GRAY CLAYSHALE		

AEP MT LBR LF FKA SI/GPJ AEP.GDT 7/23/15

Continued Next Page

AMERICAN ELECTRIC POWER SERVICE CORPORATION
AEP CIVIL ENGINEERING LABORATORY
 LOG OF BORING



JOB NUMBER _____

COMPANY **APPALACHIAN POWER COMPANY**

BORING NO. **B-404** DATE **7/23/15** SHEET **6** OF **6**

PROJECT **MOUNTAINEER LBR LANDFILL**

BORING START **3/25/86** BORING FINISH **3/26/86**

SAMPLE NUMBER	SAMPLE	SAMPLE DEPTH IN FEET		STANDARD PENETRATION RESISTANCE BLOWS / 6"	TOTAL LENGTH RECOVERY	RQD	DEPTH IN FEET	GRAPHIC LOG	USCS	SOIL / ROCK IDENTIFICATION	WELL	DRILLER'S NOTES
		FROM	TO			%						
16	NQ	125.5	135.0		9.5	100	125			GRAY SANDSTONE		
							130			RED AND GRAY CLAYSHALE		
							135			BOTTOM OF BORING 135.0'		STOPPED BORING AT 135.0'

AMERICAN ELECTRIC POWER SERVICE CORPORATION
AEP CIVIL ENGINEERING LABORATORY
 LOG OF BORING



JOB NUMBER _____
 COMPANY **APPALACHIAN POWER COMPANY**
 PROJECT **MOUNTAINEER LBR LANDFILL**
 COORDINATES **N 709,173.3 E 1,728,977.0**
 GROUND ELEVATION **855.6** SYSTEM _____

BORING NO. **B-405** DATE **7/23/15** SHEET **1** OF **11**
 BORING START **3/12/86** BORING FINISH **4/2/86**
 PIEZOMETER TYPE _____ WELL TYPE **GM**
 HGT. RISER ABOVE GROUND **2.0** DIA **3"**
 DEPTH TO TOP OF WELL SCREEN **143.2** BOTTOM **147.2**
 WELL DEVELOPMENT **SEE NOTES** BACKFILL **CONCRETE SAND**
 FIELD PARTY **TLS-GB** RIG **CME-75**

Water Level, ft	▽ 67.0	▼	▼
TIME			
DATE	5-2-86		

SAMPLE NUMBER	SAMPLE	SAMPLE DEPTH IN FEET		STANDARD PENETRATION RESISTANCE BLOWS / 6"	TOTAL LENGTH RECOVERY	RQD %	DEPTH IN FEET	GRAPHIC LOG	USCS	SOIL / ROCK IDENTIFICATION	WELL	DRILLER'S NOTES
		FROM	TO									
1	SS	3.2	4.7									
2	SS	7.8	8.1	50/3	.3	70	5					
3	NQ	8.1	15.3		9.7							
4	NQ	15.3	25.3		10.0	81	15					

TYPE OF CASING USED

X	NQ-2 ROCK CORE
	6" x 3.25 HSA
	9" x 6.25 HSA
	HW CASING ADVANCER 4"
	NW CASING 3"
	SW CASING 6"
	AIR HAMMER 8"

Continued Next Page

PIEZOMETER TYPE: PT = OPEN TUBE POROUS TIP, SS = OPEN TUBE SLOTTED SCREEN, G = GEONOR, P = PNEUMATIC
 WELL TYPE: OW = OPEN TUBE SLOTTED SCREEN, GM = GEOMON

RECORDER _____

AEP_Mt.LBR.LF.FKA.SI.GPJ.AEP.GDT.7/23/15

AMERICAN ELECTRIC POWER SERVICE CORPORATION
AEP CIVIL ENGINEERING LABORATORY
 LOG OF BORING



JOB NUMBER _____

COMPANY **APPALACHIAN POWER COMPANY**

BORING NO. **B-405** DATE **7/23/15** SHEET **2** OF **11**

PROJECT **MOUNTAINEER LBR LANDFILL**

BORING START **3/12/86** BORING FINISH **4/2/86**

SAMPLE NUMBER	SAMPLE	SAMPLE DEPTH IN FEET		STANDARD PENETRATION RESISTANCE BLOWS / 6"	TOTAL LENGTH RECOVERY	RQD	DEPTH IN FEET	GRAPHIC LOG	USCS	SOIL / ROCK IDENTIFICATION	WELL	DRILLER'S NOTES
		FROM	TO			%						
5	NQ	25.3	35.3		9.6	93	25			GRAY/BLUE GREEN SANDSTONE V-fine grain, well cemented 27.5 TO 29.0 Fine grain		
6	NQ	35.3	40.3		3.8		35			RED AND GRAY CLAY SHALE V-soft RED CLAY SHALE Soft		34.7 Top of seal.
7	NQ	40.3	45.3		4.1	70	40					39.3 Top of gravel pack.
8	NQ	45.3	55.3		10.0	96	45			BLUE GRAY SILTY SHALE		

AEP MT LBR LF FKA SI/GPJ AEP.GDT 7/23/15

Continued Next Page

AMERICAN ELECTRIC POWER SERVICE CORPORATION
AEP CIVIL ENGINEERING LABORATORY
 LOG OF BORING



JOB NUMBER _____

COMPANY **APPALACHIAN POWER COMPANY**

BORING NO. **B-405** DATE **7/23/15** SHEET **3** OF **11**

PROJECT **MOUNTAINEER LBR LANDFILL**

BORING START **3/12/86** BORING FINISH **4/2/86**

SAMPLE NUMBER	SAMPLE	SAMPLE DEPTH IN FEET		STANDARD PENETRATION RESISTANCE BLOWS / 6"	TOTAL LENGTH RECOVERY	RQD	DEPTH IN FEET	GRAPHIC LOG	USCS	SOIL / ROCK IDENTIFICATION	WELL	DRILLER'S NOTES
		FROM	TO			%						
							50			BLUE GRAY SANDSTONE Fine grain, well sorted.		
										BLUE GRAY CLAY SHALE Soft, broken		
										BLUE GRAY SHALEY SANDSTONE		
9	NQ	55.3	65.3		10.0	96	55					
										BROWN SANDSTONE Fine grain, well sorted vertical cracks at 59.5 to 60.0 GRAY SANDSTONE Fine grain, well sorted.		
										GRAY SILTY SHALE Soft.		
10	NQ	65.3	70.3		5.0	96	65					
										RED AND GRAY CLAY SHALE		
11	NQ	70.3	75.3		4.6		70			GRAY CLAY SHALE		

AEP MT LBR LF FKA SIGPJ AEP.GDT 7/23/15

Continued Next Page

AMERICAN ELECTRIC POWER SERVICE CORPORATION
AEP CIVIL ENGINEERING LABORATORY
 LOG OF BORING



JOB NUMBER _____

COMPANY **APPALACHIAN POWER COMPANY**

BORING NO. **B-405** DATE **7/23/15** SHEET **4** OF **11**

PROJECT **MOUNTAINEER LBR LANDFILL**

BORING START **3/12/86** BORING FINISH **4/2/86**

SAMPLE NUMBER	SAMPLE	SAMPLE DEPTH IN FEET		STANDARD PENETRATION RESISTANCE BLOWS / 6"	TOTAL LENGTH RECOVERY	RQD	DEPTH IN FEET	GRAPHIC LOG	USCS	SOIL / ROCK IDENTIFICATION	WELL	DRILLER'S NOTES
		FROM	TO			%						
							75			RED CLAY SHALE		
12	NQ	75.3	85.3		9.9		80					
13	NQ	85.3	95.3		9.8		85					
							90					
							95			GRAY SHALEY SANDSTONE		

AEP MT LBR LF FKA SI/GPJ AEP.GDT 7/23/15

Continued Next Page

AMERICAN ELECTRIC POWER SERVICE CORPORATION
AEP CIVIL ENGINEERING LABORATORY
 LOG OF BORING



JOB NUMBER _____

COMPANY **APPALACHIAN POWER COMPANY**

BORING NO. **B-405** DATE **7/23/15** SHEET **5** OF **11**

PROJECT **MOUNTAINEER LBR LANDFILL**

BORING START **3/12/86** BORING FINISH **4/2/86**

SAMPLE NUMBER	SAMPLE	SAMPLE DEPTH IN FEET		STANDARD PENETRATION RESISTANCE BLOWS / 6"	TOTAL LENGTH RECOVERY	RQD	DEPTH IN FEET	GRAPHIC LOG	USCS	SOIL / ROCK IDENTIFICATION	WELL	DRILLER'S NOTES
		FROM	TO			%						
							100			GRAY SANDSTONE		
15	NQ	105.3	115.3		96		105					
							110					
							115			GRAY CLAY SHALE GRAY SANDY SHALE With clayshale lens		
16	NQ	115.3	125.3		10.0		120					

AEP MT LBR LF FKA SI/GPJ AEP.GDT 7/23/15

Continued Next Page

AMERICAN ELECTRIC POWER SERVICE CORPORATION
AEP CIVIL ENGINEERING LABORATORY
 LOG OF BORING



JOB NUMBER _____

COMPANY **APPALACHIAN POWER COMPANY**

BORING NO. **B-405** DATE **7/23/15** SHEET **6** OF **11**

PROJECT **MOUNTAINEER LBR LANDFILL**

BORING START **3/12/86** BORING FINISH **4/2/86**

SAMPLE NUMBER	SAMPLE	SAMPLE DEPTH IN FEET		STANDARD PENETRATION RESISTANCE BLOWS / 6"	TOTAL LENGTH RECOVERY	RQD		DEPTH IN FEET	GRAPHIC LOG	USCS	SOIL / ROCK IDENTIFICATION	WELL	DRILLER'S NOTES
		FROM	TO			%	%						
								125			GRAY SANDSTONE		
17	NQ	125.3	135.3		9.8								
								130			RED AND GRAY SHALE		
											GRAY SANDSTONE Course grain.		
18	NQ	135.3	145.1		9.8	100		135			GRAY SILTSTONE		
											GRAY CLAYSHALE		
								140			GRAY SANDSTONE		
													143.2 Top of screen.
19	NQ	145.1	150.1		4.6	91		145			GRAY CLAY SHALE RED CLAY SHALE		
													147.2 Bottom of screen.

AEP MT LBR LF FKA SI/GPJ AEP.GDT 7/23/15

Continued Next Page

AMERICAN ELECTRIC POWER SERVICE CORPORATION
AEP CIVIL ENGINEERING LABORATORY
 LOG OF BORING



JOB NUMBER _____

COMPANY **APPALACHIAN POWER COMPANY**

BORING NO. **B-405** DATE **7/23/15** SHEET **7** OF **11**

PROJECT **MOUNTAINEER LBR LANDFILL**

BORING START **3/12/86** BORING FINISH **4/2/86**

SAMPLE NUMBER	SAMPLE	SAMPLE DEPTH IN FEET		STANDARD PENETRATION RESISTANCE BLOWS / 6"	TOTAL LENGTH RECOVERY	RQD	DEPTH IN FEET	GRAPHIC LOG	U S C S	SOIL / ROCK IDENTIFICATION	WELL	DRILLER'S NOTES
		FROM	TO			%						
20	NQ	150.1	155.1		5.0	83						150.4 Bottom of gravel pack.
21	NQ	155.1	165.1		10.0	100	155			GRAY CLAY SHALE RED AND GRAY CLAY SHALE Layers.		
							160					
22	NQ	165.1	175.1		10.0	100	165			GRAY SILTSTONE GRAY AND RED CLAY SHALE Layers.		
							170			MULTI-COLORED CLAY SHALE		
23	NQ	175.1	185.1		10.0	100	175					

AEP MT LBR LF FKA SI/GPJ AEP.GDT 7/23/15

Continued Next Page

AMERICAN ELECTRIC POWER SERVICE CORPORATION
AEP CIVIL ENGINEERING LABORATORY
 LOG OF BORING



JOB NUMBER _____

COMPANY **APPALACHIAN POWER COMPANY**

BORING NO. **B-405** DATE **7/23/15** SHEET **8** OF **11**

PROJECT **MOUNTAINEER LBR LANDFILL**

BORING START **3/12/86** BORING FINISH **4/2/86**

SAMPLE NUMBER	SAMPLE	SAMPLE DEPTH IN FEET		STANDARD PENETRATION RESISTANCE BLOWS / 6"	TOTAL LENGTH RECOVERY	RQD	DEPTH IN FEET	GRAPHIC LOG	U S C S	SOIL / ROCK IDENTIFICATION	WELL	DRILLER'S NOTES
		FROM	TO			%						
							180			GRAY CLAY SHALE		
							185			GRAY SANDSTONE		
24	NQ	185.1	195.1		9.8	98	185					
							190					
25	NQ	195.1	205.1		10.0	87	195					
							200			GRAY AND GRAY CLAY SHALE		

AEP MT LBR LF FKA SJ/GPJ AEP.GDT 7/23/15

Continued Next Page

AMERICAN ELECTRIC POWER SERVICE CORPORATION
AEP CIVIL ENGINEERING LABORATORY
 LOG OF BORING



JOB NUMBER _____

COMPANY **APPALACHIAN POWER COMPANY**

BORING NO. **B-405** DATE **7/23/15** SHEET **9** OF **11**

PROJECT **MOUNTAINEER LBR LANDFILL**

BORING START **3/12/86** BORING FINISH **4/2/86**

SAMPLE NUMBER	SAMPLE	SAMPLE DEPTH IN FEET		STANDARD PENETRATION RESISTANCE BLOWS / 6"	TOTAL LENGTH RECOVERY	RQD	DEPTH IN FEET	GRAPHIC LOG	USCS	SOIL / ROCK IDENTIFICATION	WELL	DRILLER'S NOTES
		FROM	TO			%						
26	NQ	205.1	215.1		10.0	100	205					
							210		GRAY SANDY SHALE			
									GRAY SILTSTONE			
									GRAY SANDY SHALE			
27	NQ	215.1	225.1		10.0	100	215					
									GRAY CLAY SHALE			
							220		GRAY SANDSTONE			
28	NQ	225.1	235.1		9.7	93	225					
									GRAY SILTSTONE			
								GRAY SANDSTONE				

AEP_Mt.LBR.LF.FKA.SI.GPJ.AEP.GDT.7/23/15

Continued Next Page

AMERICAN ELECTRIC POWER SERVICE CORPORATION
AEP CIVIL ENGINEERING LABORATORY
 LOG OF BORING



JOB NUMBER _____

COMPANY **APPALACHIAN POWER COMPANY**

BORING NO. **B-405** DATE **7/23/15** SHEET **10** OF **11**

PROJECT **MOUNTAINEER LBR LANDFILL**

BORING START **3/12/86** BORING FINISH **4/2/86**

SAMPLE NUMBER	SAMPLE	SAMPLE DEPTH IN FEET		STANDARD PENETRATION RESISTANCE BLOWS / 6"	TOTAL LENGTH RECOVERY	RQD	DEPTH IN FEET	GRAPHIC LOG	USCS	SOIL / ROCK IDENTIFICATION	WELL	DRILLER'S NOTES
		FROM	TO			%						
							230			GRAY SILTSTONE		
										GRAY SANDSTONE		
										GRAY SILTSTONE		
										RED AND GRAY CLAY SHALE		
29	NQ	235.1	245.1		10.0	36	235					
							240					
							245					
30	NQ	245.1	255.1		10.0	100	245			GRAY SILTSTONE		
										GRAY SANDSTONE		
							250			GRAY SILTSTONE		
										GRAY SANDSTONE		
										GRAY SILTSTONE		
										GRAY CLAYSHALE		
										GRAY SANDSTONE		
										GRAY SILTSTONE		
										GRAY SANDSTONE		

AEP MT LBR LF FKA SI/GPJ AEP.GDT 7/23/15

Continued Next Page

AMERICAN ELECTRIC POWER SERVICE CORPORATION
AEP CIVIL ENGINEERING LABORATORY
 LOG OF BORING



JOB NUMBER _____

COMPANY **APPALACHIAN POWER COMPANY**

BORING NO. **B-405** DATE **7/23/15** SHEET **11** OF **11**

PROJECT **MOUNTAINEER LBR LANDFILL**

BORING START **3/12/86** BORING FINISH **4/2/86**

SAMPLE NUMBER	SAMPLE	SAMPLE DEPTH IN FEET		STANDARD PENETRATION RESISTANCE BLOWS / 6"	TOTAL LENGTH RECOVERY	RQD	DEPTH IN FEET	GRAPHIC LOG	USCS	SOIL / ROCK IDENTIFICATION	WELL	DRILLER'S NOTES
		FROM	TO			%						
31	NQ	255.1	260.1		5.0	100	255			GRAY SILTSTONE		
										SANDSTONE		
										GRAY SILTSTONE		
										GRAY SANDSTONE		
							260			GRAY CLAY SHALE		
										LATITUDE 38 56 37.25 LONGITUDE 81 57 09.95 WELL DEVELOPMENT Boring was flushed with drill water until drill water return was visually clean and a geomon type well was installed and purged until a visually clean sample was obtained. WELL MATERIAL 1.25" diameter polyethylene screen. 0.75" diameter sch. 80 pvc casing		260.1 Bottom of boring.

AMERICAN ELECTRIC POWER SERVICE CORPORATION
AEP CIVIL ENGINEERING LABORATORY
 LOG OF BORING



JOB NUMBER _____
 COMPANY **APPALACHIAN POWER COMPANY**
 PROJECT **MOUNTAINEER LBR LANDFILL**
 COORDINATES **N 710,550.0 E 1,730,365.0**
 GROUND ELEVATION **680.0** SYSTEM _____

BORING NO. **BFA-1** DATE **7/23/15** SHEET **1** OF **9**
 BORING START _____ BORING FINISH **8/25/92**
 PIEZOMETER TYPE _____ WELL TYPE _____
 HGT. RISER ABOVE GROUND _____ DIA **6"**
 DEPTH TO TOP OF WELL SCREEN _____ BOTTOM _____
 WELL DEVELOPMENT _____ BACKFILL _____
 FIELD PARTY _____ RIG _____

Water Level, ft	▽	▼	▼
TIME			
DATE			

SAMPLE NUMBER	SAMPLE	SAMPLE DEPTH IN FEET		STANDARD PENETRATION RESISTANCE BLOWS / 6"	TOTAL LENGTH RECOVERY	RQD %	DEPTH IN FEET	GRAPHIC LOG	USCS	SOIL / ROCK IDENTIFICATION	WELL	DRILLER'S NOTES
		FROM	TO									
							5			OVERBURDEN CLAY AND SANDSTONE		
							10					
1	NQ	14.0	25.1		11.1	65	15			SANDSTONE AND CLAY INTERBEDDED		
										GRAY SANDSTONE fine to medium grained, two 45 degree shears		

TYPE OF CASING USED

	NQ-2 ROCK CORE	
	6" x 3.25 HSA	
	9" x 6.25 HSA	
	HW CASING ADVANCER	4"
	NW CASING	3"
	SW CASING	6"
	AIR HAMMER	8"

Continued Next Page

PIEZOMETER TYPE: PT = OPEN TUBE POROUS TIP, SS = OPEN TUBE SLOTTED SCREEN, G = GEONOR, P = PNEUMATIC
 WELL TYPE: OW = OPEN TUBE SLOTTED SCREEN, GM = GEOMON

RECORDER _____

AMERICAN ELECTRIC POWER SERVICE CORPORATION
AEP CIVIL ENGINEERING LABORATORY
 LOG OF BORING



JOB NUMBER _____

COMPANY **APPALACHIAN POWER COMPANY**

BORING NO. **BFA-1** DATE **7/23/15** SHEET **2** OF **9**

PROJECT **MOUNTAINEER LBR LANDFILL**

BORING START _____ BORING FINISH **8/25/92**

SAMPLE NUMBER	SAMPLE	SAMPLE DEPTH IN FEET		STANDARD PENETRATION RESISTANCE BLOWS / 6"	TOTAL LENGTH RECOVERY	RQD	DEPTH IN FEET	GRAPHIC LOG	U S C S	SOIL / ROCK IDENTIFICATION	WELL	DRILLER'S NOTES
		FROM	TO			%						
2	NQ	25.1	35.1		10	27	25			MOTTLED GRAY AND MAROON CLAYSTONE badly broken in places, core loss 0.5'		
							30			MAROON CLAYSTONE badly broken in places, includes core loss 1.30'		
3	NQ	35.1	45.1		10	81	35			MAROON CLAYSTONE badly broken in places, includes 1.0' of core loss		
										GREENISH GRAY CLAYSTONE sandy		
										MOTTLED GREEN AND MAROON CLAYSTONE		
							40			GREENISH GRAY CLAYSTONE sandy in places		
4	NQ	45.1	55.1		10	63	45			GREENISH GRAY SANDSTONE with shale laminations		

AEP MT LBR LF FKA SI/GPJ AEP.GDT 7/23/15

Continued Next Page

AMERICAN ELECTRIC POWER SERVICE CORPORATION
AEP CIVIL ENGINEERING LABORATORY
 LOG OF BORING



JOB NUMBER _____

COMPANY **APPALACHIAN POWER COMPANY**

BORING NO. **BFA-1** DATE **7/23/15** SHEET **3** OF **9**

PROJECT **MOUNTAINEER LBR LANDFILL**

BORING START _____ BORING FINISH **8/25/92**

SAMPLE NUMBER	SAMPLE	SAMPLE DEPTH IN FEET		STANDARD PENETRATION RESISTANCE BLOWS / 6"	TOTAL LENGTH RECOVERY	RQD	DEPTH IN FEET	GRAPHIC LOG	USCS	SOIL / ROCK IDENTIFICATION	WELL	DRILLER'S NOTES
		FROM	TO			%						
							50			GREENISH GRAY CLAYSTONE few interbeds of sandstone, badly broken		
										GREENISH GRAY CLAYSTONE		
										GREENISH GRAY SANDSTONE medium grained, few shale laminations at top		
5	NQ	55.1	65.1		10	81	55			GREENISH GRAY SANDSTONE medium grained		
										CLAYEY SANDSTONE medium grained		
							60			GREENISH GRAY SANDSTONE medium grained		
										GREENISH GRAY CLAYSTONE soft		
										GREENISH GRAY SANDSTONE medium to fine grained		
										VARIGATED MAROON AND GREENISH GRAY CLAYSTONE		
6	NQ	65.1	75.1		10	33	65			MAROON VAREGATED WITH GREEN CLAYSTONE broken		
										BLACK CLAY hard, carbonaceous		
							70			DK. GRAY UNDERCLAY soft, coaly lenses, includes 1.70' of core loss		

AEP MT LBR LF FKA SJGJ AEP.GDT 7/23/15

Continued Next Page

AMERICAN ELECTRIC POWER SERVICE CORPORATION
AEP CIVIL ENGINEERING LABORATORY
 LOG OF BORING



JOB NUMBER _____

COMPANY **APPALACHIAN POWER COMPANY**

BORING NO. **BFA-1** DATE **7/23/15** SHEET **4** OF **9**

PROJECT **MOUNTAINEER LBR LANDFILL**

BORING START _____ BORING FINISH **8/25/92**

SAMPLE NUMBER	SAMPLE	SAMPLE DEPTH IN FEET		STANDARD PENETRATION RESISTANCE BLOWS / 6"	TOTAL LENGTH RECOVERY	RQD	DEPTH IN FEET	GRAPHIC LOG	USCS	SOIL / ROCK IDENTIFICATION	WELL	DRILLER'S NOTES
		FROM	TO			%						
							75			MAROON CLAYSTONE soft, broken		
7	NQ	75.1	85.1		10	85				MAROON, MOTTLED GREEN CLAYSTONE broken at base		
							80			GREEN CLAYSTONE shaley, sandy in places, mottled cream-colored blebs		
										GREEN SANDSTONE medium grained		
							85			GREEN CLAYSTONE sandy		
8	NQ	85.1	95.1		10	85				GREEN CLAYSTONE shaley, cream-colored blebs		
							90			DK. GREENISH GRAY CLAYSTONE sandy		
										MAROON MOTTLED WITH GREEN CLAYSTONE sandy		
9	NQ	95.1	105.1		10	52	95			GREEN MOTTLED WITH MAROON CLAYSTONE sandy		

AEP MT LBR LF FKA SI/GPJ AEP.GDT 7/23/15

Continued Next Page

AMERICAN ELECTRIC POWER SERVICE CORPORATION
AEP CIVIL ENGINEERING LABORATORY
 LOG OF BORING



JOB NUMBER _____

COMPANY **APPALACHIAN POWER COMPANY**

BORING NO. **BFA-1** DATE **7/23/15** SHEET **5** OF **9**

PROJECT **MOUNTAINEER LBR LANDFILL**

BORING START _____ BORING FINISH **8/25/92**

SAMPLE NUMBER	SAMPLE	SAMPLE DEPTH IN FEET		STANDARD PENETRATION RESISTANCE BLOWS / 6"	TOTAL LENGTH RECOVERY	RQD	DEPTH IN FEET	GRAPHIC LOG	USCS	SOIL / ROCK IDENTIFICATION	WELL	DRILLER'S NOTES
		FROM	TO			%						
							100			MAROON WITH SOME GREEN MOTTLING CLAYSTONE badly broken in lower half		
							105			GREEN CLAYSTONE soft		
10	NQ	105.1	110.1		5	43	105			MAROON WITH GREEN MOTTLING CLAYSTONE badly broken, includes 2.0' of core loss - core barrel blocked		
							110			GREEN CLAYSTONE broken		
							115			GREEN SHALE sandy GREEN GRAY SANDSTONE fine grained, shaley		
11	NQ	115.1	125.1		10	96	115			GREEN SANDSTONE fine grained		
							120			GREEN SANDSTONE medium grained		
										GREEN SANDSTONE medium to coarse grained		

AEP MT LBR LF FKA SI/GPJ AEP.GDT 7/23/15

Continued Next Page

AMERICAN ELECTRIC POWER SERVICE CORPORATION
AEP CIVIL ENGINEERING LABORATORY
 LOG OF BORING



JOB NUMBER _____

COMPANY **APPALACHIAN POWER COMPANY**

BORING NO. **BFA-1** DATE **7/23/15** SHEET **6** OF **9**

PROJECT **MOUNTAINEER LBR LANDFILL**

BORING START _____ BORING FINISH **8/25/92**

SAMPLE NUMBER	SAMPLE	SAMPLE DEPTH IN FEET		STANDARD PENETRATION RESISTANCE BLOWS / 6"	TOTAL LENGTH RECOVERY	RQD	DEPTH IN FEET	GRAPHIC LOG	USCS	SOIL / ROCK IDENTIFICATION	WELL	DRILLER'S NOTES	
		FROM	TO			%							
12	NQ	125.1	135.1		10	100	125			GREEN WITH BLACK MICACEOUS PARTINGS, SANDSTONE coarse grained			
							130						
13	NQ	135.1	145.1		10	97	135			GREEN SANDSTONE coarse to very coarse grained, micaceous			
							140			GREEN SANDSTONE coarse to very coarse grained, green, micaceous			
										DK. GRAY SANDSTONE fine grained			
										DK. GREENISH GRAY CLAYSTONE			
										DK. GRAY SHALE clayey			
14	NQ	145.1	155.1		10	98	145			GRAY CLAY soft			
										GRAY SHALE solid			
										GREENISH GRAY SANDSTONE coarse to very coarse, very competent, few granules of white quartz			

AEP MT LBR LF FKA SJ/GPJ AEP.GDT 7/23/15

Continued Next Page

AMERICAN ELECTRIC POWER SERVICE CORPORATION
AEP CIVIL ENGINEERING LABORATORY
 LOG OF BORING



JOB NUMBER _____

COMPANY **APPALACHIAN POWER COMPANY**

BORING NO. **BFA-1** DATE **7/23/15** SHEET **7** OF **9**

PROJECT **MOUNTAINEER LBR LANDFILL**

BORING START _____ BORING FINISH **8/25/92**

SAMPLE NUMBER	SAMPLE	SAMPLE DEPTH IN FEET		STANDARD PENETRATION RESISTANCE BLOWS / 6"	TOTAL LENGTH RECOVERY	RQD	DEPTH IN FEET	GRAPHIC LOG	USCS	SOIL / ROCK IDENTIFICATION	WELL	DRILLER'S NOTES
		FROM	TO			%						
							155			GREENISH GRAY SANDSTONE very coarse grained, few granules of white quartz, very competent		
15	NQ	155.1	165.1		10	100	160					
							165			SANDSTONE very coarse grained, few granules of white quartz, very competent		
16	NQ	165.1	175.1		10	100	170					
							175			GREENISH GRAY SANDSTONE very coarse grained, micaceous		
17	NQ	175.1	185.1		10	100						

AEP MT LBR LF FKA SI/GPJ AEP.GDT 7/23/15

Continued Next Page

AMERICAN ELECTRIC POWER SERVICE CORPORATION
AEP CIVIL ENGINEERING LABORATORY
 LOG OF BORING



JOB NUMBER _____

COMPANY **APPALACHIAN POWER COMPANY**

BORING NO. **BFA-1** DATE **7/23/15** SHEET **8** OF **9**

PROJECT **MOUNTAINEER LBR LANDFILL**

BORING START _____ BORING FINISH **8/25/92**

SAMPLE NUMBER	SAMPLE	SAMPLE DEPTH IN FEET		STANDARD PENETRATION RESISTANCE BLOWS / 6"	TOTAL LENGTH RECOVERY	RQD	DEPTH IN FEET	GRAPHIC LOG	USCS	SOIL / ROCK IDENTIFICATION	WELL	DRILLER'S NOTES
		FROM	TO			%						
										DK. GRAY SANDSTONE medium grained GREENISH GRAY SANDSTONE very coarse grained		
							180			DK. GREENISH GRAY SANDSTONE with black micaceous partings, medium to coarse grained		
18	NQ	185.1	195.1		10	100	185			GREENISH GRAY SANDSTONE medium to coarse grained, with black micaceous partings		
										GREENISH GRAY SANDSTONE very coarse grained		
							190					
							195			GREENISH GRAY SANDSTONE coarse grained CORE LOSS-TOOLS SANDED IN SANDSTONE WITH INTERBEDDED SHALE GREENISH GRAY SANDSTONE coarse grained, shale breccia at base GRAY SHALE DK. GRAY SHALE clayey and broken at top		
19	NQ	195.1	205.2		10.10	60						
							200			DK. GRAY SHALE pyrite inclusions		

AEP MT LBR LF FKA SJ/GPJ AEP.GDT 7/23/15

Continued Next Page

AMERICAN ELECTRIC POWER SERVICE CORPORATION
AEP CIVIL ENGINEERING LABORATORY
 LOG OF BORING



JOB NUMBER _____

COMPANY **APPALACHIAN POWER COMPANY**

BORING NO. **BFA-1** DATE **7/23/15** SHEET **9** OF **9**

PROJECT **MOUNTAINEER LBR LANDFILL**

BORING START _____ BORING FINISH **8/25/92**

SAMPLE NUMBER	SAMPLE	SAMPLE DEPTH IN FEET		STANDARD PENETRATION RESISTANCE BLOWS / 6"	TOTAL LENGTH RECOVERY	RQD	DEPTH IN FEET	GRAPHIC LOG	USCS	SOIL / ROCK IDENTIFICATION	WELL	DRILLER'S NOTES
		FROM	TO			%						
							205			CORE LOSS-COAL DK. GRAY SHALE		
20	NQ	205.2	212.0		6.8	0				DK. GRAY SHALE		
							210			CORE BED AS FOLLOWS bone coal, hard, somewhat bony bone coal, hard, somewhat bony coal, bright, hard coal, bright, thick pyrite lense near base coal, bright with sporadic pyrite, badly crushed coal, bright, thick, pyrite lense near base		
21	NQ	212.0	216.1		4.10	78				GRAY SHALE clayey GRAY SHALE clayey GRAY SHALE sandy with sandstone laminations		
							215			GRAY SHALE clayey, broken BOTTOM OF BORING 216.1'		



AEP 1992, 2006, 2008

Boring Logs

**MW-05 to MW-10, MW-12 to
MW-21, MW-43, MW-44**

AMERICAN ELECTRIC POWER SERVICE CORPORATION
AEP CIVIL ENGINEERING LABORATORY
 LOG OF BORING



JOB NUMBER _____
 COMPANY **APPALACHIAN POWER COMPANY**
 PROJECT **MOUNTAINEER LBR LANDFILL**
 COORDINATES **N 711,462.7 E 1,728,597.8**
 GROUND ELEVATION **788.9** SYSTEM _____

BORING NO. **MW-05** DATE **7/23/15** SHEET **1** OF **4**
 BORING START **6/16/92** BORING FINISH **6/23/92**
 PIEZOMETER TYPE _____ WELL TYPE **GM**
 HGT. RISER ABOVE GROUND **2.52** DIA **1.0**
 DEPTH TO TOP OF WELL SCREEN **46.8** BOTTOM **48.8**
 WELL DEVELOPMENT **SEE NOTES** BACKFILL **VOLCLAY GROUT**
 FIELD PARTY **TJH-RLY** RIG **CME-75**

Water Level, ft	▽ 33.9	▼	▼
TIME	0715		
DATE	6-17-92		

SAMPLE NUMBER	SAMPLE	SAMPLE DEPTH IN FEET		STANDARD PENETRATION RESISTANCE BLOWS / 6"	TOTAL LENGTH RECOVERY	RQD %	DEPTH IN FEET	GRAPHIC LOG	USCS	SOIL / ROCK IDENTIFICATION	WELL	DRILLER'S NOTES
		FROM	TO									
1	SS	2.3	3.8	4-5-6	.8					RED CLAY		
2	SS	7.3	7.8	50/5	.5		5			BROWN SANDY ROCK FRAGMENT		
1	NQ-2	8.7	12.6		3.8	27				RED AND BROWN SHALE		
2	NQ-2	12.6	14.8		1.5	0				LIGHT BROWN SANDSTONE		
3	NQ-2	14.8	24.8		6.8	32	15			LIGHT BROWN SANDY SHALE		
										RED SHALE		

TYPE OF CASING USED

<input checked="" type="checkbox"/>	NQ-2 ROCK CORE
<input checked="" type="checkbox"/>	6" x 3.25 HSA
	9" x 6.25 HSA
	HW CASING ADVANCER 4"
	NW CASING 3"
	SW CASING 6"
	AIR HAMMER 8"

Continued Next Page

PIEZOMETER TYPE: PT = OPEN TUBE POROUS TIP, SS = OPEN TUBE SLOTTED SCREEN, G = GEONOR, P = PNEUMATIC
 WELL TYPE: OW = OPEN TUBE SLOTTED SCREEN, GM = GEOMON

RECORDER _____

AMERICAN ELECTRIC POWER SERVICE CORPORATION
AEP CIVIL ENGINEERING LABORATORY
 LOG OF BORING



JOB NUMBER _____

COMPANY **APPALACHIAN POWER COMPANY**

BORING NO. **MW-05** DATE **7/23/15** SHEET **2** OF **4**

PROJECT **MOUNTAINEER LBR LANDFILL**

BORING START **6/16/92** BORING FINISH **6/23/92**

SAMPLE NUMBER	SAMPLE	SAMPLE DEPTH IN FEET		STANDARD PENETRATION RESISTANCE BLOWS / 6"	TOTAL LENGTH RECOVERY	RQD	DEPTH IN FEET	GRAPHIC LOG	USCS	SOIL / ROCK IDENTIFICATION	WELL	DRILLER'S NOTES
		FROM	TO			%						
4	NQ-2	24.8	34.8		7.8	32	25					24.3 Top of bentonite seal.
							30			GRAY SHALE		29.2 Top of gravel pack.
5	NQ-2	34.8	44.8		10.0	67	35			GRAY SHALE with oxidation throughout		
							40					
							45			GRAY SANDSTONE		
6	NQ-2	44.8	49.4		3.6	74	45					

AEP MT LBR LF FKA SI/GPJ AEP.GDT 7/23/15

Continued Next Page

AMERICAN ELECTRIC POWER SERVICE CORPORATION
AEP CIVIL ENGINEERING LABORATORY
 LOG OF BORING



JOB NUMBER _____

COMPANY **APPALACHIAN POWER COMPANY**

BORING NO. **MW-05** DATE **7/23/15** SHEET **3** OF **4**

PROJECT **MOUNTAINEER LBR LANDFILL**

BORING START **6/16/92** BORING FINISH **6/23/92**

SAMPLE NUMBER	SAMPLE	SAMPLE DEPTH IN FEET		STANDARD PENETRATION RESISTANCE BLOWS / 6"	TOTAL LENGTH RECOVERY	RQD	DEPTH IN FEET	GRAPHIC LOG	USCS	SOIL / ROCK IDENTIFICATION	WELL	DRILLER'S NOTES
		FROM	TO			%						
7	NQ-2	49.4	54.8		5.4	90	50			GRAY SHALE RED SHALE RED SHALE		46.8 Top of screen. 48.8 Bottom of screen.
8	NQ-2	54.8	64.8		10.0	95	55			GRAY SHALE hard		50.2 Bottom of gravel pack.
9	NQ-2	64.8	74.8		10.0	100	65					

AEP MT LBR LF FKA SJ/GPJ AEP.GDT 7/23/15

Continued Next Page

AMERICAN ELECTRIC POWER SERVICE CORPORATION
AEP CIVIL ENGINEERING LABORATORY
 LOG OF BORING



JOB NUMBER _____

COMPANY **APPALACHIAN POWER COMPANY**

BORING NO. **MW-05** DATE **7/23/15** SHEET **4** OF **4**

PROJECT **MOUNTAINEER LBR LANDFILL**

BORING START **6/16/92** BORING FINISH **6/23/92**

SAMPLE NUMBER	SAMPLE	SAMPLE DEPTH IN FEET		STANDARD PENETRATION RESISTANCE BLOWS / 6"	TOTAL LENGTH RECOVERY	RQD	DEPTH IN FEET	GRAPHIC LOG	USCS	SOIL / ROCK IDENTIFICATION	WELL	DRILLER'S NOTES
		FROM	TO			%						
10	NQ-2	74.8	83.5		8.7	45	75					
							80			RED SHALE soft		
11	NQ-2	83.5	84.8		.8	0						
12	NQ-2	84.8	89.8		5.0	100	85			GRAY SHALE		
		89.9										
												90.0 Bottom of boring.
										Well development Hole was flushed with drill water until return water appered visually clear.Geomon type monitoring well installed and purged untill a visually clear sample was obtained. WELL MATERIAL 1.25" Diameter 20 slot screen, 1" sch. 80 pvc casing.		

AMERICAN ELECTRIC POWER SERVICE CORPORATION
AEP CIVIL ENGINEERING LABORATORY
 LOG OF BORING



JOB NUMBER _____
 COMPANY **APPALACHIAN POWER COMPANY**
 PROJECT **MOUNTAINEER LBR LANDFILL**
 COORDINATES **N 712,003.9 E 1,729,676.1**
 GROUND ELEVATION **799.2** SYSTEM _____

BORING NO. **MW-06** DATE **7/23/15** SHEET **1** OF **6**
 BORING START **7/2/92** BORING FINISH **7/16/92**
 PIEZOMETER TYPE _____ WELL TYPE **OW**
 HGT. RISER ABOVE GROUND **1.8** DIA **2.0**
 DEPTH TO TOP OF WELL SCREEN **125.8** BOTTOM **134.8**
 WELL DEVELOPMENT **SEE NOTES** BACKFILL **VOLCLAY GROUT**
 FIELD PARTY **TJH-RLY** RIG **CME-75**

Water Level, ft	▽ 17.5	▼	▼
TIME	0720		
DATE	6-3-92		

SAMPLE NUMBER	SAMPLE	SAMPLE DEPTH IN FEET		STANDARD PENETRATION RESISTANCE BLOWS / 6"	TOTAL LENGTH RECOVERY	RQD %	DEPTH IN FEET	GRAPHIC LOG	USCS	SOIL / ROCK IDENTIFICATION	WELL	DRILLER'S NOTES
		FROM	TO									
1	NQ	18.7	24.7		3.4	20				BROWN CLAY		Reamed hole to 6" and installed well.
										RED CLAY SHALE soft		

TYPE OF CASING USED

<input checked="" type="checkbox"/>	NQ-2 ROCK CORE
<input checked="" type="checkbox"/>	6" x 3.25 HSA
	9" x 6.25 HSA
	HW CASING ADVANCER 4"
	NW CASING 3"
<input checked="" type="checkbox"/>	SW CASING 6"
	AIR HAMMER 8"

Continued Next Page

PIEZOMETER TYPE: PT = OPEN TUBE POROUS TIP, SS = OPEN TUBE SLOTTED SCREEN, G = GEONOR, P = PNEUMATIC
 WELL TYPE: OW = OPEN TUBE SLOTTED SCREEN, GM = GEOMON

RECORDER _____

AEP_Mt.LBR.LF.FKA.SI.GPJ.AEP.GDT.7/23/15

AMERICAN ELECTRIC POWER SERVICE CORPORATION
AEP CIVIL ENGINEERING LABORATORY
 LOG OF BORING



JOB NUMBER _____

COMPANY **APPALACHIAN POWER COMPANY**

BORING NO. **MW-06** DATE **7/23/15** SHEET **2** OF **6**

PROJECT **MOUNTAINEER LBR LANDFILL**

BORING START **7/2/92** BORING FINISH **7/16/92**

SAMPLE NUMBER	SAMPLE	SAMPLE DEPTH IN FEET		STANDARD PENETRATION RESISTANCE BLOWS / 6"	TOTAL LENGTH RECOVERY	RQD	DEPTH IN FEET	GRAPHIC LOG	USCS	SOIL / ROCK IDENTIFICATION	WELL	DRILLER'S NOTES
		FROM	TO			%						
2	NQ	24.7	34.7		10.0	47	25			GRAY SHALE soft		
3	NQ	34.7	40.0		5.3	94	35			GRAY SANDSTONE hard		
4	NQ	40.0	45.0		5.0	100	40					
5	NQ	45.0	55.0		10.0	78	45					

AEP MT LBR LF FKA SI/GPJ AEP.GDT 7/23/15

Continued Next Page

AMERICAN ELECTRIC POWER SERVICE CORPORATION
AEP CIVIL ENGINEERING LABORATORY
 LOG OF BORING



JOB NUMBER _____

COMPANY **APPALACHIAN POWER COMPANY**

BORING NO. **MW-06** DATE **7/23/15** SHEET **3** OF **6**

PROJECT **MOUNTAINEER LBR LANDFILL**

BORING START **7/2/92** BORING FINISH **7/16/92**

SAMPLE NUMBER	SAMPLE	SAMPLE DEPTH IN FEET		STANDARD PENETRATION RESISTANCE BLOWS / 6"	TOTAL LENGTH RECOVERY	RQD	DEPTH IN FEET	GRAPHIC LOG	USCS	SOIL / ROCK IDENTIFICATION	WELL	DRILLER'S NOTES
		FROM	TO			%						
							50					
6	NQ	55.0	65.0		9.7	74	55			GRAY SHALE hard		
							60					
7	NQ	65.0	74.7		9.3	93	65			GRAY SANDSTONE		
							70					

AEP MT LBR LF FKA SJ/GPJ AEP.GDT 7/23/15

Continued Next Page

AMERICAN ELECTRIC POWER SERVICE CORPORATION
AEP CIVIL ENGINEERING LABORATORY
 LOG OF BORING



JOB NUMBER _____

COMPANY **APPALACHIAN POWER COMPANY**

BORING NO. **MW-06** DATE **7/23/15** SHEET **4** OF **6**

PROJECT **MOUNTAINEER LBR LANDFILL**

BORING START **7/2/92** BORING FINISH **7/16/92**

SAMPLE NUMBER	SAMPLE	SAMPLE DEPTH IN FEET		STANDARD PENETRATION RESISTANCE BLOWS / 6"	TOTAL LENGTH RECOVERY	RQD	DEPTH IN FEET	GRAPHIC LOG	USCS	SOIL / ROCK IDENTIFICATION	WELL	DRILLER'S NOTES
		FROM	TO			%						
8	NQ	74.7	84.7		10.0	94	75			RED SHALE GRAY SHALE		
							80					
9	NQ	84.7	90.0		5.0	65	85			GRAY SHALE hard with red lens GRAY SANDSTONE RED SHALE with high angle fracture		
							90					
10	NQ	90.0	95.0		4.5	35	90					
							95			GRAY SHALE hard GRAY SHALEY SANDSTONE hard		

AEP_Mt.LBR.LF.FKA.SI.GPJ.AEP.GDT.7/23/15

Continued Next Page

AMERICAN ELECTRIC POWER SERVICE CORPORATION
AEP CIVIL ENGINEERING LABORATORY
 LOG OF BORING



JOB NUMBER _____

COMPANY **APPALACHIAN POWER COMPANY**

BORING NO. **MW-06** DATE **7/23/15** SHEET **5** OF **6**

PROJECT **MOUNTAINEER LBR LANDFILL**

BORING START **7/2/92** BORING FINISH **7/16/92**

SAMPLE NUMBER	SAMPLE	SAMPLE DEPTH IN FEET		STANDARD PENETRATION RESISTANCE BLOWS / 6"	TOTAL LENGTH RECOVERY	RQD	DEPTH IN FEET	GRAPHIC LOG	USCS	SOIL / ROCK IDENTIFICATION	WELL	DRILLER'S NOTES
		FROM	TO			%						
							100			RED SHALE		
										GRAY SHALEY SANDSTONE		
12	NQ	105.0	115.0		10.0	82	105			GRAY SHALE hard		
										RED SHALE		
										GRAY SHALE hard		
							110					
13	NQ	115.0	123.7		8.3	53	115			RED SHALE WITH HIGH ANGLE FRACTURE		
							120					

119.2 Top of bentonite seal.

Continued Next Page

AMERICAN ELECTRIC POWER SERVICE CORPORATION
AEP CIVIL ENGINEERING LABORATORY
 LOG OF BORING



JOB NUMBER _____

COMPANY **APPALACHIAN POWER COMPANY**

BORING NO. **MW-06** DATE **7/23/15** SHEET **6** OF **6**

PROJECT **MOUNTAINEER LBR LANDFILL**

BORING START **7/2/92** BORING FINISH **7/16/92**

SAMPLE NUMBER	SAMPLE	SAMPLE DEPTH IN FEET		STANDARD PENETRATION RESISTANCE BLOWS / 6"	TOTAL LENGTH RECOVERY	RQD	DEPTH IN FEET	GRAPHIC LOG	USCS	SOIL / ROCK IDENTIFICATION	WELL	DRILLER'S NOTES
		FROM	TO			%						
14	NQ	123.7	125.0		1.3	26	125					
15	NQ	125.0	134.3		9.3	97	125			GRAY SHALE GRAY SHALEY SANDSTONE		124.5 Top of gravel pack. 125.8 Top of screen.
							130			GRAY SANDSTONE hard		
16	NQ	134.3	135.0		.6	66	135					134.8 Bottom of screen.
17	NQ	135.0	140.0		5.0		135			RED/GRAY SHALE		137.0 Bottom of screen.
		140.0					140					140.0 Bottom of boring.
										WELL DEVELOPMENT Boring flushed with drill water until return drill water appeared visually clear. Boring bailed dry and a 2" diameter well installed. WELL MATERIAL 2" diameter 20 slot screen, 2" sch. 40 casing.		

AMERICAN ELECTRIC POWER SERVICE CORPORATION
AEP CIVIL ENGINEERING LABORATORY
 LOG OF BORING



JOB NUMBER _____
 COMPANY **APPALACHIAN POWER COMPANY**
 PROJECT **MOUNTAINEER LBR LANDFILL**
 COORDINATES **N 711,982.1 E 1,729,623.0**
 GROUND ELEVATION **800.5** SYSTEM _____

BORING NO. **MW-07** DATE **7/23/15** SHEET **1** OF **4**
 BORING START **5/21/92** BORING FINISH **6/19/92**
 PIEZOMETER TYPE _____ WELL TYPE **GM**
 HGT. RISER ABOVE GROUND **2.3** DIA **1.0**
 DEPTH TO TOP OF WELL SCREEN **53.2** BOTTOM **55.2**
 WELL DEVELOPMENT **SEE NOTES** BACKFILL **VOLCLAY GROUT**
 FIELD PARTY **TJH/RLY** RIG **CME-75**

Water Level, ft	▽ 23.1	▼ 28.0	▽
TIME	0710	0720	
DATE	5-27-92	5-28-92	

SAMPLE NUMBER	SAMPLE	SAMPLE DEPTH IN FEET		STANDARD PENETRATION RESISTANCE BLOWS / 6"	TOTAL LENGTH RECOVERY	RQD %	DEPTH IN FEET	GRAPHIC LOG	USCS	SOIL / ROCK IDENTIFICATION	WELL	DRILLER'S NOTES
		FROM	TO									
1	SS	2.3	3.8	11-12-18	.5	0	5			BROWN CLAY		
2	SS	7.3	8.8	12-17-21	1.3		10					
3	SS	12.3	13.8	14-39-47	1.0		15			BROWN SHALEY CLAY		
1	NQ	13.8	15.3		.5	0				BROWN CLAY		
2	NQ	15.3	21.7		4.4	14				RED SHALE		

TYPE OF CASING USED

<input checked="" type="checkbox"/>	NQ-2 ROCK CORE
<input checked="" type="checkbox"/>	6" x 3.25 HSA
	9" x 6.25 HSA
	HW CASING ADVANCER 4"
	NW CASING 3"
	SW CASING 6"
	AIR HAMMER 8"

Continued Next Page

PIEZOMETER TYPE: PT = OPEN TUBE POROUS TIP, SS = OPEN TUBE SLOTTED SCREEN, G = GEONOR, P = PNEUMATIC
 WELL TYPE: OW = OPEN TUBE SLOTTED SCREEN, GM = GEOMON

RECORDER _____

AMERICAN ELECTRIC POWER SERVICE CORPORATION
AEP CIVIL ENGINEERING LABORATORY
 LOG OF BORING



JOB NUMBER _____

COMPANY **APPALACHIAN POWER COMPANY**

BORING NO. **MW-07** DATE **7/23/15** SHEET **2** OF **4**

PROJECT **MOUNTAINEER LBR LANDFILL**

BORING START **5/21/92** BORING FINISH **6/19/92**

SAMPLE NUMBER	SAMPLE	SAMPLE DEPTH IN FEET		STANDARD PENETRATION RESISTANCE BLOWS / 6"	TOTAL LENGTH RECOVERY	RQD	DEPTH IN FEET	GRAPHIC LOG	USCS	SOIL / ROCK IDENTIFICATION	WELL	DRILLER'S NOTES
		FROM	TO			%						
3	NQ	21.7	24.8		2.5	55				BROWN SANDSTONE weathered oxidized lens		Lost water return.
4	NQ	24.8	34.8		9.5	30	25					24.0 Top of bentonite seal.
										GRAY SHALE hard some oxidized		
							30					29.8 Top of gravel pack.
5	NQ	34.8	44.8		10.0	95	35					
										GRAY SANDSTONE hard		
							40					
6	NQ	44.8	54.8		10.0	84	45					

AEP_Mt.LBR.LF.FKA.SI.GPJ_AEP.GDT_7/23/15

Continued Next Page

AMERICAN ELECTRIC POWER SERVICE CORPORATION
AEP CIVIL ENGINEERING LABORATORY
 LOG OF BORING



JOB NUMBER _____

COMPANY **APPALACHIAN POWER COMPANY**

BORING NO. **MW-07** DATE **7/23/15** SHEET **3** OF **4**

PROJECT **MOUNTAINEER LBR LANDFILL**

BORING START **5/21/92** BORING FINISH **6/19/92**

SAMPLE NUMBER	SAMPLE	SAMPLE DEPTH IN FEET		STANDARD PENETRATION RESISTANCE BLOWS / 6"	TOTAL LENGTH RECOVERY	RQD	DEPTH IN FEET	GRAPHIC LOG	USCS	SOIL / ROCK IDENTIFICATION	WELL	DRILLER'S NOTES
		FROM	TO			%						
							50					
7	NQ	54.8	64.8		10.0	67	55			GRAY SHALE soft with some red lens		53.2 Top of screen. 55.2 Bottom of screen.
							60			GRAY SHALE hard some what sandy to 64.8		57.0 Bottom of gravel pack.
8	NQ	64.8	74.8		10.0	98	65			GRAY SHALE hard with red lens to 70.4		
							70					

AEP MT LBR LF FKA SI/GPJ AEP.GDT 7/23/15

Continued Next Page

AMERICAN ELECTRIC POWER SERVICE CORPORATION
AEP CIVIL ENGINEERING LABORATORY
 LOG OF BORING



JOB NUMBER _____

COMPANY **APPALACHIAN POWER COMPANY**

BORING NO. **MW-07** DATE **7/23/15** SHEET **4** OF **4**

PROJECT **MOUNTAINEER LBR LANDFILL**

BORING START **5/21/92** BORING FINISH **6/19/92**

SAMPLE NUMBER	SAMPLE	SAMPLE DEPTH IN FEET		STANDARD PENETRATION RESISTANCE BLOWS / 6"	TOTAL LENGTH RECOVERY	RQD	DEPTH IN FEET	GRAPHIC LOG	USCS	SOIL / ROCK IDENTIFICATION	WELL	DRILLER'S NOTES
		FROM	TO			%						
9	NQ	74.8	84.8		10.0	92	75		GRAY SANDSTONE hard		
							80				
10	NQ	84.8	91.0		6.2	74	85			GRAY SHALE hard with red lens		
										GRAY SHALE hard		
										GRAY SHALE soft		
										RED SHALE medium hard		
		91.0					90					
										WELL DEVELOPMENT Boring flushed with drill water until return water visually clear. Geomon type monitoring well was installed and purged until visually clear sample was obtained. WELL MATERIAL 1.25" diameter 20 slot screen, 1" sch. 80 pvc casing.		91.0 Bottom of boring.

AMERICAN ELECTRIC POWER SERVICE CORPORATION
AEP CIVIL ENGINEERING LABORATORY
 LOG OF BORING



JOB NUMBER _____
 COMPANY **APPALACHIAN POWER COMPANY**
 PROJECT **MOUNTAINEER LBR LANDFILL**
 COORDINATES **N 710,780.9 E 1,730,856.4**
 GROUND ELEVATION **675.5** SYSTEM _____

BORING NO. **MW-08** DATE **7/23/15** SHEET **1** OF **5**
 BORING START **7/22/92** BORING FINISH **7/29/92**
 PIEZOMETER TYPE _____ WELL TYPE **OW**
 HGT. RISER ABOVE GROUND **1.73** DIA **2.0**
 DEPTH TO TOP OF WELL SCREEN **44.0** BOTTOM **52.9**
 WELL DEVELOPMENT **SEE NOTES** BACKFILL **VOLCLAY GROUT**
 FIELD PARTY **TJH-GCF** RIG **CME-75**

Water Level, ft	▽ 6.1	▼	▼
TIME	0730		
DATE	7-23-92		

SAMPLE NUMBER	SAMPLE	SAMPLE DEPTH IN FEET		STANDARD PENETRATION RESISTANCE BLOWS / 6"	TOTAL LENGTH RECOVERY	RQD %	DEPTH IN FEET	GRAPHIC LOG	USCS	SOIL / ROCK IDENTIFICATION	WELL	DRILLER'S NOTES
		FROM	TO									
1	SS	3.5	5.0	5-8-9	1.2		5			BROWN/TAN CLAYEY SILT with rock fragments.		Hole reamed to 6" and installed well
2	SS	8.5	10.0	6-11-14	1.3	10			BROWN/TAN SANDY CLAY with clay shale soft to medium throughout			
3	SS	13.5	15.0	6-10-12	1.5	15						
4	SS	18.5	18.7	50/2	.2				RED CLAY SHALE soft to hard			

TYPE OF CASING USED

<input checked="" type="checkbox"/>	NQ-2 ROCK CORE
<input checked="" type="checkbox"/>	6" x 3.25 HSA
	9" x 6.25 HSA
	HW CASING ADVANCER 4"
	NW CASING 3"
	SW CASING 6"
	AIR HAMMER 8"

Continued Next Page

PIEZOMETER TYPE: PT = OPEN TUBE POROUS TIP, SS = OPEN TUBE SLOTTED SCREEN, G = GEONOR, P = PNEUMATIC
 WELL TYPE: OW = OPEN TUBE SLOTTED SCREEN, GM = GEOMON

RECORDER _____

AMERICAN ELECTRIC POWER SERVICE CORPORATION
AEP CIVIL ENGINEERING LABORATORY
 LOG OF BORING



JOB NUMBER _____

COMPANY **APPALACHIAN POWER COMPANY**

BORING NO. **MW-08** DATE **7/23/15** SHEET **2** OF **5**

PROJECT **MOUNTAINEER LBR LANDFILL**

BORING START **7/22/92** BORING FINISH **7/29/92**

SAMPLE NUMBER	SAMPLE	SAMPLE DEPTH IN FEET		STANDARD PENETRATION RESISTANCE BLOWS / 6"	TOTAL LENGTH RECOVERY	RQD	DEPTH IN FEET	GRAPHIC LOG	USCS	SOIL / ROCK IDENTIFICATION	WELL	DRILLER'S NOTES
		FROM	TO			%						
5	NQ-2	20.5	24.7		2.8	25				RED CLAY SHALE soft to hard		
6	NQ-2	24.7	31.6		5.3	68	25			GRAY CLAY SHALE medium to hard fine grain sandy shale 31.6 to 32.7		
7	NQ-2	31.6	34.7		2.8	45						
8	NQ-2	34.7	44.7		10.0		35					
										BLUE/GRAY SHALE AND CLAYEY SANDSTONE		36.6 Top of bentonite seal.
							40					42.6 Top of gravel pack.
9	NQ-2	44.7	54.7		10.0	98	45					44.0 Top of screen.

AEP MT LBR LF FKA SI/GPJ AEP.GDT 7/23/15

Continued Next Page

AMERICAN ELECTRIC POWER SERVICE CORPORATION
AEP CIVIL ENGINEERING LABORATORY
 LOG OF BORING



JOB NUMBER _____

COMPANY **APPALACHIAN POWER COMPANY**

BORING NO. **MW-08** DATE **7/23/15** SHEET **3** OF **5**

PROJECT **MOUNTAINEER LBR LANDFILL**

BORING START **7/22/92** BORING FINISH **7/29/92**

SAMPLE NUMBER	SAMPLE	SAMPLE DEPTH IN FEET		STANDARD PENETRATION RESISTANCE BLOWS / 6"	TOTAL LENGTH RECOVERY	RQD	DEPTH IN FEET	GRAPHIC LOG	USCS	SOIL / ROCK IDENTIFICATION	WELL	DRILLER'S NOTES
		FROM	TO			%						
							50			GRAY SANDSTONE hard		
										GRAY CLAY SHALE AND CLAYEY SANDSTONE		52.9 Bottom of screen.
10	NQ-2	54.7	61.8		6.9		55			RED AND GRAY CLAY SHALE medium to hard		55.0 Bottom of gravel pack.
							60			BLACK AND GRAY CLAY SHALE MEDIUM TO HARD WITH RUST STAIN. 61.5 TO 61.7 COAL		
										GRAY AND GREEN LAYERED CLAY SHALE soft to medium with rust stain, 61.5 to 61.7		
11	NQ-2	61.8	64.7		2.7					RED CLAY SHALE		
12	NQ-2	64.7	69.7		4.1	41	65					
13	NQ-2	69.7	74.7		5.0	100	70			BLUE AND GRAY CLAY SHALE hard with calcite throughout soft areas 72.7 TO 72.8 and 73.4 TO 73.5		

AEP MT LBR LF FKA SJG/PJ AEP.GDT 7/23/15

Continued Next Page

AMERICAN ELECTRIC POWER SERVICE CORPORATION
AEP CIVIL ENGINEERING LABORATORY
 LOG OF BORING



JOB NUMBER _____

COMPANY **APPALACHIAN POWER COMPANY**

BORING NO. **MW-08** DATE **7/23/15** SHEET **4** OF **5**

PROJECT **MOUNTAINEER LBR LANDFILL**

BORING START **7/22/92** BORING FINISH **7/29/92**

SAMPLE NUMBER	SAMPLE	SAMPLE DEPTH IN FEET		STANDARD PENETRATION RESISTANCE BLOWS / 6"	TOTAL LENGTH RECOVERY	RQD	DEPTH IN FEET	GRAPHIC LOG	U S C S	SOIL / ROCK IDENTIFICATION	WELL	DRILLER'S NOTES
		FROM	TO			%						
14	NQ-2	74.7	84.7		9.7	92	75			GRAY/BLUE CLAY SHALE hard,soft lens 85.5 TO 85.7		
15	NQ-2	84.7	94.7		9.7	97	85					
16	NQ-2	94.7	102.2		6.2		95			RED CLAY SHALE hard gray/green seams , rust stains 92.1 TO 92.6		

AEP MT LBR LF FKA SI/GPJ AEP.GDT 7/23/15

Continued Next Page

AMERICAN ELECTRIC POWER SERVICE CORPORATION
AEP CIVIL ENGINEERING LABORATORY
 LOG OF BORING



JOB NUMBER _____

COMPANY **APPALACHIAN POWER COMPANY**

BORING NO. **MW-08** DATE **7/23/15** SHEET **5** OF **5**

PROJECT **MOUNTAINEER LBR LANDFILL**

BORING START **7/22/92** BORING FINISH **7/29/92**

SAMPLE NUMBER	SAMPLE	SAMPLE DEPTH IN FEET		STANDARD PENETRATION RESISTANCE BLOWS / 6"	TOTAL LENGTH RECOVERY	RQD	DEPTH IN FEET	GRAPHIC LOG	USCS	SOIL / ROCK IDENTIFICATION	WELL	DRILLER'S NOTES
		FROM	TO			%						
17	NQ-2	102.2	104.7		2.3		100					
										CLAY SHALE hard		
										GRAY LIMESTONE ? hard		
										WELL DEVELOPMENT Boring was flushed with drill water until return water was visually clear. 2" diameter well was installed and pumped until a visually clear sample was obtained. WELL MATERIAL 2" diameter 20 slot screen, 2" diameter sch. 40 casing.		104.7 Bottom of boring.

AMERICAN ELECTRIC POWER SERVICE CORPORATION
AEP CIVIL ENGINEERING LABORATORY
 LOG OF BORING



JOB NUMBER _____
 COMPANY **APPALACHIAN POWER COMPANY**
 PROJECT **MOUNTAINEER LBR LANDFILL**
 COORDINATES **N 712,268.5 E 1,732,217.4**
 GROUND ELEVATION **643.0** SYSTEM _____

BORING NO. **MW-09** DATE **7/23/15** SHEET **1** OF **3**
 BORING START **8/12/92** BORING FINISH **8/13/92**
 PIEZOMETER TYPE _____ WELL TYPE **OW**
 HGT. RISER ABOVE GROUND **1.9** DIA **2.0**
 DEPTH TO TOP OF WELL SCREEN **43.8** BOTTOM **52.9**
 WELL DEVELOPMENT **SEE NOTES** BACKFILL **VOLCLAY GROUT**
 FIELD PARTY **TJH-GCF** RIG **CME-75**

Water Level, ft	▽ 14.0	▼ 0.0	▽
TIME	0730	.730	
DATE	7-29-92	7-30-92	

SAMPLE NUMBER	SAMPLE	SAMPLE DEPTH IN FEET		STANDARD PENETRATION RESISTANCE BLOWS / 6"	TOTAL LENGTH RECOVERY	RQD %	DEPTH IN FEET	GRAPHIC LOG	USCS	SOIL / ROCK IDENTIFICATION	WELL	DRILLER'S NOTES
		FROM	TO									
1	SS	3.8	5.3	5-8-9	1.1		5			BROWN CLAY SILT moist BLUE/GRAY SANDY CLAY SILT wet		Hole was reamed to 6" and well installed.
2	SS	8.8	10.3	1-1-1	1.3		10					
3	SS	13.8	15.3	3-3-4	0		15					
4	SS	18.8	20.3	3-4-3	1.5					BLUE SANDY CLAY SHALE trace of sand, saturated		

TYPE OF CASING USED	
<input checked="" type="checkbox"/>	NQ-2 ROCK CORE
<input checked="" type="checkbox"/>	6" x 3.25 HSA
	9" x 6.25 HSA
	HW CASING ADVANCER 4"
	NW CASING 3"
<input checked="" type="checkbox"/>	SW CASING 6"
	AIR HAMMER 8"

Continued Next Page

PIEZOMETER TYPE: PT = OPEN TUBE POROUS TIP, SS = OPEN TUBE SLOTTED SCREEN, G = GEONOR, P = PNEUMATIC

WELL TYPE: OW = OPEN TUBE SLOTTED SCREEN, GM = GEOMON

RECORDER _____

AEP_Mt.LBR.LF.FKA.SI.GPJ.AEP.GDT.7/23/15

AMERICAN ELECTRIC POWER SERVICE CORPORATION
AEP CIVIL ENGINEERING LABORATORY
 LOG OF BORING



JOB NUMBER _____

COMPANY **APPALACHIAN POWER COMPANY**

BORING NO. **MW-09** DATE **7/23/15** SHEET **2** OF **3**

PROJECT **MOUNTAINEER LBR LANDFILL**

BORING START **8/12/92** BORING FINISH **8/13/92**

SAMPLE NUMBER	SAMPLE	SAMPLE DEPTH IN FEET		STANDARD PENETRATION RESISTANCE BLOWS / 6"	TOTAL LENGTH RECOVERY	RQD	DEPTH IN FEET	GRAPHIC LOG	USCS	SOIL / ROCK IDENTIFICATION	WELL	DRILLER'S NOTES	
		FROM	TO			%							
5	SS	23.8	24.0	50/2	.2	0	25			GREEN SANDY CLAY SHALE			
6	NQ-2	24.0	25.3		.9								GREEN/GRAY SANDY SHALE soft to medium with vertical cracks 24.7 to 24.9
7	NQ-2	25.3	35.3		9.3	31	30			GRAY SANDSTONE medium to hard			
													GRAY/RED CLAY SHALE soft
8	NQ-2	35.3	40.3		2.6	0	35					36.8 Top of bentonite seal.	
9	NQ-2	40.3	43.4		2.1		40					42.9 Top of gravel pack.	
10	NQ-2	43.4	45.3		1.7								43.8 Top of screen.
11	NQ-2	45.3	55.3		9.4		45						
										GRAY CLAY SHALE medium to hard			

AEP MT LBR LF FKA SI/GPJ AEP.GDT 7/23/15

Continued Next Page

AMERICAN ELECTRIC POWER SERVICE CORPORATION
AEP CIVIL ENGINEERING LABORATORY
 LOG OF BORING



JOB NUMBER _____

COMPANY **APPALACHIAN POWER COMPANY**

BORING NO. **MW-09** DATE **7/23/15** SHEET **3** OF **3**

PROJECT **MOUNTAINEER LBR LANDFILL**

BORING START **8/12/92** BORING FINISH **8/13/92**

SAMPLE NUMBER	SAMPLE	SAMPLE DEPTH IN FEET		STANDARD PENETRATION RESISTANCE BLOWS / 6"	TOTAL LENGTH RECOVERY	RQD	DEPTH IN FEET	GRAPHIC LOG	USCS	SOIL / ROCK IDENTIFICATION	WELL	DRILLER'S NOTES
		FROM	TO			%						
							50			SHALEY SANDSTONE medium to hard		52.9 Bottom of screen.
							55			GRAY CLAY SHALE medium to hard		
										WELL DEVELOPMENT Hole was flushed with drill water until drill water was visually clear. A 2" monitoring well was installed and pumped until visually clean and a sample was obtained. WELL MATERIAL 2" diameter 20 slot screen pvc 2" diameter sch. 40 pvc casing.		55.3 Bottom of gravel pack and bottom of boring.

AMERICAN ELECTRIC POWER SERVICE CORPORATION
AEP CIVIL ENGINEERING LABORATORY
 LOG OF BORING



JOB NUMBER _____
 COMPANY **APPALACHIAN POWER COMPANY**
 PROJECT **MOUNTAINEER LBR LANDFILL**
 COORDINATES **N 710,968.6 E 1,730,231.8**
 GROUND ELEVATION **810.8** SYSTEM _____

BORING NO. **MW-10** DATE **7/23/15** SHEET **1** OF **7**
 BORING START **6/23/92** BORING FINISH **7/8/92**
 PIEZOMETER TYPE _____ WELL TYPE **GM-OW**
 HGT. RISER ABOVE GROUND **2.27-2.8** DIA **211**
 DEPTH TO TOP OF WELL SCREEN **87.1-149.8** ~~109.8~~ **89.1-148.9**
 WELL DEVELOPMENT **SEE NOTES** BACKFILL **VOLCLAY GROUT**
 FIELD PARTY **TJH\RLY** RIG **CME-75**

Water Level, ft	▽ 14.7	▼ 31.6	▼ 58.4
TIME	0705	0710	0850
DATE	6-24-92	6-25-92	7-1-92

SAMPLE NUMBER	SAMPLE	SAMPLE DEPTH IN FEET		STANDARD PENETRATION RESISTANCE BLOWS / 6"	TOTAL LENGTH RECOVERY	RQD %	DEPTH IN FEET	GRAPHIC LOG	USCS	SOIL / ROCK IDENTIFICATION	WELL	DRILLER'S NOTES
		FROM	TO									
1	SS	2.2	3.7	8-12-15	1.2		5			RED SANDY CLAY		Reamed hole to 6" and installed wells MW-10 and MW-11.
2	SS	7.2	7.4	50/.2	.2					BROWN SAND		
3	NQ	9.0	15.0		6.0	19	10			BROWN SANDSTONE		
										BROWN SANDY SHALE		
4	NQ	15.0	25.0		10.0	23	15			BROWN SHALE hard BROWN SANDSTONE		
										BROWN SHALE soft		

TYPE OF CASING USED

<input checked="" type="checkbox"/>	NQ-2 ROCK CORE
<input checked="" type="checkbox"/>	6" x 3.25 HSA
	9" x 6.25 HSA
	HW CASING ADVANCER 4"
	NW CASING 3"
<input checked="" type="checkbox"/>	SW CASING 6"
	AIR HAMMER 8"

Continued Next Page

PIEZOMETER TYPE: PT = OPEN TUBE POROUS TIP, SS = OPEN TUBE SLOTTED SCREEN, G = GEONOR, P = PNEUMATIC
 WELL TYPE: OW = OPEN TUBE SLOTTED SCREEN, GM = GEOMON

RECORDER _____

AMERICAN ELECTRIC POWER SERVICE CORPORATION
AEP CIVIL ENGINEERING LABORATORY
 LOG OF BORING



JOB NUMBER _____

COMPANY **APPALACHIAN POWER COMPANY**

BORING NO. **MW-10** DATE **7/23/15** SHEET **2** OF **7**

PROJECT **MOUNTAINEER LBR LANDFILL**

BORING START **6/23/92** BORING FINISH **7/8/92**

SAMPLE NUMBER	SAMPLE	SAMPLE DEPTH IN FEET		STANDARD PENETRATION RESISTANCE BLOWS / 6"	TOTAL LENGTH RECOVERY	RQD	DEPTH IN FEET	GRAPHIC LOG	USCS	SOIL / ROCK IDENTIFICATION	WELL	DRILLER'S NOTES
		FROM	TO			%						
5	NQ	25.0	33.6		4.0	20	25			RED SHALE soft		
6	NQ	33.6	35.0		1.3	92	30			GRAY SHALE	▼	
7	NQ	35.0	45.0		10.0	64	35					
							40			GRAY SANDSTONE with oxidized breaks 41.0-42.7		
							45			GRAY SHALE hard and medium from 49.2 to 49.8		
8	NQ	45.0	55.0		9.4	50	45					

AEP_Mt.LBR.LF.FKA.SI.GPJ_AEP.GDT_7/23/15

Continued Next Page

AMERICAN ELECTRIC POWER SERVICE CORPORATION
AEP CIVIL ENGINEERING LABORATORY
 LOG OF BORING



JOB NUMBER _____

COMPANY **APPALACHIAN POWER COMPANY**

BORING NO. **MW-10** DATE **7/23/15** SHEET **3** OF **7**

PROJECT **MOUNTAINEER LBR LANDFILL**

BORING START **6/23/92** BORING FINISH **7/8/92**

SAMPLE NUMBER	SAMPLE	SAMPLE DEPTH IN FEET		STANDARD PENETRATION RESISTANCE BLOWS / 6"	TOTAL LENGTH RECOVERY	RQD	DEPTH IN FEET	GRAPHIC LOG	USCS	SOIL / ROCK IDENTIFICATION	WELL	DRILLER'S NOTES
		FROM	TO			%						
							50			BROWN SANDSTONE		
										BROWN SHALE		
										GRAY SHALE medium hard oxidized breaks some high angle fracture and calcite		
9	NQ	55.0	65.0		10.0	50	55					
							60					
										BROWN SANDSTONE with oxidation throughout to 65.0 and coarse to 68.2		63.5 Top of bentonite seal.
10	NQ	65.0	73.9		8.9	50	65					
										GRAY SANDSTONE		
							70			GRAY SHALE		
												71.3 Top of gravel

AEP MT LBR LF FKA SIGPJ AEP.GDT 7/23/15

Continued Next Page

AMERICAN ELECTRIC POWER SERVICE CORPORATION
AEP CIVIL ENGINEERING LABORATORY
 LOG OF BORING



JOB NUMBER _____

COMPANY **APPALACHIAN POWER COMPANY**

BORING NO. **MW-10** DATE **7/23/15** SHEET **4** OF **7**

PROJECT **MOUNTAINEER LBR LANDFILL**

BORING START **6/23/92** BORING FINISH **7/8/92**

SAMPLE NUMBER	SAMPLE	SAMPLE DEPTH IN FEET		STANDARD PENETRATION RESISTANCE BLOWS / 6"	TOTAL LENGTH RECOVERY	RQD	DEPTH IN FEET	GRAPHIC LOG	USCS	SOIL / ROCK IDENTIFICATION	WELL	DRILLER'S NOTES
		FROM	TO			%						
11	NQ	73.9	75.0		1.1	100	75			BROWN SANDSTONE with oxidized fracture at 77.7 and changing to gray at 78.0 to 85		pack.
12	NQ	75.0	85.0		10.0	68	80					
13	NQ	85.0	95.0		10.0	79	85			GRAY SANDY SHALE hard		87.1 Top of screen.
							90			BROWN SANDSTONE with oxidized fracture GRAY SANDY SHALE		89.1 Bottom of screen. GEOMOND TIP
14	NQ	95.0	105.0		10.0	68	95			RED SHALE hard GRAY SHALE		92.1 Bottom of gravel pack.

AEP_Mt_LBR_LF_FKA_SiGPJ_AEP.GDT_7/23/15

Continued Next Page

AMERICAN ELECTRIC POWER SERVICE CORPORATION
AEP CIVIL ENGINEERING LABORATORY
 LOG OF BORING



JOB NUMBER _____

COMPANY **APPALACHIAN POWER COMPANY**

BORING NO. **MW-10** DATE **7/23/15** SHEET **5** OF **7**

PROJECT **MOUNTAINEER LBR LANDFILL**

BORING START **6/23/92** BORING FINISH **7/8/92**

SAMPLE NUMBER	SAMPLE	SAMPLE DEPTH IN FEET		STANDARD PENETRATION RESISTANCE BLOWS / 6"	TOTAL LENGTH RECOVERY	RQD	DEPTH IN FEET	GRAPHIC LOG	USCS	SOIL / ROCK IDENTIFICATION	WELL	DRILLER'S NOTES
		FROM	TO			%						
							100			GRAY SANDY SHALE		
							105			RED SHALE soft from 105.0 to 107.0		
15	NQ	105.0	115.0		9.6	54				GRAY SHALE		
							115			RED SHALE		
16	NQ	115.0	125.0		10.0	76				GRAY SHALE		

AEP MT LBR LF FKA SI/GPJ AEP.GDT 7/23/15

Continued Next Page

AMERICAN ELECTRIC POWER SERVICE CORPORATION
AEP CIVIL ENGINEERING LABORATORY
 LOG OF BORING



JOB NUMBER _____

COMPANY **APPALACHIAN POWER COMPANY**

BORING NO. **MW-10** DATE **7/23/15** SHEET **6** OF **7**

PROJECT **MOUNTAINEER LBR LANDFILL**

BORING START **6/23/92** BORING FINISH **7/8/92**

SAMPLE NUMBER	SAMPLE	SAMPLE DEPTH IN FEET		STANDARD PENETRATION RESISTANCE BLOWS / 6"	TOTAL LENGTH RECOVERY	RQD	DEPTH IN FEET	GRAPHIC LOG	USCS	SOIL / ROCK IDENTIFICATION	WELL	DRILLER'S NOTES
		FROM	TO			%						
17	NQ	125.0	130.0		4.5	50	125			RED SHALE soft from 130.0 to 135.0 and 135.0 to 137.1 high angle fracture		
18	NQ	130.0	135.0		4.0	36	130					
19	NQ	135.0	142.8		7.4	68	135			GRAY SHALE		
										GRAY SANDSTONE		137.0 Top of gravel pack. 139.9 Top of screen.
20	NQ	142.8	145.0		2.2	100	140					
21	NQ	145.0	152.2		7.1	74	145			GRAY SHALE		148.9 Bottom of screen.

AEP MT LBR LF FKA SI/GPJ AEP.GDT 7/23/15

Continued Next Page

AMERICAN ELECTRIC POWER SERVICE CORPORATION
AEP CIVIL ENGINEERING LABORATORY
 LOG OF BORING



JOB NUMBER _____

COMPANY **APPALACHIAN POWER COMPANY**

BORING NO. **MW-10** DATE **7/23/15** SHEET **7** OF **7**

PROJECT **MOUNTAINEER LBR LANDFILL**

BORING START **6/23/92** BORING FINISH **7/8/92**

SAMPLE NUMBER	SAMPLE	SAMPLE DEPTH IN FEET		STANDARD PENETRATION RESISTANCE BLOWS / 6"	TOTAL LENGTH RECOVERY	RQD	DEPTH IN FEET	GRAPHIC LOG	USCS	SOIL / ROCK IDENTIFICATION	WELL	DRILLER'S NOTES
		FROM	TO			%						
										RED SHALE		150.0 Bottom of gravel pack.
										MONITORING WELL MW-11 IS NESTED IN THE SAME BORING HOLE WITH MW-10. MONITORING WELL MW-11 COORDINATES N.710,968.29 E.1,730,231.77 ELEVATION 810.83 CASING ELEVATION 813.63 2" DIAMETER 20 SLOT SCREEN. 2" DIAMETER SCH. 40 PVC. WELL DEVELOPMENT Hole was flushed with drill water until return water appeared visually clear. Hole was bailed dry and a geomon type monitoring well installed and purged.		152.2 Bottom of boring

AMERICAN ELECTRIC POWER SERVICE CORPORATION
AEP CIVIL ENGINEERING LABORATORY
 LOG OF BORING



JOB NUMBER _____
 COMPANY **APPALACHIAN POWER COMPANY**
 PROJECT **MOUNTAINEER LBR LANDFILL**
 COORDINATES **N 709,162.5 E 1,728,963.4**
 GROUND ELEVATION **856.9** SYSTEM _____

BORING NO. **MW-12** DATE **7/23/15** SHEET **1** OF **9**
 BORING START **4/22/92** BORING FINISH **5/6/92**
 PIEZOMETER TYPE _____ WELL TYPE **GM**
 HGT. RISER ABOVE GROUND **1.95** DIA **1.0-2.0**
 DEPTH TO TOP OF WELL SCREEN **190.6** BOTTOM **192.6**
 WELL DEVELOPMENT **SEE NOTES** BACKFILL **VOLCLAY GROUT**
 FIELD PARTY **HOWWELL/YATES** RIG **CME-75**

Water Level, ft	▽ 20.7	▽ 23.9	▽ 88.7
TIME	1330	0710	0720
DATE	4-27-92	4-28-92	4-29-92

SAMPLE NUMBER	SAMPLE	SAMPLE DEPTH IN FEET		STANDARD PENETRATION RESISTANCE BLOWS / 6"	TOTAL LENGTH RECOVERY	RQD %	DEPTH IN FEET	GRAPHIC LOG	USCS	SOIL / ROCK IDENTIFICATION	WELL	DRILLER'S NOTES
		FROM	TO									
1	SS	4.0	5.4	19-37-50/4	1.4		5			BROWN SILTY SANDSTONE		
2	SS	9.0	9.3	50/3	.3	82	10			YELLOW/BROWN SANDSTONE with red vertical clay seams 14.5 to 15.9		AUGER REFUSAL
1	NQ	9.3	15.3		6.0							
2	NQ	15.3	25.3		9.8	58	15					

TYPE OF CASING USED

Continued Next Page

<input checked="" type="checkbox"/>	NQ-2 ROCK CORE
<input checked="" type="checkbox"/>	6" x 3.25 HSA
	9" x 6.25 HSA
	HW CASING ADVANCER 4"
	NW CASING 3"
	SW CASING 6"
	AIR HAMMER 8"

PIEZOMETER TYPE: PT = OPEN TUBE POROUS TIP, SS = OPEN TUBE SLOTTED SCREEN, G = GEONOR, P = PNEUMATIC
 WELL TYPE: OW = OPEN TUBE SLOTTED SCREEN, GM = GEOMON

RECORDER _____

AEP_Mt.LBR.LF.FKA.SI.GPJ.AEP.GDT.7/23/15

AMERICAN ELECTRIC POWER SERVICE CORPORATION
AEP CIVIL ENGINEERING LABORATORY
 LOG OF BORING



JOB NUMBER _____

COMPANY **APPALACHIAN POWER COMPANY**

BORING NO. **MW-12** DATE **7/23/15** SHEET **2** OF **9**

PROJECT **MOUNTAINEER LBR LANDFILL**

BORING START **4/22/92** BORING FINISH **5/6/92**

SAMPLE NUMBER	SAMPLE	SAMPLE DEPTH IN FEET		STANDARD PENETRATION RESISTANCE BLOWS / 6"	TOTAL LENGTH RECOVERY	RQD	DEPTH IN FEET	GRAPHIC LOG	USCS	SOIL / ROCK IDENTIFICATION	WELL	DRILLER'S NOTES
		FROM	TO			%						
3	NQ	25.3	35.3		10.0	72	25					
							30			GRAY SANDSTONE		
4	NQ	35.3	36.3		.4	33	35					
5	NQ	36.3	40.3		1.7	18				RED SHALE		
6	NQ	40.3	44.0		45	45	40					
7	NQ	44.0	45.3		1.1	60				GRAY SHALE		
8	NQ	45.3	55.3		10.0	74	45					

AEP MT LBR LF FKA SI/GPJ AEP.GDT 7/23/15

Continued Next Page

AMERICAN ELECTRIC POWER SERVICE CORPORATION
AEP CIVIL ENGINEERING LABORATORY
 LOG OF BORING



JOB NUMBER _____

COMPANY **APPALACHIAN POWER COMPANY**

BORING NO. **MW-12** DATE **7/23/15** SHEET **3** OF **9**

PROJECT **MOUNTAINEER LBR LANDFILL**

BORING START **4/22/92** BORING FINISH **5/6/92**

SAMPLE NUMBER	SAMPLE	SAMPLE DEPTH IN FEET		STANDARD PENETRATION RESISTANCE BLOWS / 6"	TOTAL LENGTH RECOVERY	RQD	DEPTH IN FEET	GRAPHIC LOG	USCS	SOIL / ROCK IDENTIFICATION	WELL	DRILLER'S NOTES
		FROM	TO			%						
							50					0715 5-5-92 SWL 49.3 FT.
9	NQ	55.3	65.3		10.0	51	55			GRAY SANDY SHALE		
							60					
10	NQ	65.3	75.3		10.0	51	65			GRAY SHALE		
							70			RED SHALE		

AEP MT LBR LF FKA SI/GPJ AEP.GDT 7/23/15

Continued Next Page

AMERICAN ELECTRIC POWER SERVICE CORPORATION
AEP CIVIL ENGINEERING LABORATORY
 LOG OF BORING



JOB NUMBER _____

COMPANY **APPALACHIAN POWER COMPANY**

BORING NO. **MW-12** DATE **7/23/15** SHEET **4** OF **9**

PROJECT **MOUNTAINEER LBR LANDFILL**

BORING START **4/22/92** BORING FINISH **5/6/92**

SAMPLE NUMBER	SAMPLE	SAMPLE DEPTH IN FEET		STANDARD PENETRATION RESISTANCE BLOWS / 6"	TOTAL LENGTH RECOVERY	RQD	DEPTH IN FEET	GRAPHIC LOG	USCS	SOIL / ROCK IDENTIFICATION	WELL	DRILLER'S NOTES
		FROM	TO			%						
11	NQ	75.3	85.3		9.4	66	75					
										RED AND GRAY SHALE		
							80					
12	NQ	85.3	95.3		10.0	68	85			GRAY SHALE		
										RED SHALE		
							90			GRAY SHALE		
13	NQ	95.3	105.3		10.0	85	95					

AEP MT LBR LF FKA SI/GPJ AEP.GDT 7/23/15

Continued Next Page

AMERICAN ELECTRIC POWER SERVICE CORPORATION
AEP CIVIL ENGINEERING LABORATORY
 LOG OF BORING



JOB NUMBER _____

COMPANY **APPALACHIAN POWER COMPANY**

BORING NO. **MW-12** DATE **7/23/15** SHEET **5** OF **9**

PROJECT **MOUNTAINEER LBR LANDFILL**

BORING START **4/22/92** BORING FINISH **5/6/92**

SAMPLE NUMBER	SAMPLE	SAMPLE DEPTH IN FEET		STANDARD PENETRATION RESISTANCE BLOWS / 6"	TOTAL LENGTH RECOVERY	RQD	DEPTH IN FEET	GRAPHIC LOG	USCS	SOIL / ROCK IDENTIFICATION	WELL	DRILLER'S NOTES
		FROM	TO			%						
							100			GRAY SANDSTONE		Momentary loss of water. 1450 5-4-92 SWL 96 HRS.100.0
14	NQ	105.3	115.3		10.0	100	105					
							110			GRAY SHALE soft		
15	NQ	115.3	125.3		9.3	74	115			RED SHALE		
							120			GRAY SHALE hard		

AEP MT LBR LF FKA SI/GPJ AEP.GDT 7/23/15

Continued Next Page

AMERICAN ELECTRIC POWER SERVICE CORPORATION
AEP CIVIL ENGINEERING LABORATORY
 LOG OF BORING



JOB NUMBER _____

COMPANY **APPALACHIAN POWER COMPANY**

BORING NO. **MW-12** DATE **7/23/15** SHEET **6** OF **9**

PROJECT **MOUNTAINEER LBR LANDFILL**

BORING START **4/22/92** BORING FINISH **5/6/92**

SAMPLE NUMBER	SAMPLE	SAMPLE DEPTH IN FEET		STANDARD PENETRATION RESISTANCE BLOWS / 6"	TOTAL LENGTH RECOVERY	RQD	DEPTH IN FEET	GRAPHIC LOG	USCS	SOIL / ROCK IDENTIFICATION	WELL	DRILLER'S NOTES
		FROM	TO			%						
16	NQ	125.3	135.3		10.0	82	125			GRAY SANDSTONE hard		
							130			RED SHALE		
17	NQ	135.3	140.3		4.6	88	135			GRAY SHALE hard		
18	NQ	140.3	150.3		10.0	67	140					
							145			RED SHALE		

AEP MT LBR LF FKA SI/GPJ AEP.GDT 7/23/15

Continued Next Page

AMERICAN ELECTRIC POWER SERVICE CORPORATION
AEP CIVIL ENGINEERING LABORATORY
 LOG OF BORING



JOB NUMBER _____

COMPANY **APPALACHIAN POWER COMPANY**

BORING NO. **MW-12** DATE **7/23/15** SHEET **7** OF **9**

PROJECT **MOUNTAINEER LBR LANDFILL**

BORING START **4/22/92** BORING FINISH **5/6/92**

SAMPLE NUMBER	SAMPLE	SAMPLE DEPTH IN FEET		STANDARD PENETRATION RESISTANCE BLOWS / 6"	TOTAL LENGTH RECOVERY	RQD	DEPTH IN FEET	GRAPHIC LOG	USCS	SOIL / ROCK IDENTIFICATION	WELL	DRILLER'S NOTES
		FROM	TO			%						
19	NQ	150.3	155.3		4.9	68	150.3					HOLE CASED TO 153.7 FT.
20	NQ	155.3	165.3		10.0	82	155		GRAY SHALE hard			
							160					
21	NQ	165.3	170.3		4.6	89	165				166.0 Top of bentonite seal.	
22	NQ	170.3	175.3		4.1	28	170		RED SHALE with limestone nodules		172.0 Top of gravel pack.	
23	NQ	175.3	185.3		9.9	54	175					

AEP MT LBR LF FKA SI/GPJ AEP.GDT 7/23/15

Continued Next Page

AMERICAN ELECTRIC POWER SERVICE CORPORATION
AEP CIVIL ENGINEERING LABORATORY
 LOG OF BORING



JOB NUMBER _____

COMPANY **APPALACHIAN POWER COMPANY**

BORING NO. **MW-12** DATE **7/23/15** SHEET **8** OF **9**

PROJECT **MOUNTAINEER LBR LANDFILL**

BORING START **4/22/92** BORING FINISH **5/6/92**

SAMPLE NUMBER	SAMPLE	SAMPLE DEPTH IN FEET		STANDARD PENETRATION RESISTANCE BLOWS / 6"	TOTAL LENGTH RECOVERY	RQD		DEPTH IN FEET	GRAPHIC LOG	USCS	SOIL / ROCK IDENTIFICATION	WELL	DRILLER'S NOTES
		FROM	TO			%	%						
								180			GRAY SANDY SHALE		
								185			GRAY SHALEY SANDSTONE		
24	NQ	185.3	195.3		10.0	83		185			GRAY SANDSTONE		
								190					
								190.6					190.6 Top of screen.
								192.6					192.6 Bottom of screen.
								195			GRAY SHALE medium hard		194.0 Bottom of gravel pack.
25	NQ	195.3	200.3		4.6	45		195			GRAY SHALE hard		
											RED SHALE medium hard		
								200					200.3 Bottom of bore hole.

AEP MT LBR LF FKA SI/GPJ AEP.GDT 7/23/15

Continued Next Page

AMERICAN ELECTRIC POWER SERVICE CORPORATION
AEP CIVIL ENGINEERING LABORATORY
 LOG OF BORING



JOB NUMBER _____

COMPANY **APPALACHIAN POWER COMPANY**

BORING NO. **MW-12** DATE **7/23/15** SHEET **9** OF **9**

PROJECT **MOUNTAINEER LBR LANDFILL**

BORING START **4/22/92** BORING FINISH **5/6/92**

SAMPLE NUMBER	SAMPLE	SAMPLE DEPTH IN FEET		STANDARD PENETRATION RESISTANCE BLOWS / 6"	TOTAL LENGTH RECOVERY	RQD	DEPTH IN FEET	GRAPHIC LOG	USCS	SOIL / ROCK IDENTIFICATION	WELL	DRILLER'S NOTES
		FROM	TO			%						
										WELL DEVELOPMENT Hole was flushed with drill water until drill water was visually clear. Hole was bailed dry and a geomon type monitoring well was installed and purged until a visually clear sample was obtained. WELL MATERIAL 1.25" diameter 20 slot screen pvc. 1" sch. 80 pvc casing.		

AMERICAN ELECTRIC POWER SERVICE CORPORATION
AEP CIVIL ENGINEERING LABORATORY
 LOG OF BORING



JOB NUMBER _____
 COMPANY **APPALACHIAN POWER COMPANY**
 PROJECT **MOUNTAINEER LBR LANDFILL**
 COORDINATES **N 710,337.4 E 1,731,154.1**
 GROUND ELEVATION **802.0** SYSTEM _____

BORING NO. **MW-13** DATE **7/23/15** SHEET **1** OF **7**
 BORING START **5/7/92** BORING FINISH **5/13/92**
 PIEZOMETER TYPE _____ WELL TYPE **GM**
 HGT. RISER ABOVE GROUND **3.04** DIA **1.0**
 DEPTH TO TOP OF WELL SCREEN **151.4** BOTTOM **153.4**
 WELL DEVELOPMENT **SEE NOTES** BACKFILL **VOLCLAY GROUT**
 FIELD PARTY **HOWELLYATES** RIG **CME75**

Water Level, ft	▽ 18.4	▼ 23.9	▽ 44.0
TIME	1536	0750	0715
DATE	5-11-92	5-12-92	5-13-92

SAMPLE NUMBER	SAMPLE	SAMPLE DEPTH IN FEET		STANDARD PENETRATION RESISTANCE BLOWS / 6"	TOTAL LENGTH RECOVERY	RQD %	DEPTH IN FEET	GRAPHIC LOG	USCS	SOIL / ROCK IDENTIFICATION	WELL	DRILLER'S NOTES
		FROM	TO									
1	NQ-2	3.4	4.5		.6	0				BROWN SANDSTONE		
2	NQ-2	4.5	14.5		10.0	62	5					
3	NQ-2	14.5	24.5		8.0	27	15					
										GRAY SHALE, soft		

TYPE OF CASING USED

<input checked="" type="checkbox"/>	NQ-2 ROCK CORE
<input checked="" type="checkbox"/>	6" x 3.25 HSA
	9" x 6.25 HSA
	HW CASING ADVANCER 4"
	NW CASING 3"
	SW CASING 6"
	AIR HAMMER 8"

Continued Next Page

PIEZOMETER TYPE: PT = OPEN TUBE POROUS TIP, SS = OPEN TUBE SLOTTED SCREEN, G = GEONOR, P = PNEUMATIC
 WELL TYPE: OW = OPEN TUBE SLOTTED SCREEN, GM = GEOMON

RECORDER _____

AMERICAN ELECTRIC POWER SERVICE CORPORATION
AEP CIVIL ENGINEERING LABORATORY
 LOG OF BORING



JOB NUMBER _____

COMPANY **APPALACHIAN POWER COMPANY**

BORING NO. **MW-13** DATE **7/23/15** SHEET **2** OF **7**

PROJECT **MOUNTAINEER LBR LANDFILL**

BORING START **5/7/92** BORING FINISH **5/13/92**

SAMPLE NUMBER	SAMPLE	SAMPLE DEPTH IN FEET		STANDARD PENETRATION RESISTANCE BLOWS / 6"	TOTAL LENGTH RECOVERY	RQD	DEPTH IN FEET	GRAPHIC LOG	USCS	SOIL / ROCK IDENTIFICATION	WELL	DRILLER'S NOTES
		FROM	TO			%						
4	NQ-2	24.5	33.4		2.9	14	25			RED SHALE, soft		
5	NQ-2	33.4	34.5		1.1	50	35			GRAY SHALE hard		
6	NQ-2	34.5	44.5		10.0	59	35			GRAY SHALE medium hard		
7	NQ-2	44.5	54.5		10.0	54	45			RED SHALE soft		

AEP MT LBR LF FKA SI/GPJ AEP.GDT 7/23/15

Continued Next Page

AMERICAN ELECTRIC POWER SERVICE CORPORATION
AEP CIVIL ENGINEERING LABORATORY
 LOG OF BORING



JOB NUMBER _____

COMPANY **APPALACHIAN POWER COMPANY**

BORING NO. **MW-13** DATE **7/23/15** SHEET **3** OF **7**

PROJECT **MOUNTAINEER LBR LANDFILL**

BORING START **5/7/92** BORING FINISH **5/13/92**

SAMPLE NUMBER	SAMPLE	SAMPLE DEPTH IN FEET		STANDARD PENETRATION RESISTANCE BLOWS / 6"	TOTAL LENGTH RECOVERY	RQD	DEPTH IN FEET	GRAPHIC LOG	USCS	SOIL / ROCK IDENTIFICATION	WELL	DRILLER'S NOTES
		FROM	TO			%						
										GRAY SANDY SHALE hard		
							50			GRAY/BROWN SANDSTONE		
										GRAY SHALE		
										BROWN SHALEY SANDSTONE		
8	NQ-2	54.5	64.5		10.0	23	55			YELLOW SHALE hard oxidation throughout GRAY SHALE soft		
										BROWN SANDSTONE		
							60			GRAY SANDSTONE hard		
9	NQ-2	64.5	74.5		10.0	59	65			GRAY SHALE hard		
							70					

AEP MT LBR LF FKA SI/GPJ AEP.GDT 7/23/15

Continued Next Page

AMERICAN ELECTRIC POWER SERVICE CORPORATION
AEP CIVIL ENGINEERING LABORATORY
 LOG OF BORING



JOB NUMBER _____

COMPANY **APPALACHIAN POWER COMPANY**

BORING NO. **MW-13** DATE **7/23/15** SHEET **4** OF **7**

PROJECT **MOUNTAINEER LBR LANDFILL**

BORING START **5/7/92** BORING FINISH **5/13/92**

SAMPLE NUMBER	SAMPLE	SAMPLE DEPTH IN FEET		STANDARD PENETRATION RESISTANCE BLOWS / 6"	TOTAL LENGTH RECOVERY	RQD	DEPTH IN FEET	GRAPHIC LOG	USCS	SOIL / ROCK IDENTIFICATION	WELL	DRILLER'S NOTES
		FROM	TO			%						
10	NQ-2	74.5	84.5		10.0	83	75					
							80			GRAY SANDSTONE hard with oxidation and high angle fracture at 80.6		PARTIAL LOSS OF DRILL WATER
11	NQ-2	84.5	94.5		10.0	74	85		GRAY SHALE			
									RED SHALE			
							90		GRAY SHALE			
12	NQ-2	94.5	104.5		10.0	76	95			GRAY SANDY SHALE hard		

AEP MT LBR LF FKA SI/GPJ AEP.GDT 7/23/15

Continued Next Page

AMERICAN ELECTRIC POWER SERVICE CORPORATION
AEP CIVIL ENGINEERING LABORATORY
 LOG OF BORING



JOB NUMBER _____

COMPANY **APPALACHIAN POWER COMPANY**

BORING NO. **MW-13** DATE **7/23/15** SHEET **5** OF **7**

PROJECT **MOUNTAINEER LBR LANDFILL**

BORING START **5/7/92** BORING FINISH **5/13/92**

SAMPLE NUMBER	SAMPLE	SAMPLE DEPTH IN FEET		STANDARD PENETRATION RESISTANCE BLOWS / 6"	TOTAL LENGTH RECOVERY	RQD %	DEPTH IN FEET	GRAPHIC LOG	USCS	SOIL / ROCK IDENTIFICATION	WELL	DRILLER'S NOTES
		FROM	TO									
							100					
										RED SHALE medium hard		
13	NQ-2	104.5	114.5		10.0	79	105			GRAY SHALE hard		
							110					
										GRAY SANDSTONE		
14	NQ-2	114.5	124.5		10.0	87	115					
										GRAY SHALE hard		
										RED SHALE hard		
							120			GRAY SANDSTONE hard		

AEP MT LBR LF FKA SI/GPJ AEP.GDT 7/23/15

Continued Next Page

AMERICAN ELECTRIC POWER SERVICE CORPORATION
AEP CIVIL ENGINEERING LABORATORY
 LOG OF BORING



JOB NUMBER _____

COMPANY **APPALACHIAN POWER COMPANY**

BORING NO. **MW-13** DATE **7/23/15** SHEET **6** OF **7**

PROJECT **MOUNTAINEER LBR LANDFILL**

BORING START **5/7/92** BORING FINISH **5/13/92**

SAMPLE NUMBER	SAMPLE	SAMPLE DEPTH IN FEET		STANDARD PENETRATION RESISTANCE BLOWS / 6"	TOTAL LENGTH RECOVERY	RQD	DEPTH IN FEET	GRAPHIC LOG	USCS	SOIL / ROCK IDENTIFICATION	WELL	DRILLER'S NOTES
		FROM	TO			%						
15	NQ-2	124.5	132.5		7.8	73	125			GRAY SHALE hard		
										RED SHALE hard		128.0 Top of bentonite seal.
16	NQ-2	132.5	140.0		7.0	65	130			RED SHALE hard, high angle fractures		133.5 Top of gravel pack.
							135			GRAY SANDSTONE hard		
17	NQ-2	140.0	150.0		9.9	95	140			GRAY SANDSTONE hard		
							145					

AEP MT LBR LF FKA SI/GPJ AEP.GDT 7/23/15

Continued Next Page

AMERICAN ELECTRIC POWER SERVICE CORPORATION
AEP CIVIL ENGINEERING LABORATORY
 LOG OF BORING



JOB NUMBER _____

COMPANY **APPALACHIAN POWER COMPANY**

BORING NO. **MW-13** DATE **7/23/15** SHEET **7** OF **7**

PROJECT **MOUNTAINEER LBR LANDFILL**

BORING START **5/7/92** BORING FINISH **5/13/92**

SAMPLE NUMBER	SAMPLE	SAMPLE DEPTH IN FEET		STANDARD PENETRATION RESISTANCE BLOWS / 6"	TOTAL LENGTH RECOVERY	RQD	DEPTH IN FEET	GRAPHIC LOG	USCS	SOIL / ROCK IDENTIFICATION	WELL	DRILLER'S NOTES
		FROM	TO			%						
18	NQ-2	150.0	155.0		5.0	88				GRAY SANDSTONE hard		
							155			RED SHALE		151.4 Top of screen. 153.4 Bottom of screen.
							160			WELL DEVELOPMENT Hole was flushed with drill water until return water was visually clear. Hole was bailed and a geomon type monitoring well was installed and purged until a visually clear sample was obtained. WELL MATERIAL 1.25" diameter 20 slot screen pvc. 1" sch. 80 casing pvc.		155.0 Bottom of gravel pack and boring.

AMERICAN ELECTRIC POWER SERVICE CORPORATION
AEP CIVIL ENGINEERING LABORATORY
 LOG OF BORING



JOB NUMBER _____
 COMPANY **APPALACHIAN POWER COMPANY**
 PROJECT **MOUNTAINEER LBR LANDFILL**
 COORDINATES **N 710,272.6 E 1,729,225.4**
 GROUND ELEVATION **715.1** SYSTEM _____

BORING NO. **MW-14** DATE **7/23/15** SHEET **1** OF **3**
 BORING START **8/6/92** BORING FINISH **8/11/92**
 PIEZOMETER TYPE _____ WELL TYPE **OW**
 HGT. RISER ABOVE GROUND **1.77** DIA **2.0**
 DEPTH TO TOP OF WELL SCREEN **45.4** BOTTOM **54.9**
 WELL DEVELOPMENT **SEE NOTES** BACKFILL **VOLCLAY GROUT**
 FIELD PARTY **TJH-TLS** RIG **CME-75**

Water Level, ft	▽ 9.1	▼	▼
TIME	0715		
DATE	8-11-92		

SAMPLE NUMBER	SAMPLE	SAMPLE DEPTH IN FEET		STANDARD PENETRATION RESISTANCE BLOWS / 6"	TOTAL LENGTH RECOVERY	RQD %	DEPTH IN FEET	GRAPHIC LOG	USCS	SOIL / ROCK IDENTIFICATION	WELL	DRILLER'S NOTES
		FROM	TO									
1	SS	3.5	5.0	4-6-8	1.4		5			BROWN AND GRAY SILTY CLAY		Hole was reamed to 6" and well installed.
2	SS	8.5	9.3	42-50/3						RED CLAY SHALE weathered		
3	NQ-2	9.3	15.0		2.4	0	10			RED CLAY SHALE		
4	NQ-2	15.0	23.5		6.3	30	15					

TYPE OF CASING USED

Continued Next Page

<input checked="" type="checkbox"/>	NQ-2 ROCK CORE	
	6" x 3.25 HSA	
	9" x 6.25 HSA	
	HW CASING ADVANCER	4"
	NW CASING	3"
<input checked="" type="checkbox"/>	SW CASING	6"
	AIR HAMMER	8"

PIEZOMETER TYPE: PT = OPEN TUBE POROUS TIP, SS = OPEN TUBE SLOTTED SCREEN, G = GEONOR, P = PNEUMATIC
 WELL TYPE: OW = OPEN TUBE SLOTTED SCREEN, GM = GEOMON

RECORDER _____

AMERICAN ELECTRIC POWER SERVICE CORPORATION
AEP CIVIL ENGINEERING LABORATORY
 LOG OF BORING



JOB NUMBER _____

COMPANY **APPALACHIAN POWER COMPANY**

BORING NO. **MW-14** DATE **7/23/15** SHEET **2** OF **3**

PROJECT **MOUNTAINEER LBR LANDFILL**

BORING START **8/6/92** BORING FINISH **8/11/92**

SAMPLE NUMBER	SAMPLE	SAMPLE DEPTH IN FEET		STANDARD PENETRATION RESISTANCE BLOWS / 6"	TOTAL LENGTH RECOVERY	RQD	DEPTH IN FEET	GRAPHIC LOG	USCS	SOIL / ROCK IDENTIFICATION	WELL	DRILLER'S NOTES
		FROM	TO			%						
5	NQ-2	23.5	25.0		.5	27						
6	NQ-2	25.0	35.0		9.9	85	25			GRAY SILTY CLAY SHALE well cemented		
							30			GRAY CLAY SHALE v-soft		
7	NQ-2	35.0	43.2		6.0	12	35			RED AND GRAY CLAY SHALE soft		
							40			RED CLAY SHALE soft		38.2 Top of bentonite seal,
8	NQ-2	43.2	45.0		1.5	46				GRAY CLAY SHALE soft		
							45			GRAY CLAY SHALE well cemented		44.0 Top of gravel pack.
9	NQ-2	45.0	55.0		10.0	97				GRAY SANDY CLAY SHALE		45.4 Top of screen.

AEP MT LBR LF FKA SIGPJ AEP.GDT 7/23/15

Continued Next Page

AMERICAN ELECTRIC POWER SERVICE CORPORATION
AEP CIVIL ENGINEERING LABORATORY
 LOG OF BORING



JOB NUMBER _____

COMPANY **APPALACHIAN POWER COMPANY**

BORING NO. **MW-14** DATE **7/23/15** SHEET **3** OF **3**

PROJECT **MOUNTAINEER LBR LANDFILL**

BORING START **8/6/92** BORING FINISH **8/11/92**

SAMPLE NUMBER	SAMPLE	SAMPLE DEPTH IN FEET		STANDARD PENETRATION RESISTANCE BLOWS / 6"	TOTAL LENGTH RECOVERY	RQD	DEPTH IN FEET	GRAPHIC LOG	USCS	SOIL / ROCK IDENTIFICATION	WELL	DRILLER'S NOTES
		FROM	TO			%						
							50			GRAY SANDSTONE well cemented, fine grain		
10	NQ-2	55.0	59.0		3.7	45	55			GRAY SHALEY SANDSTONE GRAY SANDY SHALE		54.9 Bottom of screen.
										RED AND GRAY CLAY SHALE		56.4 Bottom of gravel pack and boring.
<p>WELL DEVELOPMENT Hole was flushed with drill water until return water was visually clear. Hole was bailed dry and a 2" well installed and pumped until a visually clear and a sample obtained.</p> <p>WELL MATERIAL 2" diameter 20 slot screen pvc. 2" diameter sch. 40 pvc casing.</p>												

AMERICAN ELECTRIC POWER SERVICE CORPORATION
AEP CIVIL ENGINEERING LABORATORY
 LOG OF BORING



JOB NUMBER _____
 COMPANY **APPALACHIAN POWER COMPANY**
 PROJECT **MOUNTAINEER LBR LANDFILL**
 COORDINATES **N 710,943.8 E 1,730,886.1**
 GROUND ELEVATION **679.3** SYSTEM _____

BORING NO. **MW-15** DATE **7/23/15** SHEET **1** OF **3**
 BORING START **7/13/92** BORING FINISH **7/22/92**
 PIEZOMETER TYPE _____ WELL TYPE **OW**
 HGT. RISER ABOVE GROUND **1.91** DIA **2.0**
 DEPTH TO TOP OF WELL SCREEN **44.9** BOTTOM **53.9**
 WELL DEVELOPMENT **SEE NOTES** BACKFILL **VOLCLAY GROUT**
 FIELD PARTY **TJH-RLY** RIG **CME-75**

Water Level, ft	▽ 48.5	▼	▼
TIME	0730		
DATE	7-14-92		

SAMPLE NUMBER	SAMPLE	SAMPLE DEPTH IN FEET		STANDARD PENETRATION RESISTANCE BLOWS / 6"	TOTAL LENGTH RECOVERY	RQD %	DEPTH IN FEET	GRAPHIC LOG	USCS	SOIL / ROCK IDENTIFICATION	WELL	DRILLER'S NOTES
		FROM	TO									
1	SS	2.7	4.2	24-22-21	1.4					RED CLAY BROWN SAND		Hole was reamed to 6" before installing well.
2	SS	7.7	9.2	6-7-8	1.2	5				BROWN SANDY SILT		
3	NQ-2	10.5	15.2		4.1	10				BROWN SANDY SHALE		
4	NQ-2	15.2	23.2		7.6	15				BROWN SANDSTONE GRAY CLAY SHALE soft RED CLAY SHALE soft		

TYPE OF CASING USED

<input checked="" type="checkbox"/>	NQ-2 ROCK CORE	
	6" x 3.25 HSA	
	9" x 6.25 HSA	
	HW CASING ADVANCER	4"
	NW CASING	3"
<input checked="" type="checkbox"/>	SW CASING	6"
	AIR HAMMER	8"

Continued Next Page

PIEZOMETER TYPE: PT = OPEN TUBE POROUS TIP, SS = OPEN TUBE SLOTTED SCREEN, G = GEONOR, P = PNEUMATIC
 WELL TYPE: OW = OPEN TUBE SLOTTED SCREEN, GM = GEOMON

RECORDER _____

AMERICAN ELECTRIC POWER SERVICE CORPORATION
AEP CIVIL ENGINEERING LABORATORY
 LOG OF BORING



JOB NUMBER _____

COMPANY **APPALACHIAN POWER COMPANY**

BORING NO. **MW-15** DATE **7/23/15** SHEET **2** OF **3**

PROJECT **MOUNTAINEER LBR LANDFILL**

BORING START **7/13/92** BORING FINISH **7/22/92**

SAMPLE NUMBER	SAMPLE	SAMPLE DEPTH IN FEET		STANDARD PENETRATION RESISTANCE BLOWS / 6"	TOTAL LENGTH RECOVERY	RQD	DEPTH IN FEET	GRAPHIC LOG	USCS	SOIL / ROCK IDENTIFICATION	WELL	DRILLER'S NOTES
		FROM	TO			%						
5	NQ-2	23.2	25.2		1.4	70	25					
6	NQ-2	25.2	29.6		3.2	34						
7	NQ-2	29.6	35.2		5.5	84	30			high angle fracture fracture at 29.2		
										GRAY CLAY SHALE		
8	NQ-2	35.2	45.2			74	35			GRAY CLAY SHALE hard		
							40			GRAY SANDSTONE		
										GRAY CLAY SHALE		
9	NQ-2	45.2	55.2		10.0	45	45			GRAY SANDSTONE hard		

38.7 Top of bentonite seal.

43.7 Top of gravel pack.

44.9 Top of screen.

AEP MT LBR LF FKA SI/GPJ AEP.GDT 7/23/15

Continued Next Page

AMERICAN ELECTRIC POWER SERVICE CORPORATION
AEP CIVIL ENGINEERING LABORATORY
 LOG OF BORING



JOB NUMBER _____

COMPANY **APPALACHIAN POWER COMPANY**

BORING NO. **MW-15** DATE **7/23/15** SHEET **3** OF **3**

PROJECT **MOUNTAINEER LBR LANDFILL**

BORING START **7/13/92** BORING FINISH **7/22/92**

SAMPLE NUMBER	SAMPLE	SAMPLE DEPTH IN FEET		STANDARD PENETRATION RESISTANCE BLOWS / 6"	TOTAL LENGTH RECOVERY	RQD	DEPTH IN FEET	GRAPHIC LOG	USCS	SOIL / ROCK IDENTIFICATION	WELL	DRILLER'S NOTES
		FROM	TO			%						
							50					
10	NQ-2	55.2	58.1		2.7		55			GRAY SANDY SHALE		53.9 Bottom of screen. 56.0 Bottom of gravel pack. 58.1 Bottom of boring.
<p>WELL DEVELOPMENT Hole was flushed with drill water until drill water was visually clear. Boring was bailed and a 2" monitoring well was installed and pumped until visually clear sample obtained. WELL MATERIAL 2"diameter 20 slot screen pvc. 2" diameter sch 80 pvc.</p>												

AMERICAN ELECTRIC POWER SERVICE CORPORATION
AEP CIVIL ENGINEERING LABORATORY
 LOG OF BORING



JOB NUMBER _____
 COMPANY **APPALACHIAN POWER COMPANY**
 PROJECT **MOUNTAINEER LBR LANDFILL**
 COORDINATES **N 714,546.9 E 1,733,259.1**
 GROUND ELEVATION **626.0** SYSTEM _____

BORING NO. **MW-16** DATE **7/23/15** SHEET **1** OF **2**
 BORING START **5/20/92** BORING FINISH **5/21/92**
 PIEZOMETER TYPE _____ WELL TYPE **OW**
 HGT. RISER ABOVE GROUND **2.75** DIA **2.0**
 DEPTH TO TOP OF WELL SCREEN **11.0** BOTTOM **21.45**
 WELL DEVELOPMENT **SEE NOTES** BACKFILL **BENTONITE**
 FIELD PARTY **HOWELL/YATES** RIG **CME-75**

Water Level, ft	▽ 16.0	▼	▼
TIME			
DATE	5-20-92		

SAMPLE NUMBER	SAMPLE	SAMPLE DEPTH IN FEET		STANDARD PENETRATION RESISTANCE BLOWS / 6"	TOTAL LENGTH RECOVERY	RQD %	DEPTH IN FEET	GRAPHIC LOG	USCS	SOIL / ROCK IDENTIFICATION	WELL	DRILLER'S NOTES
		FROM	TO									
1	SS	2.0	3.5	2-4-5-	1.2					BROWN AND GRAY CLAY with rock fragment		Volclay grout seal replaced with bentonite seal.
2	SS	7.0	8.5	2-3-4-	1.3		5			BROWN SANDY SILT moist		
3	SS	12.0	13.5	3-5-6	1.1		10					10.0 Top of gravel pack. 11.0 Top of screen.
4	SS	17.0	18.5	4-5-6-	1.2		15			GRAY CLAY moist		

TYPE OF CASING USED

<input type="checkbox"/>	NQ-2 ROCK CORE	
<input checked="" type="checkbox"/>	6" x 3.25 HSA	
<input type="checkbox"/>	9" x 6.25 HSA	
<input type="checkbox"/>	HW CASING ADVANCER	4"
<input type="checkbox"/>	NW CASING	3"
<input type="checkbox"/>	SW CASING	6"
<input type="checkbox"/>	AIR HAMMER	8"

Continued Next Page

PIEZOMETER TYPE: PT = OPEN TUBE POROUS TIP, SS = OPEN TUBE SLOTTED SCREEN, G = GEONOR, P = PNEUMATIC
 WELL TYPE: OW = OPEN TUBE SLOTTED SCREEN, GM = GEOMON

RECORDER _____

AEP_Mt.LBR.LF.FKA.SI.GPJ.AEP.GDT.7/23/15

AMERICAN ELECTRIC POWER SERVICE CORPORATION
AEP CIVIL ENGINEERING LABORATORY
 LOG OF BORING



JOB NUMBER _____

COMPANY **APPALACHIAN POWER COMPANY**

BORING NO. **MW-16** DATE **7/23/15** SHEET **2** OF **2**

PROJECT **MOUNTAINEER LBR LANDFILL**

BORING START **5/20/92** BORING FINISH **5/21/92**

SAMPLE NUMBER	SAMPLE	SAMPLE DEPTH IN FEET		STANDARD PENETRATION RESISTANCE BLOWS / 6"	TOTAL LENGTH RECOVERY	RQD	DEPTH IN FEET	GRAPHIC LOG	USCS	SOIL / ROCK IDENTIFICATION	WELL	DRILLER'S NOTES
		FROM	TO			%						
5	SS	22.0	23.5	3-7-8	1.1					GRAY SHALE moist cemented		21.4 Bottom of screen.
6	SS	27.0	28.5	4-7-12	1.3		25			RED SHALE		
<p>WELL DEVELOPMENT 6" casing was installed and flushed with drill water until visually clear and a 2" monitoring well installed. Boring was pumped and a sample was obtained. Sample obtained was turbid.</p> <p>WELL MATERIAL 2" diameter 20 slot screen pvc. 2" diameter sch. 40 pvc screen.</p>												28.5 Bottom of gravel pack and bottom of boring.

AMERICAN ELECTRIC POWER SERVICE CORPORATION
AEP CIVIL ENGINEERING LABORATORY
 LOG OF BORING



JOB NUMBER _____
 COMPANY **APPALACHIAN POWER COMPANY**
 PROJECT **MOUNTAINEER LBR LANDFILL**
 COORDINATES **N 714,833.5 E 1,733,260.6**
 GROUND ELEVATION **621.5** SYSTEM _____

BORING NO. **MW-17** DATE **7/23/15** SHEET **1** OF **2**
 BORING START **5/20/92** BORING FINISH **5/20/92**
 PIEZOMETER TYPE _____ WELL TYPE **OW**
 HGT. RISER ABOVE GROUND **1.82** DIA **2.0**
 DEPTH TO TOP OF WELL SCREEN **18.55** BOTTOM **28**
 WELL DEVELOPMENT **SEE NOTES** BACKFILL **VOLCLAY GROUT**
 FIELD PARTY **HOWELL/YATES** RIG **CME-75**

Water Level, ft	▽ 8.1	▼	▼
TIME			
DATE	5-20-92		

SAMPLE NUMBER	SAMPLE	SAMPLE DEPTH IN FEET		STANDARD PENETRATION RESISTANCE BLOWS / 6"	TOTAL LENGTH RECOVERY	RQD %	DEPTH IN FEET	GRAPHIC LOG	USCS	SOIL / ROCK IDENTIFICATION	WELL	DRILLER'S NOTES
		FROM	TO									
1	SS	2.4	3.9	4-9-12	1.1		5			RED AND BROWN CLAY		
2	SS	7.4	8.9	3-7-8	1.3		10			BROWN CLAY		
3	SS	12.4	13.9	2-2-4	1.4		15			BROWN SANDY SILT BROWN CLAY		12.0 Top of bentonite seal.
4	SS	17.4	18.9	2-3-5	1.2					BROWN SANDY CLAY wet GRAY CLAY		AUGER RETURN SATURATER BROWN SANDY SILT. 17.0 Top of gravel pack. 18.5 Top of screen.

TYPE OF CASING USED	
<input type="checkbox"/>	NQ-2 ROCK CORE
<input checked="" type="checkbox"/>	6" x 3.25 HSA
<input type="checkbox"/>	9" x 6.25 HSA
<input type="checkbox"/>	HW CASING ADVANCER 4"
<input type="checkbox"/>	NW CASING 3"
<input type="checkbox"/>	SW CASING 6"
<input type="checkbox"/>	AIR HAMMER 8"

Continued Next Page

PIEZOMETER TYPE: PT = OPEN TUBE POROUS TIP, SS = OPEN TUBE SLOTTED SCREEN, G = GEONOR, P = PNEUMATIC

WELL TYPE: OW = OPEN TUBE SLOTTED SCREEN, GM = GEOMON

RECORDER _____

AEP_Mt.LBR.LF.FKA.SI.GPJ.AEP.GDT.7/23/15

AMERICAN ELECTRIC POWER SERVICE CORPORATION
AEP CIVIL ENGINEERING LABORATORY
 LOG OF BORING



JOB NUMBER _____

COMPANY **APPALACHIAN POWER COMPANY**

BORING NO. **MW-17** DATE **7/23/15** SHEET **2** OF **2**

PROJECT **MOUNTAINEER LBR LANDFILL**

BORING START **5/20/92** BORING FINISH **5/20/92**

SAMPLE NUMBER	SAMPLE	SAMPLE DEPTH IN FEET		STANDARD PENETRATION RESISTANCE BLOWS / 6"	TOTAL LENGTH RECOVERY	RQD	DEPTH IN FEET	GRAPHIC LOG	USCS	SOIL / ROCK IDENTIFICATION	WELL	DRILLER'S NOTES
		FROM	TO			%						
5	SS	22.4	23.9	2-4-5	1.1					GRAY SILTY CLAY moist GRAY CLAY moist with rock fragment throughout		
6	SS	27.4	28.9	3-4-6	1.2		25			GRAY CLAY SHALE moist cemented		28.0 Bottom of screen.
7	SS	30.0	30.5	75/5	.5		30			TOP .4 GRAY CLAY SHALE BOTTOM .1 GRAY SHALE hard WELL DEVELOPMENT 6" diameter casing was installed and flushed with drill water was visually clear and a 2" diameter well installed. Well was pumped until a visually clear sample was obtained. WELL MATERIAL 2" diameter 20 slot screen pvc. 2" diameter sch. 40 pvc casing.		AUGER REFUSAL 30.5 Bottom of gravel pack and boring.

AMERICAN ELECTRIC POWER SERVICE CORPORATION
AEP CIVIL ENGINEERING LABORATORY
 LOG OF BORING



JOB NUMBER _____
 COMPANY **APPALACHIAN POWER COMPANY**
 PROJECT **MOUNTAINEER LBR LANDFILL**
 COORDINATES **N 714,922.0 E 1,733,257.8**
 GROUND ELEVATION **622.0** SYSTEM _____

BORING NO. **MW-18** DATE **7/23/15** SHEET **1** OF **2**
 BORING START **5/19/92** BORING FINISH **5/19/92**
 PIEZOMETER TYPE _____ WELL TYPE **OW**
 HGT. RISER ABOVE GROUND **1.83** DIA **2.0**
 DEPTH TO TOP OF WELL SCREEN **15.1** BOTTOM **24.2**
 WELL DEVELOPMENT **SEE NOTES** BACKFILL **VOLCLAY GROUT**
 FIELD PARTY **TJW/RLY** RIG **CME-75**

Water Level, ft	▽ 13.3	▼	▼
TIME			
DATE	5-19-92		

SAMPLE NUMBER	SAMPLE	SAMPLE DEPTH IN FEET		STANDARD PENETRATION RESISTANCE BLOWS / 6"	TOTAL LENGTH RECOVERY	RQD %	DEPTH IN FEET	GRAPHIC LOG	USCS	SOIL / ROCK IDENTIFICATION	WELL	DRILLER'S NOTES
		FROM	TO									
1.1	SS	2.4	3.9	9-10-12	1							
.8	SS	7.4	8.9	1-2-2	2		5					
1.0	SS	12.4	13.9	8-9-15	3		10					9.0 Top of bentonite seal.
1.1	SS	17.4	18.9	4-6-12	4		15					13.8 Top of gravel pack. 15.1 Top of screen.

TYPE OF CASING USED

<input checked="" type="checkbox"/>	NQ-2 ROCK CORE	
<input type="checkbox"/>	6" x 3.25 HSA	
<input type="checkbox"/>	9" x 6.25 HSA	
<input type="checkbox"/>	HW CASING ADVANCER	4"
<input type="checkbox"/>	NW CASING	3"
<input type="checkbox"/>	SW CASING	6"
<input type="checkbox"/>	AIR HAMMER	8"

Continued Next Page

PIEZOMETER TYPE: PT = OPEN TUBE POROUS TIP, SS = OPEN TUBE SLOTTED SCREEN, G = GEONOR, P = PNEUMATIC
 WELL TYPE: OW = OPEN TUBE SLOTTED SCREEN, GM = GEOMON

RECORDER _____

AEP_Mt.LBR.LF.FKA.SI.GPJ.AEP.GDT.7/23/15

AMERICAN ELECTRIC POWER SERVICE CORPORATION
AEP CIVIL ENGINEERING LABORATORY
 LOG OF BORING



JOB NUMBER _____

COMPANY **APPALACHIAN POWER COMPANY**

BORING NO. **MW-18** DATE **7/23/15** SHEET **2** OF **2**

PROJECT **MOUNTAINEER LBR LANDFILL**

BORING START **5/19/92** BORING FINISH **5/19/92**

SAMPLE NUMBER	SAMPLE	SAMPLE DEPTH IN FEET		STANDARD PENETRATION RESISTANCE BLOWS / 6"	TOTAL LENGTH RECOVERY	RQD	DEPTH IN FEET	GRAPHIC LOG	USCS	SOIL / ROCK IDENTIFICATION	WELL	DRILLER'S NOTES
		FROM	TO			%						
1.2	SS	22.4	23.9	4-8-12	5					RED CLAY with rock fragment, bottom of sample changes from red to a green/brown shaley		
1.0	SS	25.9	26.9	39-54	6		25			TOP .9 S-1 GREEN/BROWN CLAY SHALE BOTTOM .1 S-2 GRAY SHALE hard TOP .9 S-1 GREENISH/BROWN CLAY SHALE with rock fragment BOTTOM .1 S-2 HARD GRAY SHALE		24.2 Bottom of screen. 26.2 Bottom of gravel pack and boring.
<p>WELL DEVELOPMENT 6" casing was installed and flushed with drill water until drill water return visually clear and a 2" monitoring well was installed. Well was pumped until visually clear sample was obtained. WELL MATERIAL 2" diameter 20 slot screen pvc. 2" diameter sch. 40 pvc casing.</p>												
60												

AMERICAN ELECTRIC POWER SERVICE CORPORATION
AEP CIVIL ENGINEERING LABORATORY
 LOG OF BORING



JOB NUMBER _____
 COMPANY **APPALACHIAN POWER COMPANY**
 PROJECT **MOUNTAINEER LBR LANDFILL**
 COORDINATES **N 712,263.7 E 1,732,224.9**
 GROUND ELEVATION **643.2** SYSTEM _____

BORING NO. **MW-19** DATE **7/23/15** SHEET **1** OF **2**
 BORING START **8/12/92** BORING FINISH **8/13/92**
 PIEZOMETER TYPE _____ WELL TYPE **OW**
 HGT. RISER ABOVE GROUND **1.96** DIA **2.0**
 DEPTH TO TOP OF WELL SCREEN **11.6** BOTTOM **20.5**
 WELL DEVELOPMENT **SEE NOTES** BACKFILL **VOLCLAY GROUT**
 FIELD PARTY **TJH-TLS** RIG **CME-75**

Water Level, ft	▽ 2.7	▼	▼
TIME			
DATE	8-27-92		

SAMPLE NUMBER	SAMPLE	SAMPLE DEPTH IN FEET		STANDARD PENETRATION RESISTANCE BLOWS / 6"	TOTAL LENGTH RECOVERY	RQD %	DEPTH IN FEET	GRAPHIC LOG	USCS	SOIL / ROCK IDENTIFICATION	WELL	DRILLER'S NOTES
		FROM	TO									
										0 TO 8.0 FT. AUGERED BEFORE PERFORMING FIRST SAMPLE		Volclay grout seal was replaced with bentonite pellets.
1	SS	8.0	9.5	4-1-1	1.2		5			GRAY SANDY CLAY with wood fragment		
2	SS	9.5	11.0	1-1-1	.9		10					
3	SS	11.0	12.5	4-12-7	1.4					BROWN SANDY CLAY		10.5 Top of gravel pack.
4	SS	12.5	14.0	4-5-7	0					GRAY SANDY CLAY		11.6 Top of screen.
5	SS	14.0	15.5	3-2-3	.2					BROWN SILTY CLAY		
6	SS	15.5	17.0	2-2-2	1.5		15					
7	SS	17.0	18.5	1-1-1								
8	SS	18.5	20.0	1-2-2						BROWN AND GRAY CLAYEY SAND BROWN AND GRAY SANDY CLAY with .2'sand lens		

TYPE OF CASING USED

	NQ-2 ROCK CORE	
	6" x 3.25 HSA	
	9" x 6.25 HSA	
	HW CASING ADVANCER	4"
	NW CASING	3"
X	SW CASING	6"
	AIR HAMMER	8"

Continued Next Page

PIEZOMETER TYPE: PT = OPEN TUBE POROUS TIP, SS = OPEN TUBE SLOTTED SCREEN, G = GEONOR, P = PNEUMATIC
 WELL TYPE: OW = OPEN TUBE SLOTTED SCREEN, GM = GEOMON

RECORDER _____

AMERICAN ELECTRIC POWER SERVICE CORPORATION
AEP CIVIL ENGINEERING LABORATORY
 LOG OF BORING



JOB NUMBER _____

COMPANY **APPALACHIAN POWER COMPANY**

BORING NO. **MW-19** DATE **7/23/15** SHEET **2** OF **2**

PROJECT **MOUNTAINEER LBR LANDFILL**

BORING START **8/12/92** BORING FINISH **8/13/92**

SAMPLE NUMBER	SAMPLE	SAMPLE DEPTH IN FEET		STANDARD PENETRATION RESISTANCE BLOWS / 6"	TOTAL LENGTH RECOVERY	RQD	DEPTH IN FEET	GRAPHIC LOG	USCS	SOIL / ROCK IDENTIFICATION	WELL	DRILLER'S NOTES
		FROM	TO			%						
9	SS	20.0	21.3	2-2-50/2						BROWN AND GRAY SANDY CLAY with sandstone fragment		20.5 Bottom of screen.
										AUGER REFUSAL		22.8 Bottom of gravel pack and boring.
										WELL DEVELOPMENT 6" casing was installed and flushed with drill water until drill water was visually clear and a 2" diameter well installed and pumped until a visually clear sample was obtained. WELL MATERIAL 2" diameter 20 slot screen pvc. 2" diameter sch. 40 pvc casing.		

AMERICAN ELECTRIC POWER SERVICE CORPORATION
AEP CIVIL ENGINEERING LABORATORY
 LOG OF BORING



JOB NUMBER _____
 COMPANY **APPALACHIAN POWER COMPANY**
 PROJECT **MOUNTAINEER LBR LANDFILL**
 COORDINATES **N 710,956.1 E 1,730,893.8**
 GROUND ELEVATION **680.0** SYSTEM _____

BORING NO. **MW-20** DATE **7/23/15** SHEET **1** OF **2**
 BORING START **8/18/92** BORING FINISH **8/18/92**
 PIEZOMETER TYPE _____ WELL TYPE **OW**
 HGT. RISER ABOVE GROUND **2.03** DIA **2.0**
 DEPTH TO TOP OF WELL SCREEN **8.9** BOTTOM **17.9**
 WELL DEVELOPMENT **SEE NOTES** BACKFILL **BENTONITE**
 FIELD PARTY **TJH-TLS** RIG **CME-75**

Water Level, ft	<input type="checkbox"/>	<input type="checkbox"/>	<input type="checkbox"/>
TIME			
DATE			

SAMPLE NUMBER	SAMPLE	SAMPLE DEPTH IN FEET		STANDARD PENETRATION RESISTANCE BLOWS / 6"	TOTAL LENGTH RECOVERY	RQD %	DEPTH IN FEET	GRAPHIC LOG	USCS	SOIL / ROCK IDENTIFICATION	WELL	DRILLER'S NOTES	
		FROM	TO										
							5					Volclay grout seal was replaced with bentonite pellets.	
							10						7.9 Top of gravel pack. 8.9 Top of screen.
NQ-2		13.9	20.5		6.6	60	15						17.9 Bottom of screen.
										BROWN SANDY SHALE			
										GRAY SANDSTONE hard			
										GRAY SHALE hard			

TYPE OF CASING USED

	NQ-2 ROCK CORE	
X	6" x 3.25 HSA	
	9" x 6.25 HSA	
	HW CASING ADVANCER	4"
	NW CASING	3"
X	SW CASING	6"
	AIR HAMMER	8"

Continued Next Page

PIEZOMETER TYPE: PT = OPEN TUBE POROUS TIP, SS = OPEN TUBE SLOTTED SCREEN, G = GEONOR, P = PNEUMATIC
 WELL TYPE: OW = OPEN TUBE SLOTTED SCREEN, GM = GEOMON

RECORDER _____

AMERICAN ELECTRIC POWER SERVICE CORPORATION
AEP CIVIL ENGINEERING LABORATORY
 LOG OF BORING



JOB NUMBER _____

COMPANY **APPALACHIAN POWER COMPANY**

BORING NO. **MW-20** DATE **7/23/15** SHEET **2** OF **2**

PROJECT **MOUNTAINEER LBR LANDFILL**

BORING START **8/18/92** BORING FINISH **8/18/92**

SAMPLE NUMBER	SAMPLE	SAMPLE DEPTH IN FEET		STANDARD PENETRATION RESISTANCE BLOWS / 6"	TOTAL LENGTH RECOVERY	RQD	DEPTH IN FEET	GRAPHIC LOG	USCS	SOIL / ROCK IDENTIFICATION	WELL	DRILLER'S NOTES
		FROM	TO			%						
												20.5 Bottom of gravel pack and boring.
										WELL DEVELOPMENT 6" CASING WAS INSTALLED AND FLUSHED WITH DRILL WATER UNTIL DRILL WATER APPEARED VISUALLY CLEAN. A 2" DIAMETER WELL WAS INSTALLED AND PUMPED UNTIL VISUALLY CLEAR AND A SAMPLE OBTAINED. WELL MATERIAL 2" diameter 20 slot screen pvc. 2" diameter sch 80 pvc casing.		

AMERICAN ELECTRIC POWER SERVICE CORPORATION
AEP CIVIL ENGINEERING LABORATORY
 LOG OF BORING



JOB NUMBER _____
 COMPANY **APPALACHIAN POWER COMPANY**
 PROJECT **MOUNTAINEER LBR LANDFILL**
 COORDINATES **N 710,790.4 E 1,730,872.3**
 GROUND ELEVATION **674.9** SYSTEM _____

BORING NO. **MW-21** DATE **7/23/15** SHEET **1** OF **1**
 BORING START **9/2/92** BORING FINISH **9/2/92**
 PIEZOMETER TYPE _____ WELL TYPE _____
 HGT. RISER ABOVE GROUND _____ DIA _____
 DEPTH TO TOP OF WELL SCREEN _____ BOTTOM _____
 WELL DEVELOPMENT _____ BACKFILL **VOLCLAY**
 FIELD PARTY **TJH-TLS** RIG **CME-75**

Water Level, ft	<input type="checkbox"/>	<input type="checkbox"/>	<input type="checkbox"/>
TIME			
DATE			

SAMPLE NUMBER	SAMPLE	SAMPLE DEPTH IN FEET		STANDARD PENETRATION RESISTANCE BLOWS / 6"	TOTAL LENGTH RECOVERY	RQD %	DEPTH IN FEET	GRAPHIC LOG	USCS	SOIL / ROCK IDENTIFICATION	WELL	DRILLER'S NOTES
		FROM	TO									
										AUGERED TO 8.0 BEFORE FIRST SPT		
1	SS	8.0	9.5	5-8-9	1.5		5			BROWN SILTY CLAY with sandstone fragment		
2	SS	9.5	11.0	8-13-15	1.3		10			RED SILTY CLAY with sandstone fragment		
3	SS	11.0	12.5	7-8-11	.8							
4	SS	12.5	14.0	5-7-11	.7					RED CLAY		
5	SS	14.0	15.5	3-4-7	1.1					BROWN SANDSTONE weathered		
							15			RED CLAY		
6	SS	15.5	17.0	4-12-21	1.5					GREEN SANDSTONE weathered		
										RED CLAY SHALE weathered		
7	SS	17.0	17.9	22/50.4	.6					BROWN AND PURPLE CLAY SHALE weathered		

TYPE OF CASING USED		PIEZOMETER TYPE: PT = OPEN TUBE POROUS TIP, SS = OPEN TUBE SLOTTED SCREEN, G = GEONOR, P = PNEUMATIC
<input checked="" type="checkbox"/>	NQ-2 ROCK CORE	
<input type="checkbox"/>	6" x 3.25 HSA	WELL TYPE: OW = OPEN TUBE SLOTTED SCREEN, GM = GEOMON
<input type="checkbox"/>	9" x 6.25 HSA	
<input type="checkbox"/>	HW CASING ADVANCER 4"	RECORDER _____
<input type="checkbox"/>	NW CASING 3"	
<input type="checkbox"/>	SW CASING 6"	
<input type="checkbox"/>	AIR HAMMER 8"	

AEP_Mt_LBR_LF_FKA_SiGPU_AEP_GDT_7/23/15

AMERICAN ELECTRIC POWER SERVICE CORPORATION
AEP CIVIL ENGINEERING LABORATORY
 LOG OF BORING



JOB NUMBER _____
 COMPANY **APPALACHIAN POWER COMPANY**
 PROJECT **MOUNTAINEER LBR LANDFILL**
 COORDINATES **N 714,609.8 E 1,733,558.2**
 GROUND ELEVATION **636.6** SYSTEM State Plane using NAD27/29

BORING NO. **MW-43** DATE **7/23/15** SHEET **1** OF **3**
 BORING START **7/10/06** BORING FINISH **7/12/06**
 PIEZOMETER TYPE **N/A** WELL TYPE **OW**
 HGT. RISER ABOVE GROUND **3.5** DIA **2"**
 DEPTH TO TOP OF WELL SCREEN **10.9** BOTTOM **29.7**
 WELL DEVELOPMENT **Yes/Reclaimer** BACKFILL **Quick Grout**
 FIELD PARTY **MCR / ZLR** RIG **D-120**

Water Level, ft	<input type="checkbox"/>	<input type="checkbox"/>	<input type="checkbox"/>
TIME			
DATE			

SAMPLE NUMBER	SAMPLE	SAMPLE DEPTH IN FEET		STANDARD PENETRATION RESISTANCE BLOWS / 6"	TOTAL LENGTH RECOVERY	RQD %	DEPTH IN FEET	GRAPHIC LOG	USCS	SOIL / ROCK IDENTIFICATION	WELL	DRILLER'S NOTES
		FROM	TO									
0	AUGER	0.0	3.5							AUGER		GROUNDING PROCEDURE NOT IN USE ON THIS BORING DIGGING PERMIT REQUIRED DECONNED ALL TOOLS USING MOUNTAINEER FIRE PROTECTION WATER AND LIQUI-NOX
1	SPT	3.5	5.0	10-4-3	.6		5			LOOSE 5YR 3/4 MODERATE BROWN MEDIUM SAND w/little clay & sandstone frag, dry		
2	SPT	8.5	10.0	3-4-5	1.5		10			STIFF 5YR 4/4 MODERATE BROWN CLAY 1.25 tsf, w/trace fine sand, dry		
3	SPT	13.5	15.0	7-9-13	1.2		15			STIFF 5YR 4/4 MODERATE BROWN CLAY 3.0 tsf, w/trace fine sand, dry		
4	SPT	18.5	20.0	17-11-50/.2	1.0					HARD 5YR 6/4 LIGHT BROWN CLAY 2.5 tsf, w/some medium sand, dry		

TYPE OF CASING USED

	NQ-2 ROCK CORE
	6" x 3.25 HSA
	9" x 6.25 HSA
	HW CASING ADVANCER 4"
	NW CASING 3"
	SW CASING 6"
	AIR HAMMER 8"

Continued Next Page

PIEZOMETER TYPE: PT = OPEN TUBE POROUS TIP, SS = OPEN TUBE SLOTTED SCREEN, G = GEONOR, P = PNEUMATIC
 WELL TYPE: OW = OPEN TUBE SLOTTED SCREEN, GM = GEOMON

RECORDER **MCR**

AMERICAN ELECTRIC POWER SERVICE CORPORATION
AEP CIVIL ENGINEERING LABORATORY
 LOG OF BORING



JOB NUMBER _____

COMPANY **APPALACHIAN POWER COMPANY**

BORING NO. **MW-43** DATE **7/23/15** SHEET **2** OF **3**

PROJECT **MOUNTAINEER LBR LANDFILL**

BORING START **7/10/06** BORING FINISH **7/12/06**

SAMPLE NUMBER	SAMPLE	SAMPLE DEPTH IN FEET		STANDARD PENETRATION RESISTANCE BLOWS / 6"	TOTAL LENGTH RECOVERY	RQD	DEPTH IN FEET	GRAPHIC LOG	USCS	SOIL / ROCK IDENTIFICATION	WELL	DRILLER'S NOTES
		FROM	TO			%						
5	SPT	23.5	23.9	50/.4	.3		25			HARD 5G 5/2 DUSKY YELLOW GREEN WEATHERED FINE GRAIN SANDY SHALE dry		
6	SPT	28.5	29.2	30-50/.2	.7		30			HARD 5YR 3/4 MODERATE BROWN CLAY SHALE dry		
7	SPT	30.8	31.0	50/.2	.2	59				HARD 5G 4/1 DARK GREENISH GRAY CLAY SHALE dry		STOPPED CASING ADVANCER @ 30.8' STARTED CORING @ 31.0'
1	NQ	31.0	34.5		2.7					MEDIUM HARD 5G 4/1 DARK GREENISH GRAY CLAY SHALE		
2	NQ	34.5	44.5		6.5	22	35			VERY SOFT 10R 5/4 PALE REDDISH BROWN CLAY SHALE		
							40					
3	NQ	44.5	49.5		5.0	62	45			HARD 5B 7/1 LIGHT BLUISH GRAY SILTY CLAY SHALE .1 soft area @ 48.3'		

AEP MT LBR LF FKA SJ/GPJ AEP.GDT 7/23/15

Continued Next Page

AMERICAN ELECTRIC POWER SERVICE CORPORATION
AEP CIVIL ENGINEERING LABORATORY
 LOG OF BORING



JOB NUMBER _____

COMPANY **APPALACHIAN POWER COMPANY**

BORING NO. **MW-43** DATE **7/23/15** SHEET **3** OF **3**

PROJECT **MOUNTAINEER LBR LANDFILL**

BORING START **7/10/06** BORING FINISH **7/12/06**

SAMPLE NUMBER	SAMPLE	SAMPLE DEPTH IN FEET		STANDARD PENETRATION RESISTANCE BLOWS / 6"	TOTAL LENGTH RECOVERY	RQD	DEPTH IN FEET	GRAPHIC LOG	USCS	SOIL / ROCK IDENTIFICATION	WELL	DRILLER'S NOTES
		FROM	TO			%						
												STOPPED BORING @ 49.5' PLUGGED NQ ROCK HOLE W/BENTONITE PELLETS PULLED HW CASING & REDRILLED SAME BORE HOLE W/6.25" HSA'S TO SET 2" WELL

AMERICAN ELECTRIC POWER SERVICE CORPORATION
AEP CIVIL ENGINEERING LABORATORY
 LOG OF BORING



JOB NUMBER _____
 COMPANY **APPALACHIAN POWER COMPANY**
 PROJECT **MOUNTAINEER LBR LANDFILL**
 COORDINATES **N 714,697.9 E 1,733,351.5**
 GROUND ELEVATION **624.5** SYSTEM State Plane using NAD27

BORING NO. **MW-44** DATE **7/23/15** SHEET **1** OF **2**
 BORING START **6/10/08** BORING FINISH **6/10/08**
 PIEZOMETER TYPE _____ WELL TYPE _____
 HGT. RISER ABOVE GROUND **2.642** DIA _____
 DEPTH TO TOP OF WELL SCREEN _____ BOTTOM _____
 WELL DEVELOPMENT **N/A** BACKFILL **Quick Grout**
 FIELD PARTY **MCR / ZLR / RMP** RIG **D-120**

Water Level, ft	<input type="checkbox"/>	<input type="checkbox"/>	<input type="checkbox"/>
TIME			
DATE			

SAMPLE NUMBER	SAMPLE	SAMPLE DEPTH IN FEET		STANDARD PENETRATION RESISTANCE BLOWS / 6"	TOTAL LENGTH RECOVERY	RQD %	DEPTH IN FEET	GRAPHIC LOG	USCS	SOIL / ROCK IDENTIFICATION	WELL	DRILLER'S NOTES
		FROM	TO									
1	SPT	0.0	1.5	3-4-7	1.5					STIFF 10R 3/4 DARK REDDISH BROWN CLAY tsf 4.5, w/trace of silts and trace of weathered coal, dry		NO GROUNDING PROCEDURE IN USE ON THIS BORING; DIGGING PERMIT IN HAND
2	SPT	1.5	3.0	4-7-10	1.5					STIFF 10R 3/4 DARK REDDISH BROWN CLAY tsf 4.0, w/trace of silts, dry		
3	SPT	3.0	4.5	3-4-7	1.5					STIFF 10R 5/4 PALE REDDISH BROWN CLAY tsf 3.75, w/trace of silts and trace of weathered coal, dry		
4	SPT	4.5	6.0	3-4-6	1.5		5			STIFF 10R 5/4 PALE REDDISH BROWN CLAY tsf 3.0, w/ little silt, dry		
5	SPT	6.0	7.5	4-7-12	1.5					STIFF 10YR 6/6 DARK YELLOWISH ORANGE CLAY tsf 2.5, w/some sand and weathered fine grain sandstone and coal, dry		
6	SPT	7.5	9.0	7-4-6	1.4					STIFF 10YR 6/6 DARK YELLOWISH ORANGE CLAY tsf 2.0, w/some sand and weather fine grain sandstone and coal, .2' medium grain sand at bottom of spoon, moist		
7	SPT	9.0	10.5	5-4-5	1.5		10			STIFF 10YR 6/6 DARK YELLOWISH ORANGE CLAY AND SAND tsf 1.75, coarse w/sandstone and coal fragments, wet - water on outside of spoon		
8	SPT	10.5	12.0	3-5-7	1.5					STIFF 5 YR 6/4 LIGHT BROWN CLAY tsf 2.25, dry		
9	SPT	12.0	13.5	4-5-9	1.5					STIFF 10YR 6/6 DARK YELLOWISH ORANGE CLAY tsf 3.25, w/ little fine sand, moist		
10	SPT	13.5	15.0	7-7-11	1.5		15			STIFF 10R 6/6 DARK YELLOWISH ORANGE CLAY tsf 3.75, w/some coarse sand w/sandstone fragments, moist		
11	SPT	15.0	16.5	6-7-11	1.5					STIFF N5 MEDIUM GRAY CLAY tsf 2.5, w/ 2" silt seam, dry		
12	SPT	16.5	18.0	3-5-7	1.5					STIFF N6 MEDIUM LIGHT GRAY CLAY tsf 1.5, w/some silts, dry		
13	SPT	18.0	19.5	3-4-6	1.4					STIFF N6 MEDIUM LIGHT GRAY CLAYEY SILT tsf 1.5, dry to moist		
14	SPT	19.5	21.0	3-5-7	1.3							

TYPE OF CASING USED

Continued Next Page

	NQ-2 ROCK CORE	
	6" x 3.25 HSA	
	9" x 6.25 HSA	
	HW CASING ADVANCER	4"
	NW CASING	3"
	SW CASING	6"
	AIR HAMMER	8"

PIEZOMETER TYPE: PT = OPEN TUBE POROUS TIP, SS = OPEN TUBE SLOTTED SCREEN, G = GEONOR, P = PNEUMATIC
 WELL TYPE: OW = OPEN TUBE SLOTTED SCREEN, GM = GEOMON

RECORDER _____

AEP_Mt.LBR.LF.FKA.SI.GPJ.AEP.GDT.7/23/15

AMERICAN ELECTRIC POWER SERVICE CORPORATION
AEP CIVIL ENGINEERING LABORATORY
 LOG OF BORING



JOB NUMBER _____

COMPANY **APPALACHIAN POWER COMPANY**

BORING NO. **MW-44** DATE **7/23/15** SHEET **2** OF **2**

PROJECT **MOUNTAINEER LBR LANDFILL**

BORING START **6/10/08** BORING FINISH **6/10/08**

SAMPLE NUMBER	SAMPLE	SAMPLE DEPTH IN FEET		STANDARD PENETRATION RESISTANCE BLOWS / 6"	TOTAL LENGTH RECOVERY	RQD	DEPTH IN FEET	GRAPHIC LOG	USCS	SOIL / ROCK IDENTIFICATION	WELL	DRILLER'S NOTES
		FROM	TO			%						
15	SPT	21.0	22.5	4-6-12	1.5					STIFF N6 MEDIUM LIGHT GRAY CLAYEY SILT tsf 1.75, w/little medium sand w/sandstone fragments, moist		
16	SPT	22.5	24.0	4-12-16	1.4					VERY STIFF N6 MEDIUM LIGHT GRAY SILTY CLAY tsf 1.75, w/some medium sand and sandstone fragments, wet		
17	SPT	24.0	25.5	7-21-34	1.5					VERY STIFF 10YR 4/6 MEDIUM REDDISH BROWN CLAY tsf 1.75, w/little silts, dry to moist		
18	SPT	25.5	27.0	16-36-50/3	1.4		25			VERY STIFF N6 MEDIUM LIGHT GRAY SILTY CLAY tsf 1.25, w/trace of fine sand and rock fragments, wet		
19	SPT	27.0	28.5	20-38-50/2	1.1					SOFT 5R 3/4 DUSKY RED SILT tsf 1.25, dry		
										VERY STIFF 5R 6/2 PALE RED CLAY tsf 2.25, w/trace of fine sand, wet		STOPPED BORING @ 28.1', TREMIE GROUTED 28.1' TO GRADE USING 50 GALLONS OF QUICK GROUT; SWL 06/12/08 = 4.8', 16 hr READING
										SOFT 5R 3/4 DUSKY RED SILT tsf 2.25, dry		
										VERY STIFF 5R 4/2 GRAYISH RED WEATHERED CLAYSHALE tsf 4.5, dry		
										VERY STIFF 5R 4/2 GRAYISH RED WEATHERED CLAYSHALE tsf 3.25, dry		
										VERY STIFF N7 LIGHT GRAY WEATHERED CLAYSHALE tsf 3.25, dry		



AEP 1996, 1997

Boring Logs

96-21 to 96-24, 96-27 to 96-33

AMERICAN ELECTRIC POWER SERVICE CORPORATION
AEP CIVIL ENGINEERING LABORATORY
 LOG OF BORING



JOB NUMBER _____
 COMPANY **APPALACHIAN POWER COMPANY**
 PROJECT **MOUNTAINEER LBR LANDFILL**
 COORDINATES **N 711,473.4 E 1,700,163.8**
 GROUND ELEVATION **658.0** SYSTEM _____

BORING NO. **96-21** DATE **7/23/15** SHEET **1** OF **3**
 BORING START **9/17/96** BORING FINISH **9/18/96**
 PIEZOMETER TYPE _____ WELL TYPE **OW**
 HGT. RISER ABOVE GROUND **1.9** DIA **2.0**
 DEPTH TO TOP OF WELL SCREEN **26.0** BOTTOM **35.0**
 WELL DEVELOPMENT **YES** BACKFILL **QUICK GROUT**
 FIELD PARTY **MCR-LD** RIG **BK-81**

Water Level, ft	<input type="checkbox"/>	<input type="checkbox"/>	<input type="checkbox"/>
TIME			
DATE			

SAMPLE NUMBER	SAMPLE	SAMPLE DEPTH IN FEET		STANDARD PENETRATION RESISTANCE BLOWS / 6"	TOTAL LENGTH RECOVERY	RQD %	DEPTH IN FEET	GRAPHIC LOG	USCS	SOIL / ROCK IDENTIFICATION	WELL	DRILLER'S NOTES
		FROM	TO									
1	SS	0.0	1.5	1-1-2	1.0				CL	BROWN SANDY CLAY Fine grain.		Flushed boring with approximately 500 gallons of water. Rig was decon 1-23-97 potable water and Alconax. Hole drilled with HSA.
2	SS	1.5	3.0	4-4-4	1.2							
3	SS	3.0	5.0	5-5-7-8	1.5							
4	SS	5.0	7.0	4-6-8-10	1.5		5		CL	REDDISH BROWN CLAY With small sandstone gravels.		
5	ST	7.0	9.0		1.3				CL	TAN SILTY CLAY PUSH 2.0 PSI 1000 TIME 8 SEC.		
6	SS	9.0	11.0	5-8-11-15			10		CL	REDDISH BROWN CLAY With sandstone gravels.		
7	SS	11.0	13.0	4-6-7-8	1.5				CL	REDDISH GRAY SANDY CLAY		
8	SS	13.0	15.0	3-3-5	1.5							
9	ST	15.0	16.5		1.3		15			REDDISH TAN CLAYSHALE PUSH 1.5 TIME 10 SEC. PSI 1200 UNTIL LIFTED RIG		
10	SS	17.0	17.7	40-50/.2	.6					GRAY SILTY CLAYSHALE MEDIUM GRAY N5 CLAYSHALE With some fractures FE stains, 19.8 vertical fracture to 20.0'.		
11	NQ	19.1	25.0		5.9	19					18.3 Top of seal.	

TYPE OF CASING USED	
X	NQ-2 ROCK CORE
	6" x 3.25 HSA
	9" x 6.25 HSA
	HW CASING ADVANCER 4"
	NW CASING 3"
	SW CASING 6"
	AIR HAMMER 8"

Continued Next Page

PIEZOMETER TYPE: PT = OPEN TUBE POROUS TIP, SS = OPEN TUBE SLOTTED SCREEN, G = GEONOR, P = PNEUMATIC

WELL TYPE: OW = OPEN TUBE SLOTTED SCREEN, GM = GEOMON

RECORDER **LD**

AEP_Mt.LBR.LF.FKA.SI.GPJ.AEP.GDT.7/23/15

AMERICAN ELECTRIC POWER SERVICE CORPORATION
AEP CIVIL ENGINEERING LABORATORY
 LOG OF BORING



JOB NUMBER _____

COMPANY **APPALACHIAN POWER COMPANY**

BORING NO. **96-21** DATE **7/23/15** SHEET **2** OF **3**

PROJECT **MOUNTAINEER LBR LANDFILL**

BORING START **9/17/96** BORING FINISH **9/18/96**

SAMPLE NUMBER	SAMPLE	SAMPLE DEPTH IN FEET		STANDARD PENETRATION RESISTANCE BLOWS / 6"	TOTAL LENGTH RECOVERY	RQD	DEPTH IN FEET	GRAPHIC LOG	USCS	SOIL / ROCK IDENTIFICATION	WELL	DRILLER'S NOTES
		FROM	TO			%						
										20.4 to 22.8' clay seams.		
12	NQ	25.0	35.0		9.9	56	25			MEDIUM GRAY N-5 SANDSTONE With cross bedding, 26.0 leisingang staining on rock 26.0 to 26.2.		24.0 Top of sand. 26.0 Top of screen.
							30					
13	NQ	35.0	40.0		5.0	68	35			MEDIUM GRAY N-5 CLAYSHALE		35.0 Bottom of screen.
							36.1			GRAYISH RED 10R 4/2 CLAYSHALE		36.1 Bottom of sand.
							40					
										1-30-97 SWL 7.5. pH COND. TEMP. GALLONS SWL. 8.66 652 56 2.0 9.3. 8.17 633 56 6.0 12.8. 7.83 661 56 10.0 14.8. 8.42 653 56 12.0 16.0. 9.02 653 56 12.0 16.9. 8.98 644 56 12.0 17.5. 8.95 616 56 20.0 21.1. 8.88 666 56 20.0 24.1. 8.94 645 56 20.0 26.2. 9.07 642 56 60.0 29.7. 9.11 651 56 60.0 33.8.		

AEP MT LBR LF FKA SI/GPJ AEP.GDT 7/23/15

Continued Next Page

AMERICAN ELECTRIC POWER SERVICE CORPORATION
AEP CIVIL ENGINEERING LABORATORY
 LOG OF BORING



JOB NUMBER _____

COMPANY **APPALACHIAN POWER COMPANY**

BORING NO. **96-21** DATE **7/23/15** SHEET **3** OF **3**

PROJECT **MOUNTAINEER LBR LANDFILL**

BORING START **9/17/96** BORING FINISH **9/18/96**

SAMPLE NUMBER	SAMPLE	SAMPLE DEPTH IN FEET		STANDARD PENETRATION RESISTANCE BLOWS / 6"	TOTAL LENGTH RECOVERY	RQD	DEPTH IN FEET	GRAPHIC LOG	USCS	SOIL / ROCK IDENTIFICATION	WELL	DRILLER'S NOTES
		FROM	TO			%						
										STOPPED PUMP 2:19 SWL AT 2:29 12.9'. SWL 2-6-97 6.16'.		

AMERICAN ELECTRIC POWER SERVICE CORPORATION
AEP CIVIL ENGINEERING LABORATORY
 LOG OF BORING



JOB NUMBER _____
 COMPANY **APPALACHIAN POWER COMPANY**
 PROJECT **MOUNTAINEER LBR LANDFILL**
 COORDINATES **N 710,351.2 E 1,699,713.8**
 GROUND ELEVATION **803.1** SYSTEM _____

BORING NO. **96-22** DATE **7/23/15** SHEET **1** OF **10**
 BORING START **9/4/96** BORING FINISH **9/6/96**
 PIEZOMETER TYPE _____ WELL TYPE **OW**
 HGT. RISER ABOVE GROUND **1.68** DIA **2.0**
 DEPTH TO TOP OF WELL SCREEN **163.0** BOTTOM **292.0**
 WELL DEVELOPMENT **YES** BACKFILL **QUICK GROUT**
 FIELD PARTY **REB-RLY** RIG **JOY 22**

Water Level, ft	<input type="checkbox"/>	<input type="checkbox"/>	<input type="checkbox"/>
TIME			
DATE			

SAMPLE NUMBER	SAMPLE	SAMPLE DEPTH IN FEET		STANDARD PENETRATION RESISTANCE BLOWS / 6"	TOTAL LENGTH RECOVERY	RQD %	DEPTH IN FEET	GRAPHIC LOG	USCS	SOIL / ROCK IDENTIFICATION	WELL	DRILLER'S NOTES
		FROM	TO									
							5					Rig and tools decon 11-14-96 with potable water and Alconox. 11-19-96 Advance boring to 160, blown dry, 11-20-96 14 hrs 18'. 11-20-96 Completed hole blown dry, water returning about 2-3 gpm
1	NQ	8.5	20.2		11.7	34	10			BROWN SANDY CLAYSHALE With red oxidation throughout.		
							15					

TYPE OF CASING USED				<i>Continued Next Page</i>								
X	NQ-2 ROCK CORE			PIEZOMETER TYPE: PT = OPEN TUBE POROUS TIP, SS = OPEN TUBE SLOTTED SCREEN, G = GEONOR, P = PNEUMATIC								
	6" x 3.25 HSA			WELL TYPE: OW = OPEN TUBE SLOTTED SCREEN, GM = GEOMON								
	9" x 6.25 HSA			RECORDER RLY								
	HW CASING ADVANCER 4"											
	NW CASING 3"											
	SW CASING 6"											
	AIR HAMMER 8"											

AEP_Mt.LBR.LF.FKA.SI.GPJ.AEP.GDT.7/23/15

AMERICAN ELECTRIC POWER SERVICE CORPORATION
AEP CIVIL ENGINEERING LABORATORY
 LOG OF BORING



JOB NUMBER _____

COMPANY **APPALACHIAN POWER COMPANY**

BORING NO. **96-22** DATE **7/23/15** SHEET **2** OF **10**

PROJECT **MOUNTAINEER LBR LANDFILL**

BORING START **9/4/96** BORING FINISH **9/6/96**

SAMPLE NUMBER	SAMPLE	SAMPLE DEPTH IN FEET		STANDARD PENETRATION RESISTANCE BLOWS / 6"	TOTAL LENGTH RECOVERY	RQD	DEPTH IN FEET	GRAPHIC LOG	USCS	SOIL / ROCK IDENTIFICATION	WELL	DRILLER'S NOTES
		FROM	TO			%						
2	NQ	20.2	30.2		7.6	62				GRAY SANDY SHALE		
							25			BROWNISH GRAY CLAYSTONE		
3	NQ	30.2	40.2		8.8	73	30			RED CLAYSHALE		
							35			GRAY CLAYSHALE Hard with limestone nodules.		
4	NQ	40.2	50.2		10.0	79	40			Well cemented		
							45					

AEP MT LBR LF FKA SI/GPJ AEP.GDT 7/23/15

Continued Next Page

AMERICAN ELECTRIC POWER SERVICE CORPORATION
AEP CIVIL ENGINEERING LABORATORY
 LOG OF BORING



JOB NUMBER _____

COMPANY **APPALACHIAN POWER COMPANY**

BORING NO. **96-22** DATE **7/23/15** SHEET **3** OF **10**

PROJECT **MOUNTAINEER LBR LANDFILL**

BORING START **9/4/96** BORING FINISH **9/6/96**

SAMPLE NUMBER	SAMPLE	SAMPLE DEPTH IN FEET		STANDARD PENETRATION RESISTANCE BLOWS / 6"	TOTAL LENGTH RECOVERY	RQD	DEPTH IN FEET	GRAPHIC LOG	USCS	SOIL / ROCK IDENTIFICATION	WELL	DRILLER'S NOTES
		FROM	TO			%						
5	NQ	50.2	60.2		10.0	80	50			GRAY SANDY SHALE Well cemented.		
							55			GRAY CLAYSHALE		
6	NQ	60.2	70.2		10.0	90	60			OLIVE BROWN SANDY SHALE		
							65			GRAY CLAYSHALE		
7	NQ	70.2	80.2		10.0	64	70			GRAY CLAY 70.2-70.4 GRAY SANDY SHALE		

AEP_Mt_LBR_LF_FKA_Si_GPJ_AEP_GDT_7/23/15

Continued Next Page

AMERICAN ELECTRIC POWER SERVICE CORPORATION
AEP CIVIL ENGINEERING LABORATORY
 LOG OF BORING



JOB NUMBER _____

COMPANY **APPALACHIAN POWER COMPANY**

BORING NO. **96-22** DATE **7/23/15** SHEET **4** OF **10**

PROJECT **MOUNTAINEER LBR LANDFILL**

BORING START **9/4/96** BORING FINISH **9/6/96**

SAMPLE NUMBER	SAMPLE	SAMPLE DEPTH IN FEET		STANDARD PENETRATION RESISTANCE BLOWS / 6"	TOTAL LENGTH RECOVERY	RQD	DEPTH IN FEET	GRAPHIC LOG	USCS	SOIL / ROCK IDENTIFICATION	WELL	DRILLER'S NOTES
		FROM	TO			%						
							75					
8	NQ	80.2	90.2		10.0	90	80			GRAY SANDSTONE Well cemented.		
							85			RED CLAYSHALE		
9	NQ	90.2	100.2		10.0	100	90			GRAY SANDY SHALE Well cemented, limestone nodules.		
							95					

AEP MT LBR LF FKA SI/GPJ AEP.GDT 7/23/15

Continued Next Page

AMERICAN ELECTRIC POWER SERVICE CORPORATION
AEP CIVIL ENGINEERING LABORATORY
 LOG OF BORING



JOB NUMBER _____

COMPANY **APPALACHIAN POWER COMPANY**

BORING NO. **96-22** DATE **7/23/15** SHEET **5** OF **10**

PROJECT **MOUNTAINEER LBR LANDFILL**

BORING START **9/4/96** BORING FINISH **9/6/96**

SAMPLE NUMBER	SAMPLE	SAMPLE DEPTH IN FEET		STANDARD PENETRATION RESISTANCE BLOWS / 6"	TOTAL LENGTH RECOVERY	RQD	DEPTH IN FEET	GRAPHIC LOG	USCS	SOIL / ROCK IDENTIFICATION	WELL	DRILLER'S NOTES
		FROM	TO			%						
10	NQ	100.2	110.2		10.0	90	100			RED CLAYSHALE		
							105			GRAY SANDY SHALE		
11	NQ	110.2	120.2		10.0	98	110			DARK GREENISH GRAY 5G 4:1 SANDY CLAYSHALE Hard, well cemented, fine grain some cross bedding.		
							115			DARK REDDISH BROWN 10R 3/4 CLAYSHALE Soft.		
							120			MEDIUM GRAY N-5 SANDSTONE Hard, well cemented, silty, fine grain.		
12	NQ	120.2	130.2		9.0	90				GRAY SANDY SHALE Well cemented.		

AEP MT LBR LF FKA SI/GPJ AEP.GDT 7/23/15

Continued Next Page

AMERICAN ELECTRIC POWER SERVICE CORPORATION
AEP CIVIL ENGINEERING LABORATORY
 LOG OF BORING



JOB NUMBER _____

COMPANY **APPALACHIAN POWER COMPANY**

BORING NO. **96-22** DATE **7/23/15** SHEET **6** OF **10**

PROJECT **MOUNTAINEER LBR LANDFILL**

BORING START **9/4/96** BORING FINISH **9/6/96**

SAMPLE NUMBER	SAMPLE	SAMPLE DEPTH IN FEET		STANDARD PENETRATION RESISTANCE BLOWS / 6"	TOTAL LENGTH RECOVERY	RQD	DEPTH IN FEET	GRAPHIC LOG	USCS	SOIL / ROCK IDENTIFICATION	WELL	DRILLER'S NOTES
		FROM	TO			%						
							125			RED AND GRAY MOTTLED CLAYSHALE		
13	NQ	130.2	140.2		10.0	47	130		RED CLAYSHALE High angle fracture at 135.0,140.2.			
							135					
14	NQ	140.2	150.2		10.0	93	140		LIGHT GRAY CLAYSHALE Interbedded with sandstone.			
							145					

AEP MT LBR LF FKA SI/GPJ AEP.GDT 7/23/15

Continued Next Page

AMERICAN ELECTRIC POWER SERVICE CORPORATION
AEP CIVIL ENGINEERING LABORATORY
 LOG OF BORING



JOB NUMBER _____

COMPANY **APPALACHIAN POWER COMPANY**

BORING NO. **96-22** DATE **7/23/15** SHEET **7** OF **10**

PROJECT **MOUNTAINEER LBR LANDFILL**

BORING START **9/4/96** BORING FINISH **9/6/96**

SAMPLE NUMBER	SAMPLE	SAMPLE DEPTH IN FEET		STANDARD PENETRATION RESISTANCE BLOWS / 6"	TOTAL LENGTH RECOVERY	RQD	DEPTH IN FEET	GRAPHIC LOG	USCS	SOIL / ROCK IDENTIFICATION	WELL	DRILLER'S NOTES
		FROM	TO			%						
15	NQ	150.2	160.2		10.0	59						
							155			RED CLAYSHALE		153.0 Top of seal.
16	NQ	160.2	170.2		10.0	60	160					160.0 Top of sand.
							165			GRAY CLAYSHALE Limestone nodules.		163.0 Top of screen.
17	NQ	170.2	180.2		10.0	100	170			Interbedded sandstone		
							175					

AEP MT LBR LF FKA SI/GPJ AEP.GDT 7/23/15

Continued Next Page

AMERICAN ELECTRIC POWER SERVICE CORPORATION
AEP CIVIL ENGINEERING LABORATORY
 LOG OF BORING



JOB NUMBER _____

COMPANY **APPALACHIAN POWER COMPANY**

BORING NO. **96-22** DATE **7/23/15** SHEET **8** OF **10**

PROJECT **MOUNTAINEER LBR LANDFILL**

BORING START **9/4/96** BORING FINISH **9/6/96**

SAMPLE NUMBER	SAMPLE	SAMPLE DEPTH IN FEET		STANDARD PENETRATION RESISTANCE BLOWS / 6"	TOTAL LENGTH RECOVERY	RQD	DEPTH IN FEET	GRAPHIC LOG	USCS	SOIL / ROCK IDENTIFICATION	WELL	DRILLER'S NOTES
		FROM	TO			%						
18	NQ	180.2	190.2		10.0	100	180					
										GRAY SANDSTONE Massive.		
							185			GRAY CLAYSHALE Interbedded sandstone.		
19	NQ	190.2	200.2		10.0	89	190			MEDIUM GRAY N-5 SANDSTONE With shale cross bedding.		
										GRAYISH RED 10R 4½ CLAYSHALE		192.0 Bottom of screen.
							195					194.0 Bottom of sand.
20	NQ	200.2	210.2		10.0	87	200					

AEP MT LBR LF FKA SJ/GPJ AEP.GDT 7/23/15

Continued Next Page

AMERICAN ELECTRIC POWER SERVICE CORPORATION
AEP CIVIL ENGINEERING LABORATORY
 LOG OF BORING



JOB NUMBER _____

COMPANY **APPALACHIAN POWER COMPANY**

BORING NO. **96-22** DATE **7/23/15** SHEET **9** OF **10**

PROJECT **MOUNTAINEER LBR LANDFILL**

BORING START **9/4/96** BORING FINISH **9/6/96**

SAMPLE NUMBER	SAMPLE	SAMPLE DEPTH IN FEET		STANDARD PENETRATION RESISTANCE BLOWS / 6"	TOTAL LENGTH RECOVERY	RQD	DEPTH IN FEET	GRAPHIC LOG	USCS	SOIL / ROCK IDENTIFICATION	WELL	DRILLER'S NOTES
		FROM	TO			%						
							205			LIGHT GRAY N-7 SANDSTONE Shale cross bedding. Fine grain, massive.		
21	NQ	210.2	220.2		10.0	90	210		Shale cross bedding. LIGHT GRAY SANDSTONE Hard, massive.			
										MEDIUM GRAY N-5 CLAYSHALE		
							215		LIGHT GRAY SANDSTONE Massive, hard.			
										MEDIUM GRAY CLAYSHALE		
22	NQ	220.2	230.2		10.0	69	220		GRAYISH RED 10R 4\2 CLAYSHALE High angle fracture.			
							225					

AEP MT LBR LF FKA SI/GPJ AEP.GDT 7/23/15

Continued Next Page

AMERICAN ELECTRIC POWER SERVICE CORPORATION
AEP CIVIL ENGINEERING LABORATORY
 LOG OF BORING



JOB NUMBER _____

COMPANY **APPALACHIAN POWER COMPANY**

BORING NO. **96-22** DATE **7/23/15** SHEET **10** OF **10**

PROJECT **MOUNTAINEER LBR LANDFILL**

BORING START **9/4/96** BORING FINISH **9/6/96**

SAMPLE NUMBER	SAMPLE	SAMPLE DEPTH IN FEET		STANDARD PENETRATION RESISTANCE BLOWS / 6"	TOTAL LENGTH RECOVERY	RQD	DEPTH IN FEET	GRAPHIC LOG	USCS	SOIL / ROCK IDENTIFICATION	WELL	DRILLER'S NOTES
		FROM	TO			%						
							230			SWL 1-7-97 109.55. 8L 10 MIN. SWL 136 Ph 8.39 COND. 2610. 9L 14.5 MIN. SWL 151. 49L 30 MIN. SWL 167 pH 8.62 COND 2560 LIGHT RED. 76L 45 MIN. SWL 174. 92L 60 MIN. SWL 178.2 pH 8.51 COND 2570 REDDISH LIGHT RED. 108L 75 MIN. SWL 182.4. 135L 90 MIN. SWL 188.5 pH 8.48 COND 2520. 105 MIN. SWL 193.0. 1-8-97 22 HRS. SWL 191.48. pH 8.20 COND 2590. pH 8.43 COND. 2680. 2L DRY. 1-9-97 10:40 AM SWL 191.55. 2-6-97 SWL 183.03.		

AMERICAN ELECTRIC POWER SERVICE CORPORATION
AEP CIVIL ENGINEERING LABORATORY
 LOG OF BORING



JOB NUMBER _____
 COMPANY **APPALACHIAN POWER COMPANY**
 PROJECT **MOUNTAINEER LBR LANDFILL**
 COORDINATES **N 708,450.6 E 1,698,953.5**
 GROUND ELEVATION **690.5** SYSTEM _____

BORING NO. **96-23** DATE **7/23/15** SHEET **1** OF **7**
 BORING START **10/9/96** BORING FINISH **10/15/96**
 PIEZOMETER TYPE _____ WELL TYPE **OW**
 HGT. RISER ABOVE GROUND **2.05** DIA **2.0**
 DEPTH TO TOP OF WELL SCREEN **91.9** BOTTOM **111.0**
 WELL DEVELOPMENT **YES** BACKFILL **QUICK GROUT**
 FIELD PARTY **REB-LD** RIG **JOY 22**

Water Level, ft	<input type="checkbox"/>	<input type="checkbox"/>	<input type="checkbox"/>
TIME			
DATE			

SAMPLE NUMBER	SAMPLE	SAMPLE DEPTH IN FEET		STANDARD PENETRATION RESISTANCE BLOWS / 6"	TOTAL LENGTH RECOVERY	RQD %	DEPTH IN FEET	GRAPHIC LOG	USCS	SOIL / ROCK IDENTIFICATION	WELL	DRILLER'S NOTES
		FROM	TO									
												SWL in NQ hole 7.6' Boring produced a lot of water while advancing air hammer. No drill water used to advance boring. Decon 1-13-96 potable water and Alconox.
1	NQ	8.9	21.2		10.0	55	5					
							10			MEDIUM LIGHT GRAY N-6 SANDSTONE Fine to medium grain.		
							15			MEDIUM LIGHT GRAY N-6 CLAYSHALE GRAYISH RED 10R 4/2 CLAYSHALE		

TYPE OF CASING USED

X	NQ-2 ROCK CORE
	6" x 3.25 HSA
	9" x 6.25 HSA
	HW CASING ADVANCER 4"
	NW CASING 3"
	SW CASING 6"
	AIR HAMMER 8"

Continued Next Page

PIEZOMETER TYPE: PT = OPEN TUBE POROUS TIP, SS = OPEN TUBE SLOTTED SCREEN, G = GEONOR, P = PNEUMATIC

WELL TYPE: OW = OPEN TUBE SLOTTED SCREEN, GM = GEOMON

RECORDER **LD**

AMERICAN ELECTRIC POWER SERVICE CORPORATION
AEP CIVIL ENGINEERING LABORATORY
 LOG OF BORING



JOB NUMBER _____

COMPANY **APPALACHIAN POWER COMPANY**

BORING NO. **96-23** DATE **7/23/15** SHEET **2** OF **7**

PROJECT **MOUNTAINEER LBR LANDFILL**

BORING START **10/9/96** BORING FINISH **10/15/96**

SAMPLE NUMBER	SAMPLE	SAMPLE DEPTH IN FEET		STANDARD PENETRATION RESISTANCE BLOWS / 6"	TOTAL LENGTH RECOVERY	RQD	DEPTH IN FEET	GRAPHIC LOG	USCS	SOIL / ROCK IDENTIFICATION	WELL	DRILLER'S NOTES
		FROM	TO			%						
2	NQ	21.2	31.2		7.2	43				DARK REDDISH BROWN 10R 3/4 SILTY CLAYSHALE		
							25			MEDIUM LIGHT GRAY N-6 SANDSTONE Fine grain.		
										MEDIUM GRAY N-5 SANDSTONE Medium grain.		
3	NQ	31.2	41.2		9.8	60	30			MEDIUM LIGHT GRAY N-6 SANDSTONE Fine to medium grain.		
							35					
										MEDIUM LIGHT GRAY N-6 CLAYSHALE		
4	NQ	41.2	51.2		8.1	19	40			GRAYISH RED 10R 4/2 CLAYSHALE DARK REDDISH BROWN 10R 4/2 CLAYSHALE		
							45					

AEP MT LBR LF FKA SI/GPJ AEP.GDT 7/23/15

Continued Next Page

AMERICAN ELECTRIC POWER SERVICE CORPORATION
AEP CIVIL ENGINEERING LABORATORY
 LOG OF BORING



JOB NUMBER _____

COMPANY **APPALACHIAN POWER COMPANY**

BORING NO. **96-23** DATE **7/23/15** SHEET **3** OF **7**

PROJECT **MOUNTAINEER LBR LANDFILL**

BORING START **10/9/96** BORING FINISH **10/15/96**

SAMPLE NUMBER	SAMPLE	SAMPLE DEPTH IN FEET		STANDARD PENETRATION RESISTANCE BLOWS / 6"	TOTAL LENGTH RECOVERY	RQD	DEPTH IN FEET	GRAPHIC LOG	USCS	SOIL / ROCK IDENTIFICATION	WELL	DRILLER'S NOTES
		FROM	TO			%						
5	NQ	51.2	61.2		9.4	60	50			MEDIUM LIGHT GRAY N-6 CLAYSHALE		
							55			MEDIUM GRAY N-5 SANDY SHALE Fine grain.		
6	NQ	61.2	71.2		10.0	72	60			Well cemented		
							65					
7	NQ	71.2	81.2		9.6	76	70			MEDIUM LIGHT GRAY N-6 SANDSTONE Fine to medium grain.		

AEP MT LBR LF FKA SIGPJ AEP.GDT 7/23/15

Continued Next Page

AMERICAN ELECTRIC POWER SERVICE CORPORATION
AEP CIVIL ENGINEERING LABORATORY
 LOG OF BORING



JOB NUMBER _____

COMPANY **APPALACHIAN POWER COMPANY**

BORING NO. **96-23** DATE **7/23/15** SHEET **4** OF **7**

PROJECT **MOUNTAINEER LBR LANDFILL**

BORING START **10/9/96** BORING FINISH **10/15/96**

SAMPLE NUMBER	SAMPLE	SAMPLE DEPTH IN FEET		STANDARD PENETRATION RESISTANCE BLOWS / 6"	TOTAL LENGTH RECOVERY	RQD	DEPTH IN FEET	GRAPHIC LOG	USCS	SOIL / ROCK IDENTIFICATION	WELL	DRILLER'S NOTES
		FROM	TO			%						
							75					
8	NQ	81.2	91.2		9.0	88	80			GRAYISH RED 10R 4½ CLAYSHALE		
							85			MULTI COLORED DARK REDDISH BROWN, GRAY, GRAY BLACK 10R 3¼ CLAYSHALE		82.2 Top of seal.
							90					87.9 Top of sand.
9	NQ	91.2	101.2		10.0		95			MEDIUM N-5 SANDY SHALE Fine grain.		91.9 Top screen.

AEP MT LBR LF FKA SI/GPJ AEP.GDT 7/23/15

Continued Next Page

AMERICAN ELECTRIC POWER SERVICE CORPORATION
AEP CIVIL ENGINEERING LABORATORY
 LOG OF BORING



JOB NUMBER _____

COMPANY **APPALACHIAN POWER COMPANY**

BORING NO. **96-23** DATE **7/23/15** SHEET **5** OF **7**

PROJECT **MOUNTAINEER LBR LANDFILL**

BORING START **10/9/96** BORING FINISH **10/15/96**

SAMPLE NUMBER	SAMPLE	SAMPLE DEPTH IN FEET		STANDARD PENETRATION RESISTANCE BLOWS / 6"	TOTAL LENGTH RECOVERY	RQD	DEPTH IN FEET	GRAPHIC LOG	USCS	SOIL / ROCK IDENTIFICATION	WELL	DRILLER'S NOTES
		FROM	TO			%						
10	NQ	101.2	111.2		10.0	85	100					
11	NQ	111.2	121.2		96	43	110			GRAYISH RED 10R 4 1/2 CLAYSHALE GRAYISH RED 10R 4 1/2 MULTI COLORED GRAY MOTTLED BROWN, RED CLAYSHALE		111.0 Bottom of screen. 112.1 Bottom of sand.
12	NQ	121.2	131.2		10.0	38	120					

AEP MT LBR LF FKA SI/GPJ AEP.GDT 7/23/15

Continued Next Page

AMERICAN ELECTRIC POWER SERVICE CORPORATION
AEP CIVIL ENGINEERING LABORATORY
 LOG OF BORING



JOB NUMBER _____

COMPANY **APPALACHIAN POWER COMPANY**

BORING NO. **96-23** DATE **7/23/15** SHEET **6** OF **7**

PROJECT **MOUNTAINEER LBR LANDFILL**

BORING START **10/9/96** BORING FINISH **10/15/96**

SAMPLE NUMBER	SAMPLE	SAMPLE DEPTH IN FEET		STANDARD PENETRATION RESISTANCE BLOWS / 6"	TOTAL LENGTH RECOVERY	RQD	DEPTH IN FEET	GRAPHIC LOG	USCS	SOIL / ROCK IDENTIFICATION	WELL	DRILLER'S NOTES
		FROM	TO			%						
							125					
13	NQ	131.2	141.2		10.0		130			GRAYISH RED 10R 4½ CLAYSHALE MEDIUM LIGHT GRAY N-6 SANDY SHALE		
							135					
							140			MEDIUM GRAY N½ SANDY SHALE		
14	NQ	141.2	151.2		10.0		145					
												149.0 Bottom of bottom seal.

AEP MT LBR LF FKA SI/GPJ AEP.GDT 7/23/15

Continued Next Page

AMERICAN ELECTRIC POWER SERVICE CORPORATION
AEP CIVIL ENGINEERING LABORATORY
 LOG OF BORING



JOB NUMBER _____

COMPANY **APPALACHIAN POWER COMPANY**

BORING NO. **96-23** DATE **7/23/15** SHEET **7** OF **7**

PROJECT **MOUNTAINEER LBR LANDFILL**

BORING START **10/9/96** BORING FINISH **10/15/96**

SAMPLE NUMBER	SAMPLE	SAMPLE DEPTH IN FEET		STANDARD PENETRATION RESISTANCE BLOWS / 6"	TOTAL LENGTH RECOVERY	RQD	DEPTH IN FEET	GRAPHIC LOG	USCS	SOIL / ROCK IDENTIFICATION	WELL	DRILLER'S NOTES
		FROM	TO			%						
										1-31-97 SWL 36.7'. pH COND. TEMP. GALLONS SWL. 10.07 1007 52 2.0 49.4. 10.00 976 53 2.0 64.1. 10.13 980 56 2.0 77.9. 10.07 962 56 2.0 92.6. 9.90 865 56 2.0 95.8. 9.80 1004 56 4.0 98.0. 10.20 994 56 4.0 103.0. 10.12 990 56 6.0 108.6. 10.07 995 56 5 DRY. 9:30 SWL 113.0 10:00 112.7. 12:00 112.0. 2-6-97 SWL 111.70.		

AMERICAN ELECTRIC POWER SERVICE CORPORATION
AEP CIVIL ENGINEERING LABORATORY
 LOG OF BORING



JOB NUMBER _____
 COMPANY **APPALACHIAN POWER COMPANY**
 PROJECT **MOUNTAINEER LBR LANDFILL**
 COORDINATES **N 709,245.0 E 1,732,142.0**
 GROUND ELEVATION **825.5** SYSTEM _____

BORING NO. **96-24** DATE **7/23/15** SHEET **1** OF **10**
 BORING START **9/17/96** BORING FINISH **9/23/96**
 PIEZOMETER TYPE _____ WELL TYPE **OW**
 HGT. RISER ABOVE GROUND **N/A** DIA _____
 DEPTH TO TOP OF WELL SCREEN **N/A** BOTTOM **N/A**
 WELL DEVELOPMENT **N/A** BACKFILL **QUICK GROUT**
 FIELD PARTY **REB-RLY** RIG **JOY 22**

Water Level, ft	<input type="checkbox"/>	<input type="checkbox"/>	<input type="checkbox"/>
TIME			
DATE			

SAMPLE NUMBER	SAMPLE	SAMPLE DEPTH IN FEET		STANDARD PENETRATION RESISTANCE BLOWS / 6"	TOTAL LENGTH RECOVERY	RQD %	DEPTH IN FEET	GRAPHIC LOG	USCS	SOIL / ROCK IDENTIFICATION	WELL	DRILLER'S NOTES
		FROM	TO									
1	SS	0.0	1.5		.7				CL	BROWN SANDY CLAY		
2	SS	1.5	3.0		1.1							
3	SS	3.0	4.5		.9					BROWN SILTY CLAY SHALE		
4	SS	4.5	6.0		1.1		5			RED CLAY SHALE		
5	SS	6.0	7.5		.9							
6	SS	7.5	9.0		.8							
7	SS	9.0	10.5		1.1		10					
8	NQ	11.0	20.0		5.1	22				MODERATE REDDISH BROWN 10R 4/6 CLAYSHALE		
							15			GRAYISH ORANGE 10YR 7/4 CLAYSHALE		

TYPE OF CASING USED

X	NQ-2 ROCK CORE
	6" x 3.25 HSA
	9" x 6.25 HSA
	HW CASING ADVANCER 4"
	NW CASING 3"
	SW CASING 6"
	AIR HAMMER 8"

Continued Next Page

PIEZOMETER TYPE: PT = OPEN TUBE POROUS TIP, SS = OPEN TUBE SLOTTED SCREEN, G = GEONOR, P = PNEUMATIC
 WELL TYPE: OW = OPEN TUBE SLOTTED SCREEN, GM = GEOMON

RECORDER **RLY**

AMERICAN ELECTRIC POWER SERVICE CORPORATION
AEP CIVIL ENGINEERING LABORATORY
 LOG OF BORING



JOB NUMBER _____

COMPANY **APPALACHIAN POWER COMPANY**

BORING NO. **96-24** DATE **7/23/15** SHEET **2** OF **10**

PROJECT **MOUNTAINEER LBR LANDFILL**

BORING START **9/17/96** BORING FINISH **9/23/96**

SAMPLE NUMBER	SAMPLE	SAMPLE DEPTH IN FEET		STANDARD PENETRATION RESISTANCE BLOWS / 6"	TOTAL LENGTH RECOVERY	RQD	DEPTH IN FEET	GRAPHIC LOG	USCS	SOIL / ROCK IDENTIFICATION	WELL	DRILLER'S NOTES
		FROM	TO			%						
9	NQ	20.0	30.0		4.4	0				5Y 5/2 LIGHT OLIVE GRAY CLAYSHALE Soft.		
							25			10R 5/4 PALE REDDISH BROWN CLAYSHALE Soft.		
10	NQ	30.0	40.0		8.0	50	30					
							35			5B 5/1 MEDIUM BLUISH GRAY SANDY SHALE		
11	NQ	40.0	50.0		10.0	100	40					
							45			.5 VERTICAL CRACK 44.5'		

AEP MT LBR LF FKA SI/GPJ AEP.GDT 7/23/15

Continued Next Page

AMERICAN ELECTRIC POWER SERVICE CORPORATION
AEP CIVIL ENGINEERING LABORATORY
 LOG OF BORING



JOB NUMBER _____

COMPANY **APPALACHIAN POWER COMPANY**

BORING NO. **96-24** DATE **7/23/15** SHEET **3** OF **10**

PROJECT **MOUNTAINEER LBR LANDFILL**

BORING START **9/17/96** BORING FINISH **9/23/96**

SAMPLE NUMBER	SAMPLE	SAMPLE DEPTH IN FEET		STANDARD PENETRATION RESISTANCE BLOWS / 6"	TOTAL LENGTH RECOVERY	RQD	DEPTH IN FEET	GRAPHIC LOG	USCS	SOIL / ROCK IDENTIFICATION	WELL	DRILLER'S NOTES
		FROM	TO			%						
12	NQ	50.0	60.0		10.0	80	50			5YR 4/1 BROWNISH GRAY CLAYSHALE		
										5B 5/1 MEDIUM BLUISH GRAY SANDSTONE With shale partings.		
							55			5YR 4/1 BROWNISH GRAY CLAYSHALE		
13	NQ	60.0	70.0		10.0	30	60			10R 4/6 MODERATE REDDISH BROWN CLAYSHALE With high angle fractures at 66.4'		
							65			5B 5/1 MEDIUM BLUISH GRAY SHALE SANDSTONE Hard.		
14	NQ	70.0	80.0		10.0	100	70			MEDIUM GRAY SANDY SHALE Limestone nodules.		

AEP_Mt.LBR.LF.FKA.SI.GPJ_AEP.GDT_7/23/15

Continued Next Page

AMERICAN ELECTRIC POWER SERVICE CORPORATION
AEP CIVIL ENGINEERING LABORATORY
 LOG OF BORING



JOB NUMBER _____

COMPANY **APPALACHIAN POWER COMPANY**

BORING NO. **96-24** DATE **7/23/15** SHEET **4** OF **10**

PROJECT **MOUNTAINEER LBR LANDFILL**

BORING START **9/17/96** BORING FINISH **9/23/96**

SAMPLE NUMBER	SAMPLE	SAMPLE DEPTH IN FEET		STANDARD PENETRATION RESISTANCE BLOWS / 6"	TOTAL LENGTH RECOVERY	RQD	DEPTH IN FEET	GRAPHIC LOG	USCS	SOIL / ROCK IDENTIFICATION	WELL	DRILLER'S NOTES
		FROM	TO			%						
							75			5B 7:1 MEDIUM GRAY SANDY SHALE Hard.		
							80					
							85					
							90					
15	NQ	90.0	100.0		10.0	100	90			N-7 LIGHT GRAY SANDSTONE		5B 7:1 LIGHT BLuish GRAY SANDSTONE With shale partings, well cemented.
							95					

AEP MT LBR LF FKA SI/GPJ AEP.GDT 7/23/15

Continued Next Page

AMERICAN ELECTRIC POWER SERVICE CORPORATION
AEP CIVIL ENGINEERING LABORATORY
 LOG OF BORING



JOB NUMBER _____

COMPANY **APPALACHIAN POWER COMPANY**

BORING NO. **96-24** DATE **7/23/15** SHEET **5** OF **10**

PROJECT **MOUNTAINEER LBR LANDFILL**

BORING START **9/17/96** BORING FINISH **9/23/96**

SAMPLE NUMBER	SAMPLE	SAMPLE DEPTH IN FEET		STANDARD PENETRATION RESISTANCE BLOWS / 6"	TOTAL LENGTH RECOVERY	RQD	DEPTH IN FEET	GRAPHIC LOG	U S C S	SOIL / ROCK IDENTIFICATION	WELL	DRILLER'S NOTES
		FROM	TO			%						
16	NQ	100.0	110.0		10.0	56	100			N4 MEDIUM DARK GRAY SHALEY SANDSTONE Limestone nodules.		
							105			N5 GRAY SANDSTONE 5B 5\1 MEDIUM BLUISH GRAY SANDSTONE		
17	NQ	110.0	120.0		10.0	100	110			5B 5\1 MEDIUM BLUISH GRAY CLAYSHALE 10R 5\4 PALE REDDISH BROWN CLAYSHALE		
18	NQ	120.0	130.0		10.0	67	120					

AEP MT LBR LF FKA SI/GPJ AEP.GDT 7/23/15

Continued Next Page

AMERICAN ELECTRIC POWER SERVICE CORPORATION
AEP CIVIL ENGINEERING LABORATORY
 LOG OF BORING



JOB NUMBER _____

COMPANY **APPALACHIAN POWER COMPANY**

BORING NO. **96-24** DATE **7/23/15** SHEET **6** OF **10**

PROJECT **MOUNTAINEER LBR LANDFILL**

BORING START **9/17/96** BORING FINISH **9/23/96**

SAMPLE NUMBER	SAMPLE	SAMPLE DEPTH IN FEET		STANDARD PENETRATION RESISTANCE BLOWS / 6"	TOTAL LENGTH RECOVERY	RQD	DEPTH IN FEET	GRAPHIC LOG	USCS	SOIL / ROCK IDENTIFICATION	WELL	DRILLER'S NOTES
		FROM	TO			%						
							125			5B 5\1 MEDIUM BLUISH GRAY CLAYSHALE Limestone nodules.		
19	NQ	130.0	140.0		10.0	40	130			N7 LIGHT GRAY SANDSTONE		
										10 5\4 PALE REDDISH BROWN CLAYSHALE		
							135			5B 5\1 MEDIUM BLUISH GRAY SANDY SHALE		
20	NQ	140.0	150.0		10.0	86	140			5b 5\1 MEDIUM BLUISH GRAY CLAYSHALE Limestone nodules.		
										5B 7\1 LIGHT BLUISH GRAY SANDSTONE		
							145			RED CLAYSHALE		

AEP MT LBR LF FKA SI/GPJ AEP.GDT 7/23/15

Continued Next Page

AMERICAN ELECTRIC POWER SERVICE CORPORATION
AEP CIVIL ENGINEERING LABORATORY
 LOG OF BORING



JOB NUMBER _____

COMPANY **APPALACHIAN POWER COMPANY**

BORING NO. **96-24** DATE **7/23/15** SHEET **7** OF **10**

PROJECT **MOUNTAINEER LBR LANDFILL**

BORING START **9/17/96** BORING FINISH **9/23/96**

SAMPLE NUMBER	SAMPLE	SAMPLE DEPTH IN FEET		STANDARD PENETRATION RESISTANCE BLOWS / 6"	TOTAL LENGTH RECOVERY	RQD	DEPTH IN FEET	GRAPHIC LOG	U S C S	SOIL / ROCK IDENTIFICATION	WELL	DRILLER'S NOTES
		FROM	TO			%						
21	NQ	150.0	160.0		9.5	87	155			5B 5/1 MEDIUM BLUISH GRAY SHALEY SANDSTONE		
										N-6 MEDIUM LIGHT GRAY SANDY SHALE		
22	NQ	160.0	170.0		9.4	52	160			N-4 MEDIUM DARK GRAY WITH RED LAYERS CLAYSHALE		
										RED, GRAY, BROWN MOTTLED CLAYSHALE		
23	NQ	170.0	180.0		10.0	92	165			5R 3/4 DUSKY RED CLAYSHALE		
										RED, GRAY, BROWN MOTTLED CLAYSHALE		
							170			N5 MEDIUM GRAY SANDY SHALE Fine to medium grain.		
							175					

AEP MT LBR LF FKA SI/GPJ AEP.GDT 7/23/15

Continued Next Page

AMERICAN ELECTRIC POWER SERVICE CORPORATION
AEP CIVIL ENGINEERING LABORATORY
 LOG OF BORING



JOB NUMBER _____

COMPANY **APPALACHIAN POWER COMPANY**

BORING NO. **96-24** DATE **7/23/15** SHEET **8** OF **10**

PROJECT **MOUNTAINEER LBR LANDFILL**

BORING START **9/17/96** BORING FINISH **9/23/96**

SAMPLE NUMBER	SAMPLE	SAMPLE DEPTH IN FEET		STANDARD PENETRATION RESISTANCE BLOWS / 6"	TOTAL LENGTH RECOVERY	RQD	DEPTH IN FEET	GRAPHIC LOG	U S C S	SOIL / ROCK IDENTIFICATION	WELL	DRILLER'S NOTES
		FROM	TO			%						
24	NQ	180.0	190.0		9.4	32	180			N-6 MEDIUM LIGHT GRAY SANDY SHALE Fine grain.		
							185			RED, GRAY, BROWN MOTTLED CLAYSHALE 10R 2 1/2 VERY DUSKY RED CLAYSHALE		
25	NQ	190.0	200.0		9.4	67	190			10R 3/4 DARK REDDISH, BROWN, RED CLAYSHALE		
							195			N-5 MEDIUM GRAY SANDY SHALE		
							200			5R 4 1/2 GRAYISH RED CLAYSHALE Limestone nodules. N4 MEDIUM DARK GRAY SANDY SHALE		
26	NQ	200.0	210.0		10.0	100	200			N-6 MEDIUM DARK GRAY SANDY SHALE		

AEP MT LBR LF FKA SI/GPJ AEP.GDT 7/23/15

Continued Next Page

AMERICAN ELECTRIC POWER SERVICE CORPORATION
AEP CIVIL ENGINEERING LABORATORY
 LOG OF BORING



JOB NUMBER _____

COMPANY **APPALACHIAN POWER COMPANY**

BORING NO. **96-24** DATE **7/23/15** SHEET **9** OF **10**

PROJECT **MOUNTAINEER LBR LANDFILL**

BORING START **9/17/96** BORING FINISH **9/23/96**

SAMPLE NUMBER	SAMPLE	SAMPLE DEPTH IN FEET		STANDARD PENETRATION RESISTANCE BLOWS / 6"	TOTAL LENGTH RECOVERY	RQD	DEPTH IN FEET	GRAPHIC LOG	USCS	SOIL / ROCK IDENTIFICATION	WELL	DRILLER'S NOTES
		FROM	TO			%						
							205					
27	NQ	210.0	220.0		9.4	71	210			N-5 MEDIUM GRAY SANDSTONE With shale partings. Cross bedding		
							215					
28	NQ	220.0	230.0		9.6	54	220			N-4 MEDIUM DARK GRAY SANDY SHALE Fine grain N-5 MEDIUM GRAY SANDY SHALE Fine grain. RED, GRAY, BROWN MOTTLED CLAYSHALE		
							225			N-4 MEDIUM DARK GRAY, RED STREAKS CLAYSHALE		

AEP MT LBR LF FKA SI/GPJ AEP.GDT 7/23/15

Continued Next Page

AMERICAN ELECTRIC POWER SERVICE CORPORATION
AEP CIVIL ENGINEERING LABORATORY
 LOG OF BORING



JOB NUMBER _____

COMPANY **APPALACHIAN POWER COMPANY**

BORING NO. **96-24** DATE **7/23/15** SHEET **10** OF **10**

PROJECT **MOUNTAINEER LBR LANDFILL**

BORING START **9/17/96** BORING FINISH **9/23/96**

SAMPLE NUMBER	SAMPLE	SAMPLE DEPTH IN FEET		STANDARD PENETRATION RESISTANCE BLOWS / 6"	TOTAL LENGTH RECOVERY	RQD	DEPTH IN FEET	GRAPHIC LOG	USCS	SOIL / ROCK IDENTIFICATION	WELL	DRILLER'S NOTES
		FROM	TO			%						
							230			5R 3/4 DUSKY RED CLAYSHALE		
							235					
							240					

AMERICAN ELECTRIC POWER SERVICE CORPORATION
AEP CIVIL ENGINEERING LABORATORY
 LOG OF BORING



JOB NUMBER _____
 COMPANY **APPALACHIAN POWER COMPANY**
 PROJECT **MOUNTAINEER LBR LANDFILL**
 COORDINATES **N 712,597.9 E 1,699,973.8**
 GROUND ELEVATION **718.1** SYSTEM _____

BORING NO. **96-27** DATE **7/23/15** SHEET **1** OF **8**
 BORING START **9/25/96** BORING FINISH **10/9/96**
 PIEZOMETER TYPE _____ WELL TYPE **OW**
 HGT. RISER ABOVE GROUND **1.43** DIA **2.0**
 DEPTH TO TOP OF WELL SCREEN **111.0** BOTTOM **130.0**
 WELL DEVELOPMENT _____ BACKFILL **QUICK GROUT**
 FIELD PARTY **REB-TLS-RLY** RIG **JOY 22**

Water Level, ft	<input type="checkbox"/>	<input type="checkbox"/>	<input type="checkbox"/>
TIME			
DATE			

SAMPLE NUMBER	SAMPLE	SAMPLE DEPTH IN FEET		STANDARD PENETRATION RESISTANCE BLOWS / 6"	TOTAL LENGTH RECOVERY	RQD %	DEPTH IN FEET	GRAPHIC LOG	USCS	SOIL / ROCK IDENTIFICATION	WELL	DRILLER'S NOTES
		FROM	TO									
							5					Decon 1-15-97 potable water and Alconox. SWL 1-16-97 NQ hole 70.65 SWL 66.35 8" hole to 100' 500 gallons of water use to flush hole. SWL after installation 99.8. From 181.2 to 132 tremie backfill w/ bentonite pellets
1	NQ	15.7	20.6		4.9	37	15			PALE REDDISH BROWN 10R 5/4 SANDY SHALE Brown sandstone nodules.		

TYPE OF CASING USED				<i>Continued Next Page</i>								
X	NQ-2 ROCK CORE			PIEZOMETER TYPE: PT = OPEN TUBE POROUS TIP, SS = OPEN TUBE SLOTTED SCREEN, G = GEONOR, P = PNEUMATIC								
	6" x 3.25 HSA			WELL TYPE: OW = OPEN TUBE SLOTTED SCREEN, GM = GEOMON								
	9" x 6.25 HSA			RECORDER TLS-RLY								
	HW CASING ADVANCER 4"											
	NW CASING 3"											
	SW CASING 6"											
	AIR HAMMER 8"											

AEP_Mt_LBR_LF_FKA_SiG_PU_AEP_GDT_7/23/15

AMERICAN ELECTRIC POWER SERVICE CORPORATION
AEP CIVIL ENGINEERING LABORATORY
 LOG OF BORING



JOB NUMBER _____

COMPANY **APPALACHIAN POWER COMPANY**

BORING NO. **96-27** DATE **7/23/15** SHEET **2** OF **8**

PROJECT **MOUNTAINEER LBR LANDFILL**

BORING START **9/25/96** BORING FINISH **10/9/96**

SAMPLE NUMBER	SAMPLE	SAMPLE DEPTH IN FEET		STANDARD PENETRATION RESISTANCE BLOWS / 6"	TOTAL LENGTH RECOVERY	RQD	DEPTH IN FEET	GRAPHIC LOG	USCS	SOIL / ROCK IDENTIFICATION	WELL	DRILLER'S NOTES
		FROM	TO			%						
2	NQ	20.6	30.6		10.0							
							25			PALE YELLOWISH BROWN 10YR 6/2 SANDSTONE Fine to medium grain.		
										MEDIUM GRAY N-5 SILTY CLAYSHALE		
										PALE YELLOWISH BROWN 10YR 6/2 SANDY SHALE		
										MEDIUM LIGHT GRAY N/6 SANDSTONE		
										MEDIUM GRAY N-5 CLAYSHALE		
3	NQ	30.6	40.6		3.6	18	30			MEDIUM LIGHT GRAY N-6 SILTY CLAYSHALE		
							35					
							40			DUSKY RED 5R 3/4 SILTY CLAYSHALE		
4	NQ	40.6	44.6		1.1	0						
5	NQ	44.6	50.6		6.0	100	45			MEDIUM GRAY N-5 SANDSTONE Fine to medium grain.		

AEP MT LBR LF FKA SI/GPJ AEP.GDT 7/23/15

Continued Next Page

AMERICAN ELECTRIC POWER SERVICE CORPORATION
AEP CIVIL ENGINEERING LABORATORY
 LOG OF BORING



JOB NUMBER _____

COMPANY **APPALACHIAN POWER COMPANY**

BORING NO. **96-27** DATE **7/23/15** SHEET **3** OF **8**

PROJECT **MOUNTAINEER LBR LANDFILL**

BORING START **9/25/96** BORING FINISH **10/9/96**

SAMPLE NUMBER	SAMPLE	SAMPLE DEPTH IN FEET		STANDARD PENETRATION RESISTANCE BLOWS / 6"	TOTAL LENGTH RECOVERY	RQD	DEPTH IN FEET	GRAPHIC LOG	U S C S	SOIL / ROCK IDENTIFICATION	WELL	DRILLER'S NOTES
		FROM	TO			%						
6	NQ	50.6	55.6		4.4	33	50					
7	NQ	55.6	61.2		5.6	41	55			MEDIUM GRAY 5-N CLAYSHALE MEDIUM GRAY N-5 CLAYSHALE DUSKY RED 5R CLAYSHALE		
8	NQ	61.2	71.2		9.5	64	60					
							65			MEDIUM GRAY N-5 CLAYSHALE		
9	NQ	71.2	81.2		9.5	68	70					

AEP MT LBR LF FKA SI/GPJ AEP.GDT 7/23/15

Continued Next Page

AMERICAN ELECTRIC POWER SERVICE CORPORATION
AEP CIVIL ENGINEERING LABORATORY
 LOG OF BORING



JOB NUMBER _____

COMPANY **APPALACHIAN POWER COMPANY**

BORING NO. **96-27** DATE **7/23/15** SHEET **4** OF **8**

PROJECT **MOUNTAINEER LBR LANDFILL**

BORING START **9/25/96** BORING FINISH **10/9/96**

SAMPLE NUMBER	SAMPLE	SAMPLE DEPTH IN FEET		STANDARD PENETRATION RESISTANCE BLOWS / 6"	TOTAL LENGTH RECOVERY	RQD	DEPTH IN FEET	GRAPHIC LOG	USCS	SOIL / ROCK IDENTIFICATION	WELL	DRILLER'S NOTES
		FROM	TO			%						
							75					
10	NQ	81.2	91.2		9.5	57				DARK GRAY N-3 SILTY CLAYSHALE With vertical crack.		
							85			MEDIUM GRAY N-5 SANDSTONE With cross bedding.		
11	NQ	91.2	101.2		6.2	29				Medium to fine grain.		
							95			DARK GRAY N-3 CLAYSHALE Trace of red.		

AEP MT LBR LF FKA SI/GPJ AEP.GDT 7/23/15

Continued Next Page

AMERICAN ELECTRIC POWER SERVICE CORPORATION
AEP CIVIL ENGINEERING LABORATORY
 LOG OF BORING



JOB NUMBER _____

COMPANY **APPALACHIAN POWER COMPANY**

BORING NO. **96-27** DATE **7/23/15** SHEET **5** OF **8**

PROJECT **MOUNTAINEER LBR LANDFILL**

BORING START **9/25/96** BORING FINISH **10/9/96**

SAMPLE NUMBER	SAMPLE	SAMPLE DEPTH IN FEET		STANDARD PENETRATION RESISTANCE BLOWS / 6"	TOTAL LENGTH RECOVERY	RQD	DEPTH IN FEET	GRAPHIC LOG	USCS	SOIL / ROCK IDENTIFICATION	WELL	DRILLER'S NOTES
		FROM	TO			%						
12	NQ	101.2	111.2		9.1	16	100			MEDIUM DARK GRAY N-4 CLAYSHALE		102.6 Top of seal.
							105			DARK REDDISH BROWN 10R 3/4 RED, BROWN, GRAY MOTTLED CLAYSHALE		109.0 Top of sand.
13	NQ	111.2	121.2		9.9	75	110			MEDIUM GRAY N-5 SANDY SHALE		111.0 Top of screen.
							115			MEDIUM GRAY N-5 SANDSTONE Medium to fine grain, vertical fracture 119.2-120.0.		
14	NQ	121.2	131.2		9.1	49	120			MEDIUM GRAY N-5 CLAYSHALE MEDIUM DARK GRAY N-4 CLAYSHALE		

AEP MT LBR LF FKA SI/GPJ AEP.GDT 7/23/15

Continued Next Page

AMERICAN ELECTRIC POWER SERVICE CORPORATION
AEP CIVIL ENGINEERING LABORATORY
 LOG OF BORING



JOB NUMBER _____

COMPANY **APPALACHIAN POWER COMPANY**

BORING NO. **96-27** DATE **7/23/15** SHEET **6** OF **8**

PROJECT **MOUNTAINEER LBR LANDFILL**

BORING START **9/25/96** BORING FINISH **10/9/96**

SAMPLE NUMBER	SAMPLE	SAMPLE DEPTH IN FEET		STANDARD PENETRATION RESISTANCE BLOWS / 6"	TOTAL LENGTH RECOVERY	RQD	DEPTH IN FEET	GRAPHIC LOG	USCS	SOIL / ROCK IDENTIFICATION	WELL	DRILLER'S NOTES
		FROM	TO			%						
							125			MEDIUM GRAY N-5 SANDY SHALE		
										GRAYISH RED 5R 4/2 MOTTLED RED, BROWN, GRAY CLAYSHALE		
15	NQ	131.2	141.2		9.2	42	130			DARK REDDISH BROWN 10R 3/4 MOTTLED REDDISH BROWN GRAY CLAYSHALE		130.0 Bottom of screen. 132.0 Bottom of sand.
							135					
16	NQ	141.2	151.2		8.9	53	140					
							145			MEDIUM LIGHT GRAY N-6 SANDSTONE		
										DARK REDDISH BROWN 10R 3/4 MOTTLED CLAYSHALE		
										MEDIUM DARK GRAY N-4 SANDY SHALE		

AEP MT LBR LF FKA SI/GPJ AEP.GDT 7/23/15

Continued Next Page

AMERICAN ELECTRIC POWER SERVICE CORPORATION
AEP CIVIL ENGINEERING LABORATORY
 LOG OF BORING



JOB NUMBER _____

COMPANY **APPALACHIAN POWER COMPANY**

BORING NO. **96-27** DATE **7/23/15** SHEET **7** OF **8**

PROJECT **MOUNTAINEER LBR LANDFILL**

BORING START **9/25/96** BORING FINISH **10/9/96**

SAMPLE NUMBER	SAMPLE	SAMPLE DEPTH IN FEET		STANDARD PENETRATION RESISTANCE BLOWS / 6"	TOTAL LENGTH RECOVERY	RQD	DEPTH IN FEET	GRAPHIC LOG	USCS	SOIL / ROCK IDENTIFICATION	WELL	DRILLER'S NOTES
		FROM	TO			%						
17	NQ	151.2	161.2		10.0	97						
							155			MEDIUM LIGHT GRAY N-6 SANDSTONE Fine to medium grain.		
18	NQ	161.2	171.2		10.0	100						
							165					
19	NQ	171.2	181.2		8.3	59						
							175			DARK REDDISH BROWN 10R 3/4 MOTTLED RED, BROWN, GRAY CLAYSHALE		

AEP MT LBR LF FKA SI/GPJ AEP.GDT 7/23/15

Continued Next Page

AMERICAN ELECTRIC POWER SERVICE CORPORATION
AEP CIVIL ENGINEERING LABORATORY
 LOG OF BORING



JOB NUMBER _____

COMPANY **APPALACHIAN POWER COMPANY**

BORING NO. **96-27** DATE **7/23/15** SHEET **8** OF **8**

PROJECT **MOUNTAINEER LBR LANDFILL**

BORING START **9/25/96** BORING FINISH **10/9/96**

SAMPLE NUMBER	SAMPLE	SAMPLE DEPTH IN FEET		STANDARD PENETRATION RESISTANCE BLOWS / 6"	TOTAL LENGTH RECOVERY	RQD	DEPTH IN FEET	GRAPHIC LOG	USCS	SOIL / ROCK IDENTIFICATION	WELL	DRILLER'S NOTES
		FROM	TO			%						
							180					
										pH COND TEMP. GALLONS SWL . 9.80 695 55 2.0 83.5. 9.81 699 56 2.0 84.8. 9.91 690 56 2.0 87.2. 9.94 685 57 2.0 88.8 9.88 682 58 2.0 90.6. 9.73 681 58 2.0 92.8. 9.75 680 58 2.0 95.5. 9.85 684 58 4.0 101.2. 9.82 694 58 4.0 106.7. 9.84 687 58 4.0 110.9. 9.86 698 58 4.0 114.6. 9.88 698 58 4.0 115.7. 9.85 702 58 4.0 117.1. 9.73 701 58 6.0 119.3. 9.73 701 58 6.0 122.3. 9.72 713 58 6.0 124.6. 9.85 704 58 +6.0 127.4. 9.83 719 58 6.0 131.6. 3:58 SWL DRY. 4:05 126.7. 4:15 123.3. 4:30 120.9 1-23-97 swl 8:38 AM 10.04 713 55 2.0 86.9. 9.91 703 56 4.0 92.3. 9.92 718 56 4.0 95.9. 9.86 705 56 4.0 101.4. 9.23 752 56 4.0 105.3. 9.07 56 6.0 111.5. 9.87 56 8.0 118.9. 9.78 56 8.0 122.0. 9.85 56 8.0 124.4. 9.88 56 8.0 129.1. 9.91 3.0 132.0. DRY. 2-6-97 SWL 73.99.		

AMERICAN ELECTRIC POWER SERVICE CORPORATION
AEP CIVIL ENGINEERING LABORATORY
 LOG OF BORING



JOB NUMBER _____
 COMPANY **APPALACHIAN POWER COMPANY**
 PROJECT **MOUNTAINEER LBR LANDFILL**
 COORDINATES **N 708,701.0 E 1,697,043.0**
 GROUND ELEVATION **879.6** SYSTEM _____

BORING NO. **96-28** DATE **7/23/15** SHEET **1** OF **10**
 BORING START _____ BORING FINISH **12/10/96**
 PIEZOMETER TYPE _____ WELL TYPE **OW**
 HGT. RISER ABOVE GROUND **1.7** DIA **2.0**
 DEPTH TO TOP OF WELL SCREEN **69.8** BOTTOM **98.9**
 WELL DEVELOPMENT **YES** BACKFILL **QUICK GROUT**
 FIELD PARTY **TJH-RLY** RIG **CME-75**

Water Level, ft	<input type="checkbox"/>	<input type="checkbox"/>	<input type="checkbox"/>
TIME			
DATE			

SAMPLE NUMBER	SAMPLE	SAMPLE DEPTH IN FEET		STANDARD PENETRATION RESISTANCE BLOWS / 6"	TOTAL LENGTH RECOVERY	RQD %	DEPTH IN FEET	GRAPHIC LOG	USCS	SOIL / ROCK IDENTIFICATION	WELL	DRILLER'S NOTES
		FROM	TO									
							5		CL	LIGHT BROWN SILTY CLAY REDDISH BROWN CLAY		Some water showing in cuttings. SWL 9:30 12-11-96 possible excess drill water. Boring flushed with 300 to 500 prior to well installation.
							10			TAN TO BROWN CLAYSHALE		
							15			MODERATE REDDISH BROWN 10R 4/6 CLAYSHALE		
										GREENISH GRAY SILTY CLAYSHALE Medium hard.		
										MEDIUM GRAY N-5 SILTY CLAYSHALE Sandstone lens, 21.5, 24.8 vertical fractures.		

TYPE OF CASING USED

NQ-2 ROCK CORE	
6" x 3.25 HSA	
9" x 6.25 HSA	
HW CASING ADVANCER	4"
NW CASING	3"
SW CASING	6"
AIR HAMMER	8"

Continued Next Page

PIEZOMETER TYPE: PT = OPEN TUBE POROUS TIP, SS = OPEN TUBE SLOTTED SCREEN, G = GEONOR, P = PNEUMATIC
 WELL TYPE: OW = OPEN TUBE SLOTTED SCREEN, GM = GEOMON

RECORDER _____

AMERICAN ELECTRIC POWER SERVICE CORPORATION
AEP CIVIL ENGINEERING LABORATORY
 LOG OF BORING



JOB NUMBER _____

COMPANY **APPALACHIAN POWER COMPANY**

BORING NO. **96-28** DATE **7/23/15** SHEET **2** OF **10**

PROJECT **MOUNTAINEER LBR LANDFILL**

BORING START _____ BORING FINISH **12/10/96**

SAMPLE NUMBER	SAMPLE	SAMPLE DEPTH IN FEET		STANDARD PENETRATION RESISTANCE BLOWS / 6"	TOTAL LENGTH RECOVERY	RQD	DEPTH IN FEET	GRAPHIC LOG	USCS	SOIL / ROCK IDENTIFICATION	WELL	DRILLER'S NOTES
		FROM	TO			%						
							25			MEDIUM LIGHT GRAY N-6 SANDY CLAYSHALE Hard.		
							30					
							35					
							40			PALE OLIVE 10Y 6/2 SANDSTONE Hard, medium to large grain.		
							45					

AEP MT LBR LF FKA SI/GPJ AEP.GDT 7/23/15

Continued Next Page

AMERICAN ELECTRIC POWER SERVICE CORPORATION
AEP CIVIL ENGINEERING LABORATORY
 LOG OF BORING



JOB NUMBER _____

COMPANY **APPALACHIAN POWER COMPANY**

BORING NO. **96-28** DATE **7/23/15** SHEET **3** OF **10**

PROJECT **MOUNTAINEER LBR LANDFILL**

BORING START _____ BORING FINISH **12/10/96**

SAMPLE NUMBER	SAMPLE	SAMPLE DEPTH IN FEET		STANDARD PENETRATION RESISTANCE BLOWS / 6"	TOTAL LENGTH RECOVERY	RQD %	DEPTH IN FEET	GRAPHIC LOG	USCS	SOIL / ROCK IDENTIFICATION	WELL	DRILLER'S NOTES
		FROM	TO									
							50			MEDIUM LIGHT GRAY N-6 SANDSTONE Hard, medium to large grain.		
							55					
							57.9 TO 58.5			MEDIUM GRAY N-5 CLAYSHALE vertical fracture.		
							60			GRAYISH RED 10R 4½ CLAYSHALE		58.9 Top of seal.
							65			GRAYISH RED 10R 4½ CLAYSHALE		65.0 Top of sand.
							70			MEDIUM GRAY N-5 CLAYSHALE		69.8 Top of screen.

AEP MT LBR LF FKA SI/GPJ AEP.GDT 7/23/15

Continued Next Page

AMERICAN ELECTRIC POWER SERVICE CORPORATION
AEP CIVIL ENGINEERING LABORATORY
 LOG OF BORING



JOB NUMBER _____

COMPANY **APPALACHIAN POWER COMPANY**

BORING NO. **96-28** DATE **7/23/15** SHEET **4** OF **10**

PROJECT **MOUNTAINEER LBR LANDFILL**

BORING START _____ BORING FINISH **12/10/96**

SAMPLE NUMBER	SAMPLE	SAMPLE DEPTH IN FEET		STANDARD PENETRATION RESISTANCE BLOWS / 6"	TOTAL LENGTH RECOVERY	RQD	DEPTH IN FEET	GRAPHIC LOG	USCS	SOIL / ROCK IDENTIFICATION	WELL	DRILLER'S NOTES
		FROM	TO			%						
							75					
							80					
							85			MEDIUM GRAY N-5 SILTY SANDSTONE Medium to large grain.		
							90			MEDIUM GRAY N-5 CLAYSHALE		
							95			MEDIUM DARK GRAY N-4 SILTY CLAYSHLE Hard.		

AEP MT LBR LF FKA SI/GPJ AEP.GDT 7/23/15

Continued Next Page

AMERICAN ELECTRIC POWER SERVICE CORPORATION
AEP CIVIL ENGINEERING LABORATORY
 LOG OF BORING



JOB NUMBER _____

COMPANY **APPALACHIAN POWER COMPANY**

BORING NO. **96-28** DATE **7/23/15** SHEET **5** OF **10**

PROJECT **MOUNTAINEER LBR LANDFILL**

BORING START _____ BORING FINISH **12/10/96**

SAMPLE NUMBER	SAMPLE	SAMPLE DEPTH IN FEET		STANDARD PENETRATION RESISTANCE BLOWS / 6"	TOTAL LENGTH RECOVERY	RQD	DEPTH IN FEET	GRAPHIC LOG	USCS	SOIL / ROCK IDENTIFICATION	WELL	DRILLER'S NOTES
		FROM	TO			%						
							100			GRAYISH RED 5R 4/2 SANDY CLAYSHALE Medium hard.		98.9 Bottom of screen. 100.0 Bottom of sand.
							105			DARK REDDISH BROWN 10R 3/4 CLAY SHALE Well cemented.		
							110			MEDIUM GRAY N-5 CLAYSHALE		
							115			DARK REDDISH BROWN 10R 3/4 SILTY CLAYSHALE MEDIUM DARK GRAY N-4 CLAYSHALE Well cemented.		
							120					

AEP MT LBR LF FKA SI/GPJ AEP.GDT 7/23/15

Continued Next Page

AMERICAN ELECTRIC POWER SERVICE CORPORATION
AEP CIVIL ENGINEERING LABORATORY
 LOG OF BORING



JOB NUMBER _____

COMPANY **APPALACHIAN POWER COMPANY**

BORING NO. **96-28** DATE **7/23/15** SHEET **6** OF **10**

PROJECT **MOUNTAINEER LBR LANDFILL**

BORING START _____ BORING FINISH **12/10/96**

SAMPLE NUMBER	SAMPLE	SAMPLE DEPTH IN FEET		STANDARD PENETRATION RESISTANCE BLOWS / 6"	TOTAL LENGTH RECOVERY	RQD	DEPTH IN FEET	GRAPHIC LOG	USCS	SOIL / ROCK IDENTIFICATION	WELL	DRILLER'S NOTES
		FROM	TO			%						
							125			MEDIUM DARK GRAY N-4 SANDSTONE Fine to medium grain, cross bedding.		
							130					
							135					
							140			DARK GREENISH GRAY 5G 4/12 CLAYSHALE Well cemented, broken are 140, 142.		
							145			MEDIUM DARK GRAY N-4 SANDSTONE Fine to medium grain.		

AEP MT LBR LF FKA SI/GPJ AEP.GDT 7/23/15

Continued Next Page

AMERICAN ELECTRIC POWER SERVICE CORPORATION
AEP CIVIL ENGINEERING LABORATORY
 LOG OF BORING



JOB NUMBER _____

COMPANY **APPALACHIAN POWER COMPANY**

BORING NO. **96-28** DATE **7/23/15** SHEET **7** OF **10**

PROJECT **MOUNTAINEER LBR LANDFILL**

BORING START _____ BORING FINISH **12/10/96**

SAMPLE NUMBER	SAMPLE	SAMPLE DEPTH IN FEET		STANDARD PENETRATION RESISTANCE BLOWS / 6"	TOTAL LENGTH RECOVERY	RQD	DEPTH IN FEET	GRAPHIC LOG	USCS	SOIL / ROCK IDENTIFICATION	WELL	DRILLER'S NOTES
		FROM	TO			%						
										MEDIUM GRAY N-5 SANDSTONE Fine to medium grain, well cemented.		
							155			MEDIUM DARK GRAY N-4 SANDSTONE Fine to medium grain.		
							160			MEDIUM GRAY N-5 CLAYSHALE GRAYISH RED 10R 4½ CLAYSHALE		
							165			MEDIUM DARK GRAY N-4 SANDSTONE Fine to medium grain.		
							170			GRAYISH RED 10R 4½ CLAYSHEL		
							175					

AEP MT LBR LF FKA SI/GPJ AEP.GDT 7/23/15

Continued Next Page

AMERICAN ELECTRIC POWER SERVICE CORPORATION
AEP CIVIL ENGINEERING LABORATORY
 LOG OF BORING



JOB NUMBER _____

COMPANY **APPALACHIAN POWER COMPANY**

BORING NO. **96-28** DATE **7/23/15** SHEET **8** OF **10**

PROJECT **MOUNTAINEER LBR LANDFILL**

BORING START _____ BORING FINISH **12/10/96**

SAMPLE NUMBER	SAMPLE	SAMPLE DEPTH IN FEET		STANDARD PENETRATION RESISTANCE BLOWS / 6"	TOTAL LENGTH RECOVERY	RQD	DEPTH IN FEET	GRAPHIC LOG	U S C S	SOIL / ROCK IDENTIFICATION	WELL	DRILLER'S NOTES
		FROM	TO			%						
							180			MEDIUM DARK GRAY N-4 CLAYEY SANDSTONE		
							185			GRAYISH RED 1-R 4/2 CLAYSHALE		
							190			MEDIUM GRAY N-5 CLAYSHALE		
							195			DARK GRAY N-3 CLAYSHALE		
							200			LIGHT OLIVE GRAY 5Y 5/2 SANDY CLAYSHALE		

AEP MT LBR LF FKA SJGPJ AEP.GDT 7/23/15

Continued Next Page

AMERICAN ELECTRIC POWER SERVICE CORPORATION
AEP CIVIL ENGINEERING LABORATORY
 LOG OF BORING



JOB NUMBER _____

COMPANY **APPALACHIAN POWER COMPANY**

BORING NO. **96-28** DATE **7/23/15** SHEET **9** OF **10**

PROJECT **MOUNTAINEER LBR LANDFILL**

BORING START _____ BORING FINISH **12/10/96**

SAMPLE NUMBER	SAMPLE	SAMPLE DEPTH IN FEET		STANDARD PENETRATION RESISTANCE BLOWS / 6"	TOTAL LENGTH RECOVERY	RQD	DEPTH IN FEET	GRAPHIC LOG	USCS	SOIL / ROCK IDENTIFICATION	WELL	DRILLER'S NOTES
		FROM	TO			%						
							205			GRAYISH PURPLE SANDY CLAYSHLAE		
							210			GRAYISH PURPLE 5P 4I2 CLAYSHALE Broken, medium hard.		
							215			LIGHT GRAY N-7 SANDSTONE Hard, well cemented, cross bedding, medium to large grain.		
							220			MEDIUM LIGHT GRAY N-6 TO DARK REDDISH 10R 2I2 SILTY CLAYSHALE Medium hard.		
							225			1-8-97 SWL 98.0. L pH COM.SWL. 1 8.70 770 98.0. 2 8.60 859. 3 8.82 884. 4 8.93 906 99.2.		

AEP MT LBR LF FKA SI/GPJ AEP.GDT 7/23/15

Continued Next Page

AMERICAN ELECTRIC POWER SERVICE CORPORATION
AEP CIVIL ENGINEERING LABORATORY
 LOG OF BORING



JOB NUMBER _____

COMPANY **APPALACHIAN POWER COMPANY**

BORING NO. **96-28** DATE **7/23/15** SHEET **10** OF **10**

PROJECT **MOUNTAINEER LBR LANDFILL**

BORING START _____ BORING FINISH **12/10/96**

SAMPLE NUMBER	SAMPLE	SAMPLE DEPTH IN FEET		STANDARD PENETRATION RESISTANCE BLOWS / 6"	TOTAL LENGTH RECOVERY	RQD	DEPTH IN FEET	GRAPHIC LOG	USCS	SOIL / ROCK IDENTIFICATION	WELL	DRILLER'S NOTES
		FROM	TO			%						
										5 9.12 953. 6 9.13 912. 7 9.18 898. 8 9.17 877 100. 9 8.99 8.72. 10 9.13 8.59 . 11 8.91 8.58 100.8. 12 9.11 8.73 101.5. VERY REDDISH BROWN. 2-6-97 DRY BAILER IN WELL.		

AMERICAN ELECTRIC POWER SERVICE CORPORATION
AEP CIVIL ENGINEERING LABORATORY
 LOG OF BORING



JOB NUMBER _____

COMPANY **APPALACHIAN POWER COMPANY**

BORING NO. **96-29** DATE **7/23/15** SHEET **2** OF **9**

PROJECT **MOUNTAINEER LBR LANDFILL**

BORING START _____ BORING FINISH **12/4/96**

SAMPLE NUMBER	SAMPLE	SAMPLE DEPTH IN FEET		STANDARD PENETRATION RESISTANCE BLOWS / 6"	TOTAL LENGTH RECOVERY	RQD	DEPTH IN FEET	GRAPHIC LOG	USCS	SOIL / ROCK IDENTIFICATION	WELL	DRILLER'S NOTES
		FROM	TO			%						
							25			MEDIUM LIGHT GRAY N-6 SANDY CLAYSHALE Hard.		
							30					
							35					
							40			PALE OLIVE 10Y 6/2 SANDSTONE Hard, medium to large grain.		
							45					

AEP_Mt.LBR.LF.FKA.SI.GPJ_AEP.GDT_7/23/15

Continued Next Page

AMERICAN ELECTRIC POWER SERVICE CORPORATION
AEP CIVIL ENGINEERING LABORATORY
 LOG OF BORING



JOB NUMBER _____

COMPANY **APPALACHIAN POWER COMPANY**

BORING NO. **96-29** DATE **7/23/15** SHEET **3** OF **9**

PROJECT **MOUNTAINEER LBR LANDFILL**

BORING START _____ BORING FINISH **12/4/96**

SAMPLE NUMBER	SAMPLE	SAMPLE DEPTH IN FEET		STANDARD PENETRATION RESISTANCE BLOWS / 6"	TOTAL LENGTH RECOVERY	RQD	DEPTH IN FEET	GRAPHIC LOG	USCS	SOIL / ROCK IDENTIFICATION	WELL	DRILLER'S NOTES
		FROM	TO			%						
							50			MEDIUM LIGHT GRAY N-6 SANDSTONE Hard, medium to large grain.		
							55					
							60			MEDIUM GRAY N-5 CLAYSHALE 57.9 TO 58.5 vertical fracture. GRAYISH RED 10R 4 1/2 CLAYSHALE		
							65			GRAYISH RED 10R 4 1/2 CLAYSHALE		
							70			MEDIUM GRAY N-5 CLAYSHALE		

AEP MT LBR LF FKA SI/GPJ AEP.GDT 7/23/15

Continued Next Page

AMERICAN ELECTRIC POWER SERVICE CORPORATION
AEP CIVIL ENGINEERING LABORATORY
 LOG OF BORING



JOB NUMBER _____

COMPANY **APPALACHIAN POWER COMPANY**

BORING NO. **96-29** DATE **7/23/15** SHEET **4** OF **9**

PROJECT **MOUNTAINEER LBR LANDFILL**

BORING START _____ BORING FINISH **12/4/96**

SAMPLE NUMBER	SAMPLE	SAMPLE DEPTH IN FEET		STANDARD PENETRATION RESISTANCE BLOWS / 6"	TOTAL LENGTH RECOVERY	RQD %	DEPTH IN FEET	GRAPHIC LOG	U S C S	SOIL / ROCK IDENTIFICATION	WELL	DRILLER'S NOTES
		FROM	TO									
							75					
							80					
							85			MEDIUM GRAY N-5 SILTY SANDSTONE Medium to large grain.		
							90			MEDIUM GRAY N-5 CLAYSHALE		
							95			MEDIUM DARK GRAY N-4 SILTY CLAYSHLE Hard.		

AEP MT LBR LF FKA SI/GPJ AEP.GDT 7/23/15

Continued Next Page

AMERICAN ELECTRIC POWER SERVICE CORPORATION
AEP CIVIL ENGINEERING LABORATORY
 LOG OF BORING



JOB NUMBER _____

COMPANY **APPALACHIAN POWER COMPANY**

BORING NO. **96-29** DATE **7/23/15** SHEET **5** OF **9**

PROJECT **MOUNTAINEER LBR LANDFILL**

BORING START _____ BORING FINISH **12/4/96**

SAMPLE NUMBER	SAMPLE	SAMPLE DEPTH IN FEET		STANDARD PENETRATION RESISTANCE BLOWS / 6"	TOTAL LENGTH RECOVERY	RQD	DEPTH IN FEET	GRAPHIC LOG	USCS	SOIL / ROCK IDENTIFICATION	WELL	DRILLER'S NOTES
		FROM	TO			%						
							100			GRAYISH RED 5R 4/2 SANDY CLAYSHALE Medium hard.		
							105			DARK REDDISH BROWN 10R 3/4 CLAY SHALE Well cemented.		
							110			MEDIUM GRAY N-5 CLAYSHALE		
							115			DARK REDDISH BROWN 10R 3/4 SILTY CLAYSHALE MEDIUM DARK GRAY N-4 CLAYSHALE Well cemented.		
							120					

AEP MT LBR LF FKA SI/GPJ AEP.GDT 7/23/15

Continued Next Page

AMERICAN ELECTRIC POWER SERVICE CORPORATION
AEP CIVIL ENGINEERING LABORATORY
 LOG OF BORING



JOB NUMBER _____

COMPANY **APPALACHIAN POWER COMPANY**

BORING NO. **96-29** DATE **7/23/15** SHEET **6** OF **9**

PROJECT **MOUNTAINEER LBR LANDFILL**

BORING START _____ BORING FINISH **12/4/96**

SAMPLE NUMBER	SAMPLE	SAMPLE DEPTH IN FEET		STANDARD PENETRATION RESISTANCE BLOWS / 6"	TOTAL LENGTH RECOVERY	RQD	DEPTH IN FEET	GRAPHIC LOG	USCS	SOIL / ROCK IDENTIFICATION	WELL	DRILLER'S NOTES
		FROM	TO			%						
							125			MEDIUM DARK GRAY N-4 SANDSTONE Fine to medium grain, cross bedding.		
							130					
							135					
							140			DARK GREENISH GRAY 5G 4\12 CLAYSHALE Well cemented, broken are 140, 142.		
							145			MEDIUM DARK GRAY N-4 SANDSTONE Fine to medium grain.		144.1 Top seal.

AEP MT LBR LF FKA SJ/GPJ AEP.GDT 7/23/15

Continued Next Page

AMERICAN ELECTRIC POWER SERVICE CORPORATION
AEP CIVIL ENGINEERING LABORATORY
 LOG OF BORING



JOB NUMBER _____

COMPANY **APPALACHIAN POWER COMPANY**

BORING NO. **96-29** DATE **7/23/15** SHEET **7** OF **9**

PROJECT **MOUNTAINEER LBR LANDFILL**

BORING START _____ BORING FINISH **12/4/96**

SAMPLE NUMBER	SAMPLE	SAMPLE DEPTH IN FEET		STANDARD PENETRATION RESISTANCE BLOWS / 6"	TOTAL LENGTH RECOVERY	RQD	DEPTH IN FEET	GRAPHIC LOG	U S C S	SOIL / ROCK IDENTIFICATION	WELL	DRILLER'S NOTES
		FROM	TO			%						
										MEDIUM GRAY N-5 SANDSTONE Fine to medium grain, well cemented.		150.0 Top of sand.
							155			MEDIUM DARK GRAY N-4 SANDSTONE Fine to medium grain.		152.8 Top of screen.
							160			MEDIUM GRAY N-5 CLAYSHALE GRAYISH RED 10R 4½ CLAYSHALE		
							165			MEDIUM GRAY N-5 CLAYSHALE MEDIUM DARK GRAY N-4 SANDSTONE Fine to medium grain.		
							170			GRAYISH RED 10R 4½ CLAYSHEL		171.9 Bottom of screen
							175					174.0 Bottom of sand.

AEP MT LBR LF FKA SI/GPJ AEP.GDT 7/23/15

Continued Next Page

AMERICAN ELECTRIC POWER SERVICE CORPORATION
AEP CIVIL ENGINEERING LABORATORY
 LOG OF BORING



JOB NUMBER _____

COMPANY **APPALACHIAN POWER COMPANY**

BORING NO. **96-29** DATE **7/23/15** SHEET **8** OF **9**

PROJECT **MOUNTAINEER LBR LANDFILL**

BORING START _____ BORING FINISH **12/4/96**

SAMPLE NUMBER	SAMPLE	SAMPLE DEPTH IN FEET		STANDARD PENETRATION RESISTANCE BLOWS / 6"	TOTAL LENGTH RECOVERY	RQD	DEPTH IN FEET	GRAPHIC LOG	U S C S	SOIL / ROCK IDENTIFICATION	WELL	DRILLER'S NOTES
		FROM	TO			%						
							180			MEDIUM DARK GRAY N-4 CLAYEY SANDSTONE		
							185			GRAYISH RED 1-R 4/2 CLAYSHALE		
							190			MEDIUM GRAY N-5 CLAYSHALE		
							195			DARK GRAY N-3 CLAYSHALE		
							200			LIGHT OLIVE GRAY 5Y 5/2 SANDY CLAYSHALE		

AEP MT LBR LF FKA SJGPJ AEP.GDT 7/23/15

Continued Next Page

AMERICAN ELECTRIC POWER SERVICE CORPORATION
AEP CIVIL ENGINEERING LABORATORY
 LOG OF BORING



JOB NUMBER _____

COMPANY **APPALACHIAN POWER COMPANY**

BORING NO. **96-29** DATE **7/23/15** SHEET **9** OF **9**

PROJECT **MOUNTAINEER LBR LANDFILL**

BORING START _____ BORING FINISH **12/4/96**

SAMPLE NUMBER	SAMPLE	SAMPLE DEPTH IN FEET		STANDARD PENETRATION RESISTANCE BLOWS / 6"	TOTAL LENGTH RECOVERY	RQD	DEPTH IN FEET	GRAPHIC LOG	U S C S	SOIL / ROCK IDENTIFICATION	WELL	DRILLER'S NOTES
		FROM	TO			%						
							205			GRAYISH PURPLE SANDY CLAYSHLAE		
							210			GRAYISH PURPLE 5P 4I2 CLAYSHALE Broken, medium hard.		
							215			LIGHT GRAY N-7 SANDSTONE Hard, well cemented, cross bedding, medium to large grain.		
							220					
							225			MEDIUM LIGHT GRAY N-6 TO DARK REDDISH 10R 2I2 SILTY CLAYSHALE Medium hard.		
							228					1-8-97 SWL DRY. 2-6-97 SWL DRY.

AMERICAN ELECTRIC POWER SERVICE CORPORATION
AEP CIVIL ENGINEERING LABORATORY
 LOG OF BORING



JOB NUMBER _____
 COMPANY **APPALACHIAN POWER COMPANY**
 PROJECT **MOUNTAINEER LBR LANDFILL**
 COORDINATES **N 708,701.0 E 1,697,043.0**
 GROUND ELEVATION **879.8** SYSTEM _____

BORING NO. **96-30** DATE **7/23/15** SHEET **1** OF **10**
 BORING START **9/5/96** BORING FINISH **9/11/96**
 PIEZOMETER TYPE _____ WELL TYPE **OW**
 HGT. RISER ABOVE GROUND **1.71** DIA **2.0**
 DEPTH TO TOP OF WELL SCREEN **195.9** BOTTOM **225.0**
 WELL DEVELOPMENT **YES** BACKFILL **QUICK GROUT**
 FIELD PARTY **MCR-LD** RIG **BK-81**

Water Level, ft	▽ DRY	▽ 35.1	▽ 45.2
TIME			14 hrs.
DATE	9-9-96	9-10-96	9-11-96

SAMPLE NUMBER	SAMPLE	SAMPLE DEPTH IN FEET		STANDARD PENETRATION RESISTANCE BLOWS / 6"	TOTAL LENGTH RECOVERY	RQD		DEPTH IN FEET	GRAPHIC LOG	USCS	SOIL / ROCK IDENTIFICATION	WELL	DRILLER'S NOTES
		FROM	TO			%							
1	SS	0.0	1.5	4-4-3	1.3					CL	LIGHT BROWN SILTY CLAY		4.7=9.2 NO SAMPLES TAKEN DRILL WATER BROWN TO RED CLAYSHALE. No water in well immediatly after installation 12-4-96
2	SS	1.5	3.0	3-3-4	1.0						REDDISH BROWN CLAY		
3	SS	3.0	4.5	9-18-37	1.0						TAN TO BROWN CLAYSHALE		
4	SS	4.5	4.7	50/2	0			5					
5	NQ	9.2	15.0		2.8	0		10			MODERATE REDDISH BROWN 10R 4/6 CLAYSHALE		Decon rig and tools with potalbe water and alconox. BORING FLUSHED WITH APPROXIMATELY 700 GALLONS OF WATER.
6	NQ	15.0	25.0		8.8	0		15			GREENISH GRAY SILTY CLAYSHALE Medium hard.		
											MEDIUM GRAY N-5 SILTY CLAYSHALE Sandstone lens, 21.5, 24.8 vertical fractures.		

TYPE OF CASING USED

X	NQ-2 ROCK CORE
	6" x 3.25 HSA
	9" x 6.25 HSA
	HW CASING ADVANCER 4"
	NW CASING 3"
	SW CASING 6"
	AIR HAMMER 8"

Continued Next Page

PIEZOMETER TYPE: PT = OPEN TUBE POROUS TIP, SS = OPEN TUBE SLOTTED SCREEN, G = GEONOR, P = PNEUMATIC
 WELL TYPE: OW = OPEN TUBE SLOTTED SCREEN, GM = GEOMON

RECORDER **LD**

AMERICAN ELECTRIC POWER SERVICE CORPORATION
AEP CIVIL ENGINEERING LABORATORY
 LOG OF BORING



JOB NUMBER _____

COMPANY **APPALACHIAN POWER COMPANY**

BORING NO. **96-30** DATE **7/23/15** SHEET **2** OF **10**

PROJECT **MOUNTAINEER LBR LANDFILL**

BORING START **9/5/96** BORING FINISH **9/11/96**

SAMPLE NUMBER	SAMPLE	SAMPLE DEPTH IN FEET		STANDARD PENETRATION RESISTANCE BLOWS / 6"	TOTAL LENGTH RECOVERY	RQD	DEPTH IN FEET	GRAPHIC LOG	USCS	SOIL / ROCK IDENTIFICATION	WELL	DRILLER'S NOTES
		FROM	TO			%						
7	NQ	25.0	35.0		10.0	39	25			MEDIUM LIGHT GRAY N-6 SANDY CLAYSHALE Hard.		
8	NQ	35.0	45.0		10.0	64	35			PALE OLIVE 10Y 6/2 SANDSTONE Hard, medium to large grain.		APPROXIMATELY 1000 GALLONS OF WATER USED.
9	NQ	45.0	55.0		10.0	96	45					

AEP MT LBR LF FKA SI/GPJ AEP.GDT 7/23/15

Continued Next Page

AMERICAN ELECTRIC POWER SERVICE CORPORATION
AEP CIVIL ENGINEERING LABORATORY
 LOG OF BORING



JOB NUMBER _____

COMPANY **APPALACHIAN POWER COMPANY**

BORING NO. **96-30** DATE **7/23/15** SHEET **3** OF **10**

PROJECT **MOUNTAINEER LBR LANDFILL**

BORING START **9/5/96** BORING FINISH **9/11/96**

SAMPLE NUMBER	SAMPLE	SAMPLE DEPTH IN FEET		STANDARD PENETRATION RESISTANCE BLOWS / 6"	TOTAL LENGTH RECOVERY	RQD	DEPTH IN FEET	GRAPHIC LOG	USCS	SOIL / ROCK IDENTIFICATION	WELL	DRILLER'S NOTES
		FROM	TO			%						
							50			MEDIUM LIGHT GRAY N-6 SANDSTONE Hard, medium to large grain.		
10	NQ	55.0	65.0		9.9	58	55			MEDIUM GRAY N-5 CLAYSHALE 57.9 TO 58.5 vertical fracture. GRAYISH RED 10R 4 1/2 CLAYSHALE		
							60					
11	NQ	65.0	66.5		1.3	53	65			GRAYISH RED 10R 4 1/2 CLAYSHALE		
12	NQ	66.5	75.0		7.4	73						
							70			MEDIUM GRAY N-5 CLAYSHALE		

AEP MT LBR LF FKA SI/GPJ AEP.GDT 7/23/15

Continued Next Page

AMERICAN ELECTRIC POWER SERVICE CORPORATION
AEP CIVIL ENGINEERING LABORATORY
 LOG OF BORING



JOB NUMBER _____

COMPANY **APPALACHIAN POWER COMPANY**

BORING NO. **96-30** DATE **7/23/15** SHEET **4** OF **10**

PROJECT **MOUNTAINEER LBR LANDFILL**

BORING START **9/5/96** BORING FINISH **9/11/96**

SAMPLE NUMBER	SAMPLE	SAMPLE DEPTH IN FEET		STANDARD PENETRATION RESISTANCE BLOWS / 6"	TOTAL LENGTH RECOVERY	RQD	DEPTH IN FEET	GRAPHIC LOG	USCS	SOIL / ROCK IDENTIFICATION	WELL	DRILLER'S NOTES
		FROM	TO			%						
13	NQ	75.0	85.0		9.9	95	75					
14	NQ	85.0	95.0		10.0	78	85		MEDIUM GRAY N-5 SILTY SANDSTONE Medium to large grain.			
15	NQ	95.0	105.0		10.0	20	95		MEDIUM GRAY N-5 CLAYSHALE MEDIUM DARK GRAY N-4 SILTY CLAYSHALE Hard.			

AEP_Mt.LBR.LF.FKA.SI.GPJ.AEP.GDT.7/23/15

Continued Next Page

AMERICAN ELECTRIC POWER SERVICE CORPORATION
AEP CIVIL ENGINEERING LABORATORY
 LOG OF BORING



JOB NUMBER _____

COMPANY **APPALACHIAN POWER COMPANY**

BORING NO. **96-30** DATE **7/23/15** SHEET **5** OF **10**

PROJECT **MOUNTAINEER LBR LANDFILL**

BORING START **9/5/96** BORING FINISH **9/11/96**

SAMPLE NUMBER	SAMPLE	SAMPLE DEPTH IN FEET		STANDARD PENETRATION RESISTANCE BLOWS / 6"	TOTAL LENGTH RECOVERY	RQD	DEPTH IN FEET	GRAPHIC LOG	USCS	SOIL / ROCK IDENTIFICATION	WELL	DRILLER'S NOTES
		FROM	TO			%						
							100			GRAYISH RED 5R 4/2 SANDY CLAYSHALE Medium hard.		
16	NQ	105.0	115.0		10.0	50	105			DARK REDDISH BROWN 10R 3/4 CLAY SHALE Well cemented.		
							110			MEDIUM GRAY N-5 CLAYSHALE		
17	NQ	115.0	125.0		7.2	72	115			DARK REDDISH BROWN 10R 3/4 SILTY CLAYSHALE MEDIUM DARK GRAY N-4 CLAYSHALE Well cemented.		
							120					

AEP MT LBR LF FKA SI/GPJ AEP.GDT 7/23/15

Continued Next Page

AMERICAN ELECTRIC POWER SERVICE CORPORATION
AEP CIVIL ENGINEERING LABORATORY
 LOG OF BORING



JOB NUMBER _____

COMPANY **APPALACHIAN POWER COMPANY**

BORING NO. **96-30** DATE **7/23/15** SHEET **6** OF **10**

PROJECT **MOUNTAINEER LBR LANDFILL**

BORING START **9/5/96** BORING FINISH **9/11/96**

SAMPLE NUMBER	SAMPLE	SAMPLE DEPTH IN FEET		STANDARD PENETRATION RESISTANCE BLOWS / 6"	TOTAL LENGTH RECOVERY	RQD	DEPTH IN FEET	GRAPHIC LOG	USCS	SOIL / ROCK IDENTIFICATION	WELL	DRILLER'S NOTES
		FROM	TO			%						
18	NQ	125.0	135.0		9.7	83	125			MEDIUM DARK GRAY N-4 SANDSTONE Fine to medium grain, cross bedding.		
							130					
19	NQ	135.0	145.0		9.4	87	135					
							140			DARK GREENISH GRAY 5G 4/12 CLAYSHALE Well cemented, broken are 140, 142.		
20	NQ	145.0	155.0		10.0	96	145			MEDIUM DARK GRAY N-4 SANDSTONE Fine to medium grain.		

AEP MT LBR LF FKA SI/GPJ AEP.GDT 7/23/15

Continued Next Page

AMERICAN ELECTRIC POWER SERVICE CORPORATION
AEP CIVIL ENGINEERING LABORATORY
 LOG OF BORING



JOB NUMBER _____

COMPANY **APPALACHIAN POWER COMPANY**

BORING NO. **96-30** DATE **7/23/15** SHEET **7** OF **10**

PROJECT **MOUNTAINEER LBR LANDFILL**

BORING START **9/5/96** BORING FINISH **9/11/96**

SAMPLE NUMBER	SAMPLE	SAMPLE DEPTH IN FEET		STANDARD PENETRATION RESISTANCE BLOWS / 6"	TOTAL LENGTH RECOVERY	RQD	DEPTH IN FEET	GRAPHIC LOG	USCS	SOIL / ROCK IDENTIFICATION	WELL	DRILLER'S NOTES
		FROM	TO			%						
										MEDIUM GRAY N-5 SANDSTONE Fine to medium grain, well cemented.		
21	NQ	155.0	165.0		10.0		155			MEDIUM DARK GRAY N-4 SANDSTONE Fine to medium grain.		
							160			MEDIUM GRAY N-5 CLAYSHALE GRAYISH RED 10R 4½ CLAYSHALE MEDIUM GRAY N-5 CLAYSHALE		
22	NQ	165.0	175.0		9.9	85	165			MEDIUM DARK GRAY N-4 SANDSTONE Fine to medium grain.		
							170			GRAYISH RED 10R 4½ CLAYSHALE		
23	NQ	175.0	185.0		10.0	71	175					

AEP MT LBR LF FKA SI/GPJ AEP.GDT 7/23/15

Continued Next Page

AMERICAN ELECTRIC POWER SERVICE CORPORATION
AEP CIVIL ENGINEERING LABORATORY
 LOG OF BORING



JOB NUMBER _____

COMPANY **APPALACHIAN POWER COMPANY**

BORING NO. **96-30** DATE **7/23/15** SHEET **8** OF **10**

PROJECT **MOUNTAINEER LBR LANDFILL**

BORING START **9/5/96** BORING FINISH **9/11/96**

SAMPLE NUMBER	SAMPLE	SAMPLE DEPTH IN FEET		STANDARD PENETRATION RESISTANCE BLOWS / 6"	TOTAL LENGTH RECOVERY	RQD	DEPTH IN FEET	GRAPHIC LOG	U S C S	SOIL / ROCK IDENTIFICATION	WELL	DRILLER'S NOTES
		FROM	TO			%						
							180			MEDIUM DARK GRAY N-4 CLAYEY SANDSTONE		
24	NQ	185.0	195.0		9.6	76	185			GRAYISH RED 1-R 4/2 CLAYSHALE		184.1 Top of seal. APPROXIMATELY 42000 GALLONS OF WATER USED.
							190			MEDIUM GRAY N-5 CLAYSHALE		190.0 Top of sand.
25	NQ	195.0	205.0		9.9	33	195			DARK GRAY N-3 CLAYSHALE		195.9 Top of screen.
							200			LIGHT OLIVE GRAY 5Y 5/2 SANDY CLAYSHALE		

AEP MT LBR LF FKA SI/GPJ AEP.GDT 7/23/15

Continued Next Page

AMERICAN ELECTRIC POWER SERVICE CORPORATION
AEP CIVIL ENGINEERING LABORATORY
 LOG OF BORING



JOB NUMBER _____

COMPANY **APPALACHIAN POWER COMPANY**

BORING NO. **96-30** DATE **7/23/15** SHEET **9** OF **10**

PROJECT **MOUNTAINEER LBR LANDFILL**

BORING START **9/5/96** BORING FINISH **9/11/96**

SAMPLE NUMBER	SAMPLE	SAMPLE DEPTH IN FEET		STANDARD PENETRATION RESISTANCE BLOWS / 6"	TOTAL LENGTH RECOVERY	RQD	DEPTH IN FEET	GRAPHIC LOG	USCS	SOIL / ROCK IDENTIFICATION	WELL	DRILLER'S NOTES
		FROM	TO			%						
26	NQ	205.0	215.0		9.9	88	205			GRAYISH PURPLE SANDY CLAYSHLAE		
										GRAYISH PURPLE 5P 4I2 CLAYSHALE Broken, medium hard.		
										LIGHT GRAY N-7 SANDSTONE Hard, well cemented, cross bedding, medium to large grain.		
							210					
27	NQ	215.0	225.0		9.9	82	215					
							220					
										MEDIUM LIGHT GRAY N-6 TO DARK REDDISH 10R 2 1/2 SILTY CLAYSHALE Medium hard.		
							225					
										1-8-97 SWL 202.4 L pH COND SWL 5 8.26 2160 204.7 WATER LIGHT BROWN. 10 8.39 2140 205.75. 15 8.59 2002 207.0 20 8.80 2000 207.95 SLIGHTLY DARKER.		225.0 Bottom of screen. 227.0 Bottom of sand.

AEP MT LBR LF FKA SI/GPJ AEP.GDT 7/23/15

Continued Next Page

AMERICAN ELECTRIC POWER SERVICE CORPORATION
AEP CIVIL ENGINEERING LABORATORY
 LOG OF BORING



JOB NUMBER _____

COMPANY **APPALACHIAN POWER COMPANY**

BORING NO. **96-30** DATE **7/23/15** SHEET **10** OF **10**

PROJECT **MOUNTAINEER LBR LANDFILL**

BORING START **9/5/96** BORING FINISH **9/11/96**

SAMPLE NUMBER	SAMPLE	SAMPLE DEPTH IN FEET		STANDARD PENETRATION RESISTANCE BLOWS / 6"	TOTAL LENGTH RECOVERY	RQD	DEPTH IN FEET	GRAPHIC LOG	USCS	SOIL / ROCK IDENTIFICATION	WELL	DRILLER'S NOTES
		FROM	TO			%						
										25 8.63 2008 209.15. 30 8.57 2007 210.55. 35 8.64 2009 212.1. 40 8.52 2120 213.65. 45 8.47 2140 215.2 DARK THAN ABOVE. 50 8.56 2120 216.55. 55 8.6 2140 218.3. 60 8.54 2140 219.45. 65 8.54 2190 221.4. 70 8.65 2200 222.4. 75 8.61 2230 224.0. 80 8.53 2120 225.1. 82 8.48 2170. 82L WELL DRY 4:40 PM. 1-9-97 10:50 AM SWL 221.85. pH COND. SWL 8.58 2220. 8.63 2230. 8.67 2180. 8.65 2160. 8.72 2190. 8.56 2150 224.8. 2-6-97 SWL 204.62.		

AMERICAN ELECTRIC POWER SERVICE CORPORATION
AEP CIVIL ENGINEERING LABORATORY
 LOG OF BORING



JOB NUMBER _____
 COMPANY **APPALACHIAN POWER COMPANY**
 PROJECT **MOUNTAINEER LBR LANDFILL**
 COORDINATES **N 711,108.2 E 1,696,404.8**
 GROUND ELEVATION **826.6** SYSTEM _____

BORING NO. **96-31** DATE **7/23/15** SHEET **1** OF **7**
 BORING START **9/11/96** BORING FINISH **9/12/96**
 PIEZOMETER TYPE _____ WELL TYPE **OW**
 HGT. RISER ABOVE GROUND **1.75** DIA **2.0**
 DEPTH TO TOP OF WELL SCREEN **55.8** BOTTOM **84.9**
 WELL DEVELOPMENT **YES** BACKFILL **QUICK GROUT**
 FIELD PARTY **MCR-LD** RIG **BK-81**

Water Level, ft	▽ 55.6	▼ 16.9	▽
TIME			
DATE	9-5-96	9-17-96	

SAMPLE NUMBER	SAMPLE	SAMPLE DEPTH IN FEET		STANDARD PENETRATION RESISTANCE BLOWS / 6"	TOTAL LENGTH RECOVERY	RQD %	DEPTH IN FEET	GRAPHIC LOG	USCS	SOIL / ROCK IDENTIFICATION	WELL	DRILLER'S NOTES
		FROM	TO									
1	SS	0.0	1.5	4-6-5	.8				CL	RED CLAY		Decon at fly ash site 9-11-96 8:30 using potable water. Hole grouted using 100 gallons quick grout. Decon rig and tools 12-11-96 with potable water and Alconox. Bentonite seal hydroate 12-11-96 grouting 12-12-96.
2	SS	1.5	3.0	8-8-12	.8							
4	SS	3.0	4.5	10-12-16	.8							
5	SS	4.5	6.0	15-19-19	1.0		5			BROWN SHALEY CLAY		
										GRAYISH BROWN CLAYSHALE		
6	SS	6.0	6.8	25-50/3	.6							
7	NQ	9.0	15.0		5.5	8	10			DARK YELLOWISH ORANGE 10YR 6/6 CLAYSHALE Soft.		
										Silty		
8	NQ	15.0	25.0		9.0	0	15			GRAYISH BLACK N-2 SILTY CLAYSHALE		

TYPE OF CASING USED	
X	NQ-2 ROCK CORE
	6" x 3.25 HSA
	9" x 6.25 HSA
	HW CASING ADVANCER 4"
	NW CASING 3"
	SW CASING 6"
	AIR HAMMER 8"

Continued Next Page

PIEZOMETER TYPE: PT = OPEN TUBE POROUS TIP, SS = OPEN TUBE SLOTTED SCREEN, G = GEONOR, P = PNEUMATIC

WELL TYPE: OW = OPEN TUBE SLOTTED SCREEN, GM = GEOMON

RECORDER **LD**

AEP MT LBR LF FKA SJG PU AEP.GDT 7/23/15

AMERICAN ELECTRIC POWER SERVICE CORPORATION
AEP CIVIL ENGINEERING LABORATORY
 LOG OF BORING



JOB NUMBER _____

COMPANY **APPALACHIAN POWER COMPANY**

BORING NO. **96-31** DATE **7/23/15** SHEET **2** OF **7**

PROJECT **MOUNTAINEER LBR LANDFILL**

BORING START **9/11/96** BORING FINISH **9/12/96**

SAMPLE NUMBER	SAMPLE	SAMPLE DEPTH IN FEET		STANDARD PENETRATION RESISTANCE BLOWS / 6"	TOTAL LENGTH RECOVERY	RQD	DEPTH IN FEET	GRAPHIC LOG	USCS	SOIL / ROCK IDENTIFICATION	WELL	DRILLER'S NOTES
		FROM	TO			%						
9	NQ	25.0	35.0		10.0	15	25			GRAYISH ORANGE 10R 74 CLAYSHALE		
										MODERATE YELLOWISH BROWN 10YR 5/4 SANDSTONE Medium grain.		
							30			MEDIUM DARK GRAY N-4 SANDSTONE Fine to medium grain.		
										LIGHT GRAY N-7 CLAYSHALE		
										MEDIUM LIGHT GRAY N-6 SANDSTONE		
										LIGHT GRAY N-7 CLAYSHALE		
										MEDIUM GRAY N5 SANDSTONE Fine to medium grain, vertical fracture.		
										LIGHT GRAY N7 CLAYSHALE		
10	NQ	35.0	45.0		10.0	61	35			MEDIUM GRAY N-5 SANDSTONE Fine to medium grain. N-6		800 gallons water used.
							40					39.2 Top of seal.
										GRAYISH RED 5R 4/2 CLAYSHALE		
11	NQ	45.0	55.0		9.9	59	45			MEDIUM GRAY N-5 TRACE OF RED CLAYSHALE		44.2 Top of sand.

AEP MT LBR LF FKA SI/GPJ AEP.GDT 7/23/15

Continued Next Page

AMERICAN ELECTRIC POWER SERVICE CORPORATION
AEP CIVIL ENGINEERING LABORATORY
 LOG OF BORING



JOB NUMBER _____

COMPANY **APPALACHIAN POWER COMPANY**

BORING NO. **96-31** DATE **7/23/15** SHEET **3** OF **7**

PROJECT **MOUNTAINEER LBR LANDFILL**

BORING START **9/11/96** BORING FINISH **9/12/96**

SAMPLE NUMBER	SAMPLE	SAMPLE DEPTH IN FEET		STANDARD PENETRATION RESISTANCE BLOWS / 6"	TOTAL LENGTH RECOVERY	RQD	DEPTH IN FEET	GRAPHIC LOG	USCS	SOIL / ROCK IDENTIFICATION	WELL	DRILLER'S NOTES
		FROM	TO			%						
							50					
12	NQ	55.0	65.0		10.0	43	55			MEDIUM DARK GRAY N-4 CLAYSHALE		
										GRAYISH RED 4-2 CLAYSHALE		
							60					
										MEDIUM GRAY N-5 CLAYSHALE		
13	NQ	65.0	75.0		10.0	85	65			MEDIUM DARK GRAY N-4 SILTY CLAYSHALE		
							70					

55.8 Top of screen.

AEP MT LBR LF FKA SI/GPJ AEP.GDT 7/23/15

Continued Next Page

AMERICAN ELECTRIC POWER SERVICE CORPORATION
AEP CIVIL ENGINEERING LABORATORY
 LOG OF BORING



JOB NUMBER _____

COMPANY **APPALACHIAN POWER COMPANY**

BORING NO. **96-31** DATE **7/23/15** SHEET **4** OF **7**

PROJECT **MOUNTAINEER LBR LANDFILL**

BORING START **9/11/96** BORING FINISH **9/12/96**

SAMPLE NUMBER	SAMPLE	SAMPLE DEPTH IN FEET		STANDARD PENETRATION RESISTANCE BLOWS / 6"	TOTAL LENGTH RECOVERY	RQD	DEPTH IN FEET	GRAPHIC LOG	USCS	SOIL / ROCK IDENTIFICATION	WELL	DRILLER'S NOTES
		FROM	TO			%						
14	NQ	75.0	85.0		10.0	82	75			MEDIUM GRAY N-5 SILTY SANDSTONE Medium to fine grain.		
15	NQ	85.0	95.0		10.0	95	85			MEDIUM GRAY N-5 CLAYSHALE Stain 89.1.		84.9 Bottom of screen. 86.0 Bottom of sand.
							90			MEDIUM GRAY N-5 CLAYSHALE		
16	NQ	95.0	105.0		9.7	81	95			MEDIUM DARK GRAY N-4 CLAYSHALE		

AEP_Mt_LBR_LF_FKA_Si/GPJ_AEP.GDT_7/23/15

Continued Next Page

AMERICAN ELECTRIC POWER SERVICE CORPORATION
AEP CIVIL ENGINEERING LABORATORY
 LOG OF BORING



JOB NUMBER _____

COMPANY **APPALACHIAN POWER COMPANY**

BORING NO. **96-31** DATE **7/23/15** SHEET **5** OF **7**

PROJECT **MOUNTAINEER LBR LANDFILL**

BORING START **9/11/96** BORING FINISH **9/12/96**

SAMPLE NUMBER	SAMPLE	SAMPLE DEPTH IN FEET		STANDARD PENETRATION RESISTANCE BLOWS / 6"	TOTAL LENGTH RECOVERY	RQD	DEPTH IN FEET	GRAPHIC LOG	USCS	SOIL / ROCK IDENTIFICATION	WELL	DRILLER'S NOTES
		FROM	TO			%						
							100			MEDIUM GRAY N-5 SANDSTONE Fine to medium grain.		
17	NQ	105.0	115.0		10.0	68	105			MEDIUM GRAY N-5 CLAYSHALE Well cemented.		
							110			MEDIUM DARK GRAY N-4 CLAYSHALE Trace of red.		
18	NQ	115.0	125.0		9.8	38	115			DARK REDDISH BROWN 10R 3/4 CLAYSHALE		
							120			MEDIUM GRAY N-5 SANDSTONE Fine grain.		
										DARK REDDISH BROWN 10R 3/4 CLAYSHALE MEDIUM DARK GRAY N-4 CLAYSHALE		
										MEDIUM GRAY N-5 SANDSTONE Fine grain.		

AEP MT LBR LF FKA SI/GPJ AEP.GDT 7/23/15

Continued Next Page

AMERICAN ELECTRIC POWER SERVICE CORPORATION
AEP CIVIL ENGINEERING LABORATORY
 LOG OF BORING



JOB NUMBER _____

COMPANY **APPALACHIAN POWER COMPANY**

BORING NO. **96-31** DATE **7/23/15** SHEET **7** OF **7**

PROJECT **MOUNTAINEER LBR LANDFILL**

BORING START **9/11/96** BORING FINISH **9/12/96**

SAMPLE NUMBER	SAMPLE	SAMPLE DEPTH IN FEET		STANDARD PENETRATION RESISTANCE BLOWS / 6"	TOTAL LENGTH RECOVERY	RQD	DEPTH IN FEET	GRAPHIC LOG	USCS	SOIL / ROCK IDENTIFICATION	WELL	DRILLER'S NOTES	
		FROM	TO			%							
22	NQ	155.0	165.0		9.9	99	155						
							160						
							165			MEDIUM DARK GRAY N-4 CLAYSHALE			
										1-29-97 SWL 85.85 DRY. 2-6-97 SWL 84.92.			

AMERICAN ELECTRIC POWER SERVICE CORPORATION
AEP CIVIL ENGINEERING LABORATORY
 LOG OF BORING



JOB NUMBER _____
 COMPANY **APPALACHIAN POWER COMPANY**
 PROJECT **MOUNTAINEER LBR LANDFILL**
 COORDINATES **N 712,296.3 E 1,700,787.8**
 GROUND ELEVATION **643.9** SYSTEM _____

BORING NO. **96-32** DATE **7/23/15** SHEET **1** OF **8**
 BORING START **9/10/96** BORING FINISH **9/20/96**
 PIEZOMETER TYPE _____ WELL TYPE **OW**
 HGT. RISER ABOVE GROUND **1.61** DIA **2.0**
 DEPTH TO TOP OF WELL SCREEN **167.8** BOTTOM **176.9**
 WELL DEVELOPMENT **YES** BACKFILL **QUICK GROUT**
 FIELD PARTY **REB-RLY** RIG **BK-81**

Water Level, ft	<input type="checkbox"/>	<input type="checkbox"/>	<input type="checkbox"/>
TIME			
DATE			

SAMPLE NUMBER	SAMPLE	SAMPLE DEPTH IN FEET		STANDARD PENETRATION RESISTANCE BLOWS / 6"	TOTAL LENGTH RECOVERY	RQD %	DEPTH IN FEET	GRAPHIC LOG	USCS	SOIL / ROCK IDENTIFICATION	WELL	DRILLER'S NOTES
		FROM	TO									
1	NQ	8.5	19.7		0		5 10 15					7000 gallons of water to drill hole. Rig and tools decon with potable water and Alconox. Cored hole from 8.5 to 19.7 soil sandy clay wash water.

TYPE OF CASING USED				<i>Continued Next Page</i>								
X	NQ-2 ROCK CORE			PIEZOMETER TYPE: PT = OPEN TUBE POROUS TIP, SS = OPEN TUBE SLOTTED SCREEN, G = GEONOR, P = PNEUMATIC								
	6" x 3.25 HSA			WELL TYPE: OW = OPEN TUBE SLOTTED SCREEN, GM = GEOMON								
	9" x 6.25 HSA			RECORDER LD								
	HW CASING ADVANCER 4"											
	NW CASING 3"											
	SW CASING 6"											
	AIR HAMMER 8"											

AEP_Mt.LBR.LF.FKA.SI.GPJ.AEP.GDT.7/23/15

AMERICAN ELECTRIC POWER SERVICE CORPORATION
AEP CIVIL ENGINEERING LABORATORY
 LOG OF BORING



JOB NUMBER _____

COMPANY **APPALACHIAN POWER COMPANY**

BORING NO. **96-32** DATE **7/23/15** SHEET **2** OF **8**

PROJECT **MOUNTAINEER LBR LANDFILL**

BORING START **9/10/96** BORING FINISH **9/20/96**

SAMPLE NUMBER	SAMPLE	SAMPLE DEPTH IN FEET		STANDARD PENETRATION RESISTANCE BLOWS / 6"	TOTAL LENGTH RECOVERY	RQD	DEPTH IN FEET	GRAPHIC LOG	USCS	SOIL / ROCK IDENTIFICATION	WELL	DRILLER'S NOTES
		FROM	TO			%						
2	NQ	19.7	20.5		.8	0				LIGHT OLIVE GRAY 5Y 5/2 SANDSTONE Well cemented		
3	NQ	20.5	30.5		9.8					MEDIUM BLUIISH GRAY 5B 5/1 SANDSTONE Hard.		
							25			DUSKY YELLOWISH 5Y6/4 CLAYSHALE		
										MEDIUM BLUIISH GRAY 5B 5/1 SANDSTONE Hard.		
4	NQ	30.5	40.5		10.0	30				PALE REDDISH BROWN 10R 5/4 CLAYSHALE		
							35					
							40			MODERATE REDDISH BROWN 10R 4/6 CLAYSHALE		
5	NQ	40.5	50.5		10.0							
							45			MEDIUM BLUIISH GRAY CLAYSHALE		

AEP MT LBR LF FKA SI/GPJ AEP.GDT 7/23/15

Continued Next Page

AMERICAN ELECTRIC POWER SERVICE CORPORATION
AEP CIVIL ENGINEERING LABORATORY
 LOG OF BORING



JOB NUMBER _____

COMPANY **APPALACHIAN POWER COMPANY**

BORING NO. **96-32** DATE **7/23/15** SHEET **3** OF **8**

PROJECT **MOUNTAINEER LBR LANDFILL**

BORING START **9/10/96** BORING FINISH **9/20/96**

SAMPLE NUMBER	SAMPLE	SAMPLE DEPTH IN FEET		STANDARD PENETRATION RESISTANCE BLOWS / 6"	TOTAL LENGTH RECOVERY	RQD	DEPTH IN FEET	GRAPHIC LOG	USCS	SOIL / ROCK IDENTIFICATION	WELL	DRILLER'S NOTES
		FROM	TO			%						
6	NQ	50.5	60.5		10.0	90	50			MEDIUM LIGHT GRAY N-6 SANDY SHALE		
							55			MEDIUM LIGHT GRAY N-6 CLAYSHALE		
7	NQ	60.5	70.5		10.0	70	60			GRAYISH RED 10R 4/2 CLAYSHALE		
							65					
8	NQ	70.5	80.5		7.8	0	70			MIXED 5B 5/1 GRAY, RED CLAYSHALE		

AEP_Mt.LBR.LF.FKA.SI.GPJ_AEP.GDT_7/23/15

Continued Next Page

AMERICAN ELECTRIC POWER SERVICE CORPORATION
AEP CIVIL ENGINEERING LABORATORY
 LOG OF BORING



JOB NUMBER _____

COMPANY **APPALACHIAN POWER COMPANY**

BORING NO. **96-32** DATE **7/23/15** SHEET **4** OF **8**

PROJECT **MOUNTAINEER LBR LANDFILL**

BORING START **9/10/96** BORING FINISH **9/20/96**

SAMPLE NUMBER	SAMPLE	SAMPLE DEPTH IN FEET		STANDARD PENETRATION RESISTANCE BLOWS / 6"	TOTAL LENGTH RECOVERY	RQD	DEPTH IN FEET	GRAPHIC LOG	USCS	SOIL / ROCK IDENTIFICATION	WELL	DRILLER'S NOTES
		FROM	TO			%						
							75					
9	NQ	80.5	90.5		10.0	100	80			MEDIUM BLUIISH GRAY 5B 5:1 SANDY SHALE		
							85			GRAY N-6 SANDSTONE Shale lens, well cemented.		
10	NQ	90.5	100.5		10.0	100	90			Hard, massive		
							95					

AEP MT LBR LF FKA SI/GPJ AEP.GDT 7/23/15

Continued Next Page

AMERICAN ELECTRIC POWER SERVICE CORPORATION
AEP CIVIL ENGINEERING LABORATORY
 LOG OF BORING



JOB NUMBER _____

COMPANY **APPALACHIAN POWER COMPANY**

BORING NO. **96-32** DATE **7/23/15** SHEET **5** OF **8**

PROJECT **MOUNTAINEER LBR LANDFILL**

BORING START **9/10/96** BORING FINISH **9/20/96**

SAMPLE NUMBER	SAMPLE	SAMPLE DEPTH IN FEET		STANDARD PENETRATION RESISTANCE BLOWS / 6"	TOTAL LENGTH RECOVERY	RQD	DEPTH IN FEET	GRAPHIC LOG	USCS	SOIL / ROCK IDENTIFICATION	WELL	DRILLER'S NOTES
		FROM	TO			%						
11	NQ	100.5	110.5		10.0	100	100					
							105					
12	NQ	110.5	120.5		8.6	20	110			Limestone nodules.		
							115			MEDIUM BLUIISH GRAY 5B 5:1 CLAYSHALE Badly broken, high angle fracture.		
13	NQ	120.5	130.5		10.0	97	120			MEDIUM GRAY N-5 CLAYSHALE		
										LIGHT GRAY N-6 SANDSTONE Shale lens, soft gray clay seam 123.8-124.2.		

AEP MT LBR LF FKA SJ/GPJ AEP.GDT 7/23/15

Continued Next Page

AMERICAN ELECTRIC POWER SERVICE CORPORATION
AEP CIVIL ENGINEERING LABORATORY
 LOG OF BORING



JOB NUMBER _____

COMPANY **APPALACHIAN POWER COMPANY**

BORING NO. **96-32** DATE **7/23/15** SHEET **6** OF **8**

PROJECT **MOUNTAINEER LBR LANDFILL**

BORING START **9/10/96** BORING FINISH **9/20/96**

SAMPLE NUMBER	SAMPLE	SAMPLE DEPTH IN FEET		STANDARD PENETRATION RESISTANCE BLOWS / 6"	TOTAL LENGTH RECOVERY	RQD	DEPTH IN FEET	GRAPHIC LOG	USCS	SOIL / ROCK IDENTIFICATION	WELL	DRILLER'S NOTES
		FROM	TO			%						
							125					
14	NQ	130.5	140.5		10.0	100	130			LIGHT GRAY N-7 SANDSTONE Hard, coarse. MEDIUM LIGHT GRAY SANDSTONE Shale lens		
							135					
15	NQ	140.5	150.5		10.0	100	140			LIGHT GRAY N-7 SANDSTONE Coarse grain, hard.		
							145					
							150					

AEP MT LBR LF FKA SI/GPJ AEP.GDT 7/23/15

Continued Next Page

AMERICAN ELECTRIC POWER SERVICE CORPORATION
AEP CIVIL ENGINEERING LABORATORY
 LOG OF BORING



JOB NUMBER _____

COMPANY **APPALACHIAN POWER COMPANY**

BORING NO. **96-32** DATE **7/23/15** SHEET **7** OF **8**

PROJECT **MOUNTAINEER LBR LANDFILL**

BORING START **9/10/96** BORING FINISH **9/20/96**

SAMPLE NUMBER	SAMPLE	SAMPLE DEPTH IN FEET		STANDARD PENETRATION RESISTANCE BLOWS / 6"	TOTAL LENGTH RECOVERY	RQD	DEPTH IN FEET	GRAPHIC LOG	USCS	SOIL / ROCK IDENTIFICATION	WELL	DRILLER'S NOTES
		FROM	TO			%						
16	NQ	150.5	160.5		10.0	100	155					
							160			MEDIUM GRAY SANDY SHALE		
17	NQ	160.5	170.5		10.0	86	165			GRAY BLACK N-2 CLAYSHALE		160.8 Top of seal.
							170			BLACK COAL		166.0 Top of sand.
18	NQ	170.5	180.5		10.0	59	175			DARK GRAY N-3 CLAYSHALE		167.8 Top of screen.

AEP MT LBR LF FKA SI/GPJ AEP.GDT 7/23/15

Continued Next Page

AMERICAN ELECTRIC POWER SERVICE CORPORATION
AEP CIVIL ENGINEERING LABORATORY
 LOG OF BORING



JOB NUMBER _____

COMPANY **APPALACHIAN POWER COMPANY**

BORING NO. **96-32** DATE **7/23/15** SHEET **8** OF **8**

PROJECT **MOUNTAINEER LBR LANDFILL**

BORING START **9/10/96** BORING FINISH **9/20/96**

SAMPLE NUMBER	SAMPLE	SAMPLE DEPTH IN FEET		STANDARD PENETRATION RESISTANCE BLOWS / 6"	TOTAL LENGTH RECOVERY	RQD	DEPTH IN FEET	GRAPHIC LOG	U S C S	SOIL / ROCK IDENTIFICATION	WELL	DRILLER'S NOTES
		FROM	TO			%						
												176.9 Bottom of screen. 178.0 Bottom of sand.
19	NQ	180.5	190.5		10.0		180			MEDIUM GRAY N-5 SANDSTONE Shale lens.		
							185			DARK GRAY CLAYSHALE		
							190			1-21-97 SWL 132.0 pH COND TEMP GALLONS SWL 7.96 1028 56 2.0 146.5. 8.75 960 27 2.0 154. 8.59 837 59 2.0 163.0. 8.78 829 60 2.0 164.5. 816 1283 58 2.0 170.0. 798 1421 57 2.0 -. WELL RECOVERED 2500 ML IN 20 MIN. 1-22-97 SWL 131.9. 8.12 2880 54 2.0 147.2. 8.00 2750 56 2.0 156.3. 7.85 3500 56 2.0 157.0. 1-23-97 SWL 132.1 PUMPED WELL TO 175' WITH ONE TEST pH 7.68 COND. 772 PUMP STOPPED RUNNING. 2-6-97 SWL 132.0'		

AMERICAN ELECTRIC POWER SERVICE CORPORATION
AEP CIVIL ENGINEERING LABORATORY
 LOG OF BORING



JOB NUMBER _____

COMPANY **APPALACHIAN POWER COMPANY**

BORING NO. **96-33** DATE **7/23/15** SHEET **2** OF **2**

PROJECT **MOUNTAINEER LBR LANDFILL**

BORING START **1/21/97** BORING FINISH **1/23/97**

SAMPLE NUMBER	SAMPLE	SAMPLE DEPTH IN FEET		STANDARD PENETRATION RESISTANCE BLOWS / 6"	TOTAL LENGTH RECOVERY	RQD	DEPTH IN FEET	GRAPHIC LOG	U S C S	SOIL / ROCK IDENTIFICATION	WELL	DRILLER'S NOTES
		FROM	TO			%						
6	NQ	20.2	25.2		4.8	82				BLUIISH GRAY CLAYSHALE Hard. BLUIISH GRAY AND RED CLAYSHALE BLUIISH GRAY CLAYSHALE Hard, fractures at 28.5, 30.6, 31.4, 32.8 soft, 30.8, 31.4 shaley sandstone.		20.0 Top of sand. 21.0 Top of screen.
7	NQ	25.2	35.2		10.0	92	25			BLUIISH GRAY SANDY SHALE		
							30					
8	NQ	35.2	40.2		5.0	100	35			GRAY SANDY SHALE		
										GRAY AND SILVER SANDSTONE Shale lens.		
										GRAY SANDY SHALE		
										GRAY AND SILVER SANDSTONE Shale lens.		
							40			pH 8.68 COND. 635 TEMP. 56 HI. 2:40 4.04'. HI. 3:40 3.94. HI. 4:00 3.91. HI. 4:15 3.87. 1-30-97 1375 ML/MIN. ARTESIAN.		40.0 Bottom of screen. 41.1 Bottom of sand.

AEP MT LBR LF FKA SI/GPJ AEP.GDT 7/23/15



AEP 2005

Boring Logs

B0501 & B0502

AMERICAN ELECTRIC POWER SERVICE CORPORATION
AEP CIVIL ENGINEERING LABORATORY
 LOG OF BORING



JOB NUMBER _____
 COMPANY **APPALACHIAN POWER COMPANY**
 PROJECT **MOUNTAINEER LBR LANDFILL**
 COORDINATES **N 713,381.3 E 1,733,671.6**
 GROUND ELEVATION **797.6** SYSTEM State Plane using NAD27

BORING NO. **B0501** DATE **7/23/15** SHEET **1** OF **14**
 BORING START **6/23/05** BORING FINISH **6/29/05**
 PIEZOMETER TYPE _____ WELL TYPE _____
 HGT. RISER ABOVE GROUND _____ DIA _____
 DEPTH TO TOP OF WELL SCREEN _____ BOTTOM _____
 WELL DEVELOPMENT _____ BACKFILL **QUICK GROUT**
 FIELD PARTY **MCR / CB** RIG **BK-81**

Water Level, ft	<input type="checkbox"/>	<input type="checkbox"/>	<input type="checkbox"/>
TIME			
DATE			

SAMPLE NUMBER	SAMPLE	SAMPLE DEPTH IN FEET		STANDARD PENETRATION RESISTANCE BLOWS / 6"	TOTAL LENGTH RECOVERY	RQD %	DEPTH IN FEET	GRAPHIC LOG	USCS	SOIL / ROCK IDENTIFICATION	WELL	DRILLER'S NOTES
		FROM	TO									
	AUGER	0.0	1.8									
1	SS	1.8	3.3	2-4-7	1.1		5			STIFF 10YR 6/6 DARK YELLOWISH ORANGE SILTY CLAY 3.0 tsf, Dry		Digging permit required and in hand. Grounding procedures not in use on this boring. Using well / fire protection water from Mountaineer Plant to drill with. Deconned on 06/23/05 using Mountaineer water and liqui-nox. Auger & spoon refusal @ 9.6'
2	SS	6.8	7.1	50/3	0.2					HARD 10YR 7/4 GRAYISH ORANGE WEATHERED FINE GRAIN SANDY CLAY SHALE		
3	NQ2	9.6	15.1		5.6	0	10			10YR 7/4 GRAYISH ORANGE SILTY CLAY SHALE Iron Staining @ 11.2'-11.4' Broken Area @ 17.2'-17.8'		
4	NQ2	15.1	25.1		6.9	7	15					

TYPE OF CASING USED

<input checked="" type="checkbox"/>	NQ-2 ROCK CORE
<input checked="" type="checkbox"/>	6" x 3.25 HSA
	9" x 6.25 HSA
	HW CASING ADVANCER 4"
	NW CASING 3"
	SW CASING 6"
	AIR HAMMER 8"

Continued Next Page

PIEZOMETER TYPE: PT = OPEN TUBE POROUS TIP, SS = OPEN TUBE SLOTTED SCREEN, G = GEONOR, P = PNEUMATIC
 WELL TYPE: OW = OPEN TUBE SLOTTED SCREEN, GM = GEOMON

RECORDER **CB**

AMERICAN ELECTRIC POWER SERVICE CORPORATION
AEP CIVIL ENGINEERING LABORATORY
 LOG OF BORING



JOB NUMBER _____

COMPANY **APPALACHIAN POWER COMPANY**

BORING NO. **B0501** DATE **7/23/15** SHEET **2** OF **14**

PROJECT **MOUNTAINEER LBR LANDFILL**

BORING START **6/23/05** BORING FINISH **6/29/05**

SAMPLE NUMBER	SAMPLE	SAMPLE DEPTH IN FEET		STANDARD PENETRATION RESISTANCE BLOWS / 6"	TOTAL LENGTH RECOVERY	RQD	DEPTH IN FEET	GRAPHIC LOG	USCS	SOIL / ROCK IDENTIFICATION	WELL	DRILLER'S NOTES
		FROM	TO			%						
5	NQ2	25.1	30.1		2.3	48	25			5B 7/1 LIGHT BLuish GRAY CLAY SHALE Broken Area @ 27.1'		SWL @ 22.4' on 6/24/05 w/ NQ hole to 60.1'
6	NQ2	30.1	40.1		5.8	9	30			SOFT 5YR 8/4 MODERATE BROWN CLAY		
							35			5B 5/1 MEDIUM BLuish GRAY CLAY SHALE		
7	NQ2	40.1	50.1		9.7	96	40			10YR 6/2 PALE YELLOWISH BROWN FINE to MEDIUM GRAIN SANDSTONE		
							45					

AEP MT LBR LF FKA SI/GPJ AEP.GDT 7/23/15

Continued Next Page

AMERICAN ELECTRIC POWER SERVICE CORPORATION
AEP CIVIL ENGINEERING LABORATORY
 LOG OF BORING



JOB NUMBER _____

COMPANY **APPALACHIAN POWER COMPANY**

BORING NO. **B0501** DATE **7/23/15** SHEET **3** OF **14**

PROJECT **MOUNTAINEER LBR LANDFILL**

BORING START **6/23/05** BORING FINISH **6/29/05**

SAMPLE NUMBER	SAMPLE	SAMPLE DEPTH IN FEET		STANDARD PENETRATION RESISTANCE BLOWS / 6"	TOTAL LENGTH RECOVERY	RQD	DEPTH IN FEET	GRAPHIC LOG	USCS	SOIL / ROCK IDENTIFICATION	WELL	DRILLER'S NOTES
		FROM	TO			%						
8	NQ2	50.1	60.1		9.6	80	50					
										SOFT 5B 5/1 MEDIUM BLUISH GRAY CLAY SHALE		
										10YR 6/1 PALE YELLOWISH BROWN FINE to MEDIUM GRAIN SANDSTONE		
							55					
9	NQ2	60.1	70.1		9.5	100	60			10YR 6/1 PALE YELLOWISH BROWN FINE to MEDIUM GRAIN SANDSTONE w/ coal streaks throughout		1500 gallons of water used to this point - 60.1'
												SWL @ 62.2' on 6/27/05 w/ NQ hole to 120.1'
							65					
												SWL @ 68.2' on 6/28/05 w/ NQ hole to 180.1'; 12 hr reading
10	NQ2	70.1	80.1		9.6	74	70			5Y 6/1 LIGHT OLIVE GRAY COARSE GRAIN SANDSTONE		

AEP_Mt_LBR_LF_FKA_SiG_PJ_AEP_GDT_7/23/15

Continued Next Page

AMERICAN ELECTRIC POWER SERVICE CORPORATION
AEP CIVIL ENGINEERING LABORATORY
 LOG OF BORING



JOB NUMBER _____

COMPANY **APPALACHIAN POWER COMPANY**

BORING NO. **B0501** DATE **7/23/15** SHEET **4** OF **14**

PROJECT **MOUNTAINEER LBR LANDFILL**

BORING START **6/23/05** BORING FINISH **6/29/05**

SAMPLE NUMBER	SAMPLE	SAMPLE DEPTH IN FEET		STANDARD PENETRATION RESISTANCE BLOWS / 6"	TOTAL LENGTH RECOVERY	RQD	DEPTH IN FEET	GRAPHIC LOG	USCS	SOIL / ROCK IDENTIFICATION	WELL	DRILLER'S NOTES
		FROM	TO			%						
							75			5B 5/1 MEDIUM BLuish GRAY CLAY SHALE High angle fracture @ 73.9' - 70 degrees from horizontal w/ iron staining Soft area @ 74.6'-75.8' w/ iron staining		
11	NQ2	80.1	90.1		9.0	61	80			High angle fracture @ 81.3' - 80 degrees from horizontal		
							85			Broken area w/ iron staining @ 85.2'-86.9' High angle fracture @ 86.9' - 40 degrees from horizontal		
12	NQ2	90.1	100.1		9.8	91	90			High angle fracture @ 86.9' - 85 degrees from horizontal		
							95			Broken area w/ iron staining @ 94.8'		

AEP MT LBR LF FKA SI/GPJ AEP.GDT 7/23/15

Continued Next Page

AMERICAN ELECTRIC POWER SERVICE CORPORATION
AEP CIVIL ENGINEERING LABORATORY
 LOG OF BORING



JOB NUMBER _____

COMPANY **APPALACHIAN POWER COMPANY**

BORING NO. **B0501** DATE **7/23/15** SHEET **5** OF **14**

PROJECT **MOUNTAINEER LBR LANDFILL**

BORING START **6/23/05** BORING FINISH **6/29/05**

SAMPLE NUMBER	SAMPLE	SAMPLE DEPTH IN FEET		STANDARD PENETRATION RESISTANCE BLOWS / 6"	TOTAL LENGTH RECOVERY	RQD	DEPTH IN FEET	GRAPHIC LOG	USCS	SOIL / ROCK IDENTIFICATION	WELL	DRILLER'S NOTES
		FROM	TO			%						
13	NQ2	100.1	110.1		9.2	88	100					
										SOFT 5YR 4/4 MODERATE BROWN CLAY SHALE		
							105			5B 5/1 MEDIUM BLUISH GRAY CLAY SHALE		
14	NQ2	110.1	120.1		9.3	84	110					
										High angle fracture @ 112.6' - 50 degrees from horizontal High angle fracture @ 113.5' - 50 degrees from horizontal		
							115			High angle fracture @ 115.2' - 85 degrees from horizontal		
										5YR 4/4 MODERATE BROWN CLAY SHALE		
										5B 5/1 MEDIUM BLUISH GRAY CLAY SHALE		
15	NQ2	120.1	130.1		9.6	88	120					
												SWL @ 119.8' on 6/29/05 w/ NQ hole to 310.1' 3500 gallons of water used to this point - 120.1'

AEP_Mt.LBR.LF.FKA.SI.GPJ_AEP.GDT_7/23/15

Continued Next Page

AMERICAN ELECTRIC POWER SERVICE CORPORATION
AEP CIVIL ENGINEERING LABORATORY
 LOG OF BORING



JOB NUMBER _____

COMPANY **APPALACHIAN POWER COMPANY**

BORING NO. **B0501** DATE **7/23/15** SHEET **6** OF **14**

PROJECT **MOUNTAINEER LBR LANDFILL**

BORING START **6/23/05** BORING FINISH **6/29/05**

SAMPLE NUMBER	SAMPLE	SAMPLE DEPTH IN FEET		STANDARD PENETRATION RESISTANCE BLOWS / 6"	TOTAL LENGTH RECOVERY	RQD	DEPTH IN FEET	GRAPHIC LOG	USCS	SOIL / ROCK IDENTIFICATION	WELL	DRILLER'S NOTES
		FROM	TO			%						
							125			5YR 4/1 BROWNISH GRAY CLAY SHALE		
16	NQ2	130.1	140.1		9.4	70	130			High angle fracture @ 129.2' - 40 degrees from horizontal High angle fracture @ 129.8' - 35 degrees from horizontal		
							135			High angle fracture @ 134.9' - 40 degrees from horizontal High angle fracture @ 136.1' - 40 degrees from horizontal Horizontal soft area @ 138.1'		
17	NQ2	140.1	150.1		9.7	100	140			5B 5/1 MEDIUM BLUISH GRAY CLAY SHALE High angle fracture @ 139.4' - 35 degrees from horizontal 5B 5/1 MEDIUM BLUISH GRAY SILTY CLAY SHALE		
							145			High angle fracture @ 143.9' - 75 degrees from horizontal		

AEP_Mt.LBR.LF.FKA.SI.GPJ_AEP.GDT_7/23/15

Continued Next Page

AMERICAN ELECTRIC POWER SERVICE CORPORATION
AEP CIVIL ENGINEERING LABORATORY
 LOG OF BORING



JOB NUMBER _____

COMPANY **APPALACHIAN POWER COMPANY**

BORING NO. **B0501** DATE **7/23/15** SHEET **7** OF **14**

PROJECT **MOUNTAINEER LBR LANDFILL**

BORING START **6/23/05** BORING FINISH **6/29/05**

SAMPLE NUMBER	SAMPLE	SAMPLE DEPTH IN FEET		STANDARD PENETRATION RESISTANCE BLOWS / 6"	TOTAL LENGTH RECOVERY	RQD		DEPTH IN FEET	GRAPHIC LOG	USCS	SOIL / ROCK IDENTIFICATION	WELL	DRILLER'S NOTES
		FROM	TO			%							
18	NQ2	150.1	160.1		9.0			155			SOFT 5B 5/1 BROWNISH GRAY CLAY SHALE Broken area @ 157.2'		
								160					
19	NQ2	160.1	170.1		9.6	79		165			5B 5/1 MEDIUM BLUISH GRAY SILTY CLAY SHALE		
								170					
20	NQ2	170.1	180.1		9.9	100		175					

AEP_Mt.LBR.LF.FKA.SI.GPJ_AEP.GDT_7/23/15

Continued Next Page

AMERICAN ELECTRIC POWER SERVICE CORPORATION
AEP CIVIL ENGINEERING LABORATORY
 LOG OF BORING



JOB NUMBER _____

COMPANY **APPALACHIAN POWER COMPANY**

BORING NO. **B0501** DATE **7/23/15** SHEET **8** OF **14**

PROJECT **MOUNTAINEER LBR LANDFILL**

BORING START **6/23/05** BORING FINISH **6/29/05**

SAMPLE NUMBER	SAMPLE	SAMPLE DEPTH IN FEET		STANDARD PENETRATION RESISTANCE BLOWS / 6"	TOTAL LENGTH RECOVERY	RQD	DEPTH IN FEET	GRAPHIC LOG	USCS	SOIL / ROCK IDENTIFICATION	WELL	DRILLER'S NOTES
		FROM	TO			%						
21	NQ2	180.1	190.1		9.6	96	180					5500 gallons of water used to this point - 180.1'
							185			High angle fracture @ 184.2' - 65 degrees from horizontal		
							190			High angle fracture @ 187.7' - 55 degrees from horizontal		
22	NQ2	190.1	195.1		3.7	54	190			5R 4/2 GRAYISH RED CLAY SHALE Soft area @ 190.2'		
							195			Soft area @ 192.6'		
23	NQ2	195.1	205.1		10	79	195					
							200			High angle fracture @ 198.7' - 40 degrees from horizontal High angle fracture @ 199.1' - 40 degrees from horizontal High angle fracture @ 200.1' - 40 degrees from horizontal		

AEP_Mt.LBR.LF.FKA.SI.GPJ_AEP.GDT_7/23/15

Continued Next Page

AMERICAN ELECTRIC POWER SERVICE CORPORATION
AEP CIVIL ENGINEERING LABORATORY
 LOG OF BORING



JOB NUMBER _____

COMPANY **APPALACHIAN POWER COMPANY**

BORING NO. **B0501** DATE **7/23/15** SHEET **9** OF **14**

PROJECT **MOUNTAINEER LBR LANDFILL**

BORING START **6/23/05** BORING FINISH **6/29/05**

SAMPLE NUMBER	SAMPLE	SAMPLE DEPTH IN FEET		STANDARD PENETRATION RESISTANCE BLOWS / 6"	TOTAL LENGTH RECOVERY	RQD	DEPTH IN FEET	GRAPHIC LOG	USCS	SOIL / ROCK IDENTIFICATION	WELL	DRILLER'S NOTES
		FROM	TO			%						
										5B 5/1 MEDIUM BLuish GRAY SILTY CLAY SHALE High angle fracture @ 202.5' - 65 degrees from horizontal		
24	NQ2	205.1	215.1		8.2	100	205					
							210					
25	NQ2	215.1	223.1		9.2	64	215					Picked up 1.1' from previous run.
										5R 4/2 GRAYISH RED CLAY SHALE Broken area @ 221.9'-222.4' High angle fracture @ 224.6' - 25 degrees from horizontal High angle fracture @ 225.7' - 30 degrees from horizontal High angle fracture @ 226.7' - 40 degrees from horizontal High angle fracture @ 227.1' - 45 degrees from		
							220					
26	NQ2	223.1	230.1		6.2	47	225					

AEP_Mt.LBR.LF.FKA.SI.GPJ.AEP.GDT.7/23/15

Continued Next Page

AMERICAN ELECTRIC POWER SERVICE CORPORATION
AEP CIVIL ENGINEERING LABORATORY
 LOG OF BORING



JOB NUMBER _____

COMPANY **APPALACHIAN POWER COMPANY**

BORING NO. **B0501** DATE **7/23/15** SHEET **10** OF **14**

PROJECT **MOUNTAINEER LBR LANDFILL**

BORING START **6/23/05** BORING FINISH **6/29/05**

SAMPLE NUMBER	SAMPLE	SAMPLE DEPTH IN FEET		STANDARD PENETRATION RESISTANCE BLOWS / 6"	TOTAL LENGTH RECOVERY	RQD	DEPTH IN FEET	GRAPHIC LOG	USCS	SOIL / ROCK IDENTIFICATION	WELL	DRILLER'S NOTES
		FROM	TO			%						
							230			horizontal		7500 gallons of water used to this point - 230.1'
27	NQ2	230.1	240.1		8.9	64				5B 5/1 MEDIUM BLUISH GRAY SILTY CLAY SHALE		
							235			236.9'-239.7' - Clayey Limestone w/ secondary calcite fractures		
							240			5B 5/1 MEDIUM BLUISH GRAY FINE GRAIN SILTY SANDSTONE Fine laminar bedding, grading to current ripple bedding w/ increasing depth		
							245					
							250					
28	NQ2	240.1	250.1		9.9	100						
29	NQ2	250.1	260.1		10.0	83						

AEP MT LBR LF FKA SI/GPJ AEP.GDT 7/23/15

Continued Next Page

AMERICAN ELECTRIC POWER SERVICE CORPORATION
AEP CIVIL ENGINEERING LABORATORY
 LOG OF BORING



JOB NUMBER _____

COMPANY **APPALACHIAN POWER COMPANY**

BORING NO. **B0501** DATE **7/23/15** SHEET **11** OF **14**

PROJECT **MOUNTAINEER LBR LANDFILL**

BORING START **6/23/05** BORING FINISH **6/29/05**

SAMPLE NUMBER	SAMPLE	SAMPLE DEPTH IN FEET		STANDARD PENETRATION RESISTANCE BLOWS / 6"	TOTAL LENGTH RECOVERY	RQD	DEPTH IN FEET	GRAPHIC LOG	USCS	SOIL / ROCK IDENTIFICATION	WELL	DRILLER'S NOTES
		FROM	TO			%						
							255			5R 4/2 GRAYISH RED CLAY SHALE		
							255			5B 5/1 MEDIUM BLUISH GRAY FINE GRAIN SILTY SANDSTONE laminar to current ripple cross bedding, micaceous nodular limestone w/ maroon mottles		
30	NQ2	260.1	270.1				260			5B 5/1 MEDIUM BLUISH GRAY FINE GRAIN SANDSTONE		
										Broken area @ 263.5'-264.1'		
							265			5R 4/2 GRAYISH RED SILTY CLAY SHALE		
							270			5B 5/1 MEDIUM BLUISH GRAY FINE GRAIN SANDSTONE High angle fracture @ 272.9' - 45 degrees from horizontal Broken area @ 273.8'-274.9'		
31	NQ2	270.1	280.1		9.7	80	270					
							275					

AEP_Mt.LBR.LF.FKA.SI.GPJ_AEP.GDT_7/23/15

Continued Next Page

AMERICAN ELECTRIC POWER SERVICE CORPORATION
AEP CIVIL ENGINEERING LABORATORY
 LOG OF BORING



JOB NUMBER _____

COMPANY **APPALACHIAN POWER COMPANY**

BORING NO. **B0501** DATE **7/23/15** SHEET **12** OF **14**

PROJECT **MOUNTAINEER LBR LANDFILL**

BORING START **6/23/05** BORING FINISH **6/29/05**

SAMPLE NUMBER	SAMPLE	SAMPLE DEPTH IN FEET		STANDARD PENETRATION RESISTANCE BLOWS / 6"	TOTAL LENGTH RECOVERY	RQD	DEPTH IN FEET	GRAPHIC LOG	USCS	SOIL / ROCK IDENTIFICATION	WELL	DRILLER'S NOTES
		FROM	TO			%						
32	NQ2	280.1	290.1		9.7	100				5B 7/1 LIGHT BLuish GRAY FINE to MEDIUM GRAIN SANDSTONE Coal streaks throughout		9500 gallons of water used to this point - 280.1'
							285					
							290					
33	NQ2	290.1	300.1		10.0	100						
							295					
							300					
34	NQ2	300.1	310.1		9.0	96						
							305			5B 7/1 LIGHT BLuish GRAY SILTY CLAY SHALE		

AEP MT LBR LF FKA SI/GPJ AEP.GDT 7/23/15

Continued Next Page

AMERICAN ELECTRIC POWER SERVICE CORPORATION
AEP CIVIL ENGINEERING LABORATORY
 LOG OF BORING



JOB NUMBER _____

COMPANY **APPALACHIAN POWER COMPANY**

BORING NO. **B0501** DATE **7/23/15** SHEET **13** OF **14**

PROJECT **MOUNTAINEER LBR LANDFILL**

BORING START **6/23/05** BORING FINISH **6/29/05**

SAMPLE NUMBER	SAMPLE	SAMPLE DEPTH IN FEET		STANDARD PENETRATION RESISTANCE BLOWS / 6"	TOTAL LENGTH RECOVERY	RQD	DEPTH IN FEET	GRAPHIC LOG	USCS	SOIL / ROCK IDENTIFICATION	WELL	DRILLER'S NOTES
		FROM	TO			%						
										Coal streaks throughout 5B 7/1 LIGHT BLuish GRAY FINE to MEDIUM GRAIN SANDSTONE		
35	NQ2	310.1	320.1		10.2	100	310					Picked up 0.2' from previous run.
							315					
							320			5B 7/1 LIGHT BLuish GRAY FINE to MEDIUM GRAIN SANDSTONE Coal streaks throughout		
36	NQ2	320.1	330.1		9.9	100	320					
							325			0.05' Clay Shale lense @ 326.9'		
							330			5B 7/1 LIGHT BLuish GRAY FINE to MEDIUM GRAIN SANDSTONE		
37	NQ2	330.1	340.1		10.0	67	330					

AEP_Mt_LBR_LF_FKA_Si_GPJ_AEP_GDT_7/23/15

Continued Next Page

AMERICAN ELECTRIC POWER SERVICE CORPORATION
AEP CIVIL ENGINEERING LABORATORY
 LOG OF BORING



JOB NUMBER _____

COMPANY **APPALACHIAN POWER COMPANY**

BORING NO. **B0501** DATE **7/23/15** SHEET **14** OF **14**

PROJECT **MOUNTAINEER LBR LANDFILL**

BORING START **6/23/05** BORING FINISH **6/29/05**

SAMPLE NUMBER	SAMPLE	SAMPLE DEPTH IN FEET		STANDARD PENETRATION RESISTANCE BLOWS / 6"	TOTAL LENGTH RECOVERY	RQD	DEPTH IN FEET	GRAPHIC LOG	USCS	SOIL / ROCK IDENTIFICATION	WELL	DRILLER'S NOTES
		FROM	TO			%						
							335			HARD SILTY CLAY SHALE N1 BLACK COAL		
										337.8'-338.1' - Fractures w/ calcite fill		
							340			HARD CLAY SHALE		
38	NQ2	340.1	350.1		9.8	100				5B 5/1 MEDIUM BLUISH GRAY CLAY SHALE Carbonaceous, fossil stems, pyrite		
							345					
							350					
												Stopped boring @ 350.1' on 6/29/05. Flushed boring with approx. 1000 gallons of water. Boring geo-physical logged on 6/29/05. Installation of 1" geomon well (MW-41) will be done at a later date.

AMERICAN ELECTRIC POWER SERVICE CORPORATION
AEP CIVIL ENGINEERING LABORATORY
 LOG OF BORING



JOB NUMBER _____
 COMPANY **APPALACHIAN POWER COMPANY**
 PROJECT **MOUNTAINEER LBR LANDFILL**
 COORDINATES **N 713,726.5 E 1,732,783.6**
 GROUND ELEVATION **627.7** SYSTEM State Plane using NAD27

BORING NO. **B0502** DATE **7/23/15** SHEET **1** OF **11**
 BORING START **1/4/05** BORING FINISH **6/23/05**
 PIEZOMETER TYPE _____ WELL TYPE **GM**
 HGT. RISER ABOVE GROUND _____ DIA **1"**
 DEPTH TO TOP OF WELL SCREEN _____ BOTTOM _____
 WELL DEVELOPMENT _____ BACKFILL **BENSEAL**
 FIELD PARTY **MCR / CB** RIG **BK-81**

Water Level, ft	▽ 3.8	▼ 3.8	▽ 4.1
TIME	8:00AM	12:30PM	8:30AM
DATE	1/5/05	1/11/05	1/13/05

SAMPLE NUMBER	SAMPLE	SAMPLE DEPTH IN FEET		STANDARD PENETRATION RESISTANCE BLOWS / 6"	TOTAL LENGTH RECOVERY	RQD %	DEPTH IN FEET	GRAPHIC LOG	USCS	SOIL / ROCK IDENTIFICATION	WELL	DRILLER'S NOTES
		FROM	TO									
1	SS	0.0	1.5	2-3-3	0.8					MEDIUM STIFF 5YR 5/6 LIGHT BROWN SILTY CLAY 3.5 tsf, moist	▼ Grounding procedures not in use on this boring. Using well / fire protection water from Mountaineer Plant to drill with. Deconned on 01/04/05 using Mountaineer water and liqui-nox with drill pump. SWL @ 3.8' on 1/5/05 with HSA's to 24.0' SWL @ 3.8' on 1/11/05 with HSA's on bedrock. SWL @ 4.1' on 1/13/05 with NQ hole to 183.2' SWL @ 7.1' on 6/23/05 with NQ hole to 230.2'	
2	SS	1.5	3.0	2-2-3	0.6				MEDIUM STIFF 5YR 5/6 LIGHT BROWN SILTY CLAY 1.5 tsf, w/ trace of fine sand, moist			
3	SS	3.0	4.5	1-2-2	0.5							
4	SS	4.5	6.0	2-5-7	1.5		5		STIFF 5YR 5/6 LIGHT BROWN CLAY 1.75 tsf, moist			
5	SS	6.0	7.5	2-5-7	1.5							
6	SS	7.5	9.0	1-3-5	1.5				STIFF 5YR 5/6 LIGHT BROWN CLAY 1.25 tsf, moist			
7	SS	9.0	10.5	2-4-5	1.5		10		STIFF 5YR 5/6 LIGHT BROWN CLAY 2.0 tsf, moist			
8	SS	10.5	12.0	2-3-6	1.5				STIFF 10YR 6/2 PALE YELLOWISH BROWN CLAY 1.75 tsf, moist			
9	SS	12.0	13.5	2-4-6	1.4				STIFF 10YR 6/2 PALE YELLOWISH BROWN CLAY 1.5 tsf, moist			
10	SS	13.5	15.0	2-5-6	1.5				STIFF 10YR 6/2 PALE YELLOWISH BROWN CLAY 2.25 tsf, moist			
11	SS	15.0	16.5	3-3-5	1.4		15		STIFF 5G 6/1 GREENISH GRAY CLAY 1.75 tsf, w/ trace of fine sand, moist			
12	SS	16.5	18.0	3-5-7	1.0				STIFF 10YR 6/6 DARK YELLOWISH ORANGE CLAY 1.5 tsf, moist			
13	SS	18.0	19.5	2-3-6	1.2				STIFF 5YR 4/4 MODERATE BROWN CLAY 1.5 tsf, moist			
14	SS	19.5	21.0	4-5-6	0.9				STIFF 5YR 4/4 MODERATE BROWN CLAY			

TYPE OF CASING USED

<input checked="" type="checkbox"/>	NQ-2 ROCK CORE
<input checked="" type="checkbox"/>	6" x 3.25 HSA
	9" x 6.25 HSA
	HW CASING ADVANCER 4"
	NW CASING 3"
	SW CASING 6"
	AIR HAMMER 8"

Continued Next Page

PIEZOMETER TYPE: PT = OPEN TUBE POROUS TIP, SS = OPEN TUBE SLOTTED SCREEN, G = GEONOR, P = PNEUMATIC
 WELL TYPE: OW = OPEN TUBE SLOTTED SCREEN, GM = GEOMON

RECORDER **MCR / CB**

AMERICAN ELECTRIC POWER SERVICE CORPORATION
AEP CIVIL ENGINEERING LABORATORY
 LOG OF BORING



JOB NUMBER _____

COMPANY **APPALACHIAN POWER COMPANY**

BORING NO. **B0502** DATE **7/23/15** SHEET **2** OF **11**

PROJECT **MOUNTAINEER LBR LANDFILL**

BORING START **1/4/05** BORING FINISH **6/23/05**

SAMPLE NUMBER	SAMPLE	SAMPLE DEPTH IN FEET		STANDARD PENETRATION RESISTANCE BLOWS / 6"	TOTAL LENGTH RECOVERY	RQD	DEPTH IN FEET	GRAPHIC LOG	USCS	SOIL / ROCK IDENTIFICATION	WELL	DRILLER'S NOTES
		FROM	TO			%						
										1.75 tsf, moist		
15	SS	21.0	22.5	4-5-7	1.2					STIFF 5GY 4/1 DARK GREENISH GRAY CLAY 1.5 tsf, moist		
16	SS	22.5	24.0	2-5-7	1.2					STIFF 5GY 4/1 DARK GREENISH GRAY CLAY 1.5 tsf, w/ trace of fine sand, moist		
17	SS	24.0	25.5	1-3-4	1.3		25			MEDIUM STIFF 10YR 6/6 DARK YELLOWISH ORANGE CLAY 2.25 tsf, w/ some shale fragments, moist		
18	SS	25.5	27.0	3-5-12	1.2					VERY STIFF 10G 6/2 PALE GREEN SHALEY CLAY 2.0 tsf, moist		
19	SS	27.0	27.3	50/3	0.2					HARD 10G 6/2 PALE GREEN SHALEY CLAY Moist		
20	SS	28.5	28.9	50/4	0.5							
21	NQ2	29.5	35.7		5.3	100	30			5B 5/1 MEDIUM BLuish GRAY CLAY SHALE Soft broken area from 37.0' to 37.4'		Auger refusal @ 29.5'; started coring.
							35					
22	NQ2	35.7	45.7		9.3	90						
							40			5R 4/2 GRAYISH RED CLAY SHALE		
							45					

AEP MT LBR LF FKA SI/GPJ AEP.GDT 7/23/15

Continued Next Page

AMERICAN ELECTRIC POWER SERVICE CORPORATION
AEP CIVIL ENGINEERING LABORATORY
 LOG OF BORING



JOB NUMBER _____

COMPANY **APPALACHIAN POWER COMPANY**

BORING NO. **B0502** DATE **7/23/15** SHEET **3** OF **11**

PROJECT **MOUNTAINEER LBR LANDFILL**

BORING START **1/4/05** BORING FINISH **6/23/05**

SAMPLE NUMBER	SAMPLE	SAMPLE DEPTH IN FEET		STANDARD PENETRATION RESISTANCE BLOWS / 6"	TOTAL LENGTH RECOVERY	RQD	DEPTH IN FEET	GRAPHIC LOG	USCS	SOIL / ROCK IDENTIFICATION	WELL	DRILLER'S NOTES
		FROM	TO			%						
23	NQ2	45.7	55.7		4.4	30	50					Reason for poor recovery - Core lifter stuck in end of inner tube and washed core away
24	NQ2	55.7	65.7		9.8	87	55					
							60			5B 5/1 MEDIUM BLUISH GRAY CLAY SHALE		
25	NQ2	65.7	75.7		10.0	100	65					
							70			5B 7/1 LIGHT BLUISH GRAY FINE to MEDIUM GRAIN SANDSTONE		

AEP MT LBR LF FKA SI/GPJ AEP.GDT 7/23/15

Continued Next Page

AMERICAN ELECTRIC POWER SERVICE CORPORATION
AEP CIVIL ENGINEERING LABORATORY
 LOG OF BORING



JOB NUMBER _____

COMPANY **APPALACHIAN POWER COMPANY**

BORING NO. **B0502** DATE **7/23/15** SHEET **4** OF **11**

PROJECT **MOUNTAINEER LBR LANDFILL**

BORING START **1/4/05** BORING FINISH **6/23/05**

SAMPLE NUMBER	SAMPLE	SAMPLE DEPTH IN FEET		STANDARD PENETRATION RESISTANCE BLOWS / 6"	TOTAL LENGTH RECOVERY	RQD	DEPTH IN FEET	GRAPHIC LOG	USCS	SOIL / ROCK IDENTIFICATION	WELL	DRILLER'S NOTES
		FROM	TO			%						
26	NQ2	75.7	85.7		10.0	100	75					
27	NQ2	85.7	95.7		10.0	100	85					
28	NQ2	95.7	105.7		10.0	91	95			5B 5/1 MEDIUM BLUISH GRAY CLAY SHALE Area w/ numerous calcite deposits @ 92-93.6' 5B 7/1 LIGHT BLUISH GRAY FINE to MEDIUM GRAIN SANDSTONE		

AEP_Mt.LBR.LF.FKA.SJ.GPJ_AEP.GDT_7/23/15

Continued Next Page

AMERICAN ELECTRIC POWER SERVICE CORPORATION
AEP CIVIL ENGINEERING LABORATORY
 LOG OF BORING



JOB NUMBER _____

COMPANY **APPALACHIAN POWER COMPANY**

BORING NO. **B0502** DATE **7/23/15** SHEET **5** OF **11**

PROJECT **MOUNTAINEER LBR LANDFILL**

BORING START **1/4/05** BORING FINISH **6/23/05**

SAMPLE NUMBER	SAMPLE	SAMPLE DEPTH IN FEET		STANDARD PENETRATION RESISTANCE BLOWS / 6"	TOTAL LENGTH RECOVERY	RQD	DEPTH IN FEET	GRAPHIC LOG	USCS	SOIL / ROCK IDENTIFICATION	WELL	DRILLER'S NOTES
		FROM	TO			%						
							100					
29	NQ2	105.7	115.7		10.0	100	105			5B 5/1 MEDIUM BLUISH GRAY CLAY SHALE		
										5B 7/1 LIGHT BLUISH GRAY FINE to MEDIUM GRAIN SANDSTONE		
							110					
30	NQ2	115.7	125.7		10.0	100	115			5B 7/1 LIGHT BLUISH GRAY COARSE GRAIN SANDSTONE w/ cross bedding throughout		
							120					

AEP MT LBR LF FKA SI/GPJ AEP.GDT 7/23/15

Continued Next Page

AMERICAN ELECTRIC POWER SERVICE CORPORATION
AEP CIVIL ENGINEERING LABORATORY
 LOG OF BORING



JOB NUMBER _____

COMPANY **APPALACHIAN POWER COMPANY**

BORING NO. **B0502** DATE **7/23/15** SHEET **6** OF **11**

PROJECT **MOUNTAINEER LBR LANDFILL**

BORING START **1/4/05** BORING FINISH **6/23/05**

SAMPLE NUMBER	SAMPLE	SAMPLE DEPTH IN FEET		STANDARD PENETRATION RESISTANCE BLOWS / 6"	TOTAL LENGTH RECOVERY	RQD	DEPTH IN FEET	GRAPHIC LOG	USCS	SOIL / ROCK IDENTIFICATION	WELL	DRILLER'S NOTES
		FROM	TO			%						
31	NQ2	125.7	135.7		10.0	85	125					
							130					
32	NQ2	135.7	145.7		10.0	97	135					
							140					
										High angle fracture @ 142.2' w/ clay shale		
33	NQ2	145.7	155.7		10.0	83	145					

AEP_Mt.LBR.LF.FKA.SI.GPJ_AEP.GDT_7/23/15

Continued Next Page

AMERICAN ELECTRIC POWER SERVICE CORPORATION
AEP CIVIL ENGINEERING LABORATORY
 LOG OF BORING



JOB NUMBER _____

COMPANY **APPALACHIAN POWER COMPANY**

BORING NO. **B0502** DATE **7/23/15** SHEET **7** OF **11**

PROJECT **MOUNTAINEER LBR LANDFILL**

BORING START **1/4/05** BORING FINISH **6/23/05**

SAMPLE NUMBER	SAMPLE	SAMPLE DEPTH IN FEET		STANDARD PENETRATION RESISTANCE BLOWS / 6"	TOTAL LENGTH RECOVERY	RQD	DEPTH IN FEET	GRAPHIC LOG	USCS	SOIL / ROCK IDENTIFICATION	WELL	DRILLER'S NOTES
		FROM	TO			%						
							155			COAL		
34	NQ2	155.7	165.7		10.0	100				N4 MEDIUM DARK GRAY CLAY SHALE		
							160					
							165					
35	NQ2	165.7	175.7		10.0	84				5B 5/1 MEDIUM BLUISH GRAY CLAY SHALE		
							170					
							175					

AEP_Mt.LBR.LF.FKA.SI.GPJ_AEP.GDT_7/23/15

Continued Next Page

AMERICAN ELECTRIC POWER SERVICE CORPORATION
AEP CIVIL ENGINEERING LABORATORY
 LOG OF BORING



JOB NUMBER _____

COMPANY **APPALACHIAN POWER COMPANY**

BORING NO. **B0502** DATE **7/23/15** SHEET **8** OF **11**

PROJECT **MOUNTAINEER LBR LANDFILL**

BORING START **1/4/05** BORING FINISH **6/23/05**

SAMPLE NUMBER	SAMPLE	SAMPLE DEPTH IN FEET		STANDARD PENETRATION RESISTANCE BLOWS / 6"	TOTAL LENGTH RECOVERY	RQD	DEPTH IN FEET	GRAPHIC LOG	USCS	SOIL / ROCK IDENTIFICATION	WELL	DRILLER'S NOTES
		FROM	TO			%						
36	NQ2	175.7	183.2		7.5	91				5G 4/1 DARK GREENISH GRAY CLAY SHALE		
37	NQ2	183.2	185.2		2.2	64	180			5B 5/1 MEDIUM BLUISH GRAY CLAY SHALE Fracture @ 184.2'		Flushed boring with approx. 1000 gallons of water when boring stopped @ 183.2' on 1/12/05.
38	NQ2	185.2	191.2		3.9	85	185			Fracture @ 189.7'		SWL @ 8.8' on 6/22/05 with NQ hole to 183.2' Hole open to 175' Deconned rig & tools on 6/21/05 with water and liqui-nox. Resumed drilling on 6/22/05
39	NQ2	191.2	200.2		9.2	78	190			Soft area @ 196.1' to 196.9'		Picked up 0.2' of core from previous run.
40	NQ2	200.2	210.2		9.8	76	195			5B 5/1 MEDIUM BLUISH GRAY CLAY SHALE w/ 5R 4/2 GRAYISH RED LENSES		

AEP MT LBR LF FKA SI/GPJ AEP.GDT 7/23/15

Continued Next Page

AMERICAN ELECTRIC POWER SERVICE CORPORATION
AEP CIVIL ENGINEERING LABORATORY
 LOG OF BORING



JOB NUMBER _____

COMPANY **APPALACHIAN POWER COMPANY**

BORING NO. **B0502** DATE **7/23/15** SHEET **9** OF **11**

PROJECT **MOUNTAINEER LBR LANDFILL**

BORING START **1/4/05** BORING FINISH **6/23/05**

SAMPLE NUMBER	SAMPLE	SAMPLE DEPTH IN FEET		STANDARD PENETRATION RESISTANCE BLOWS / 6"	TOTAL LENGTH RECOVERY	RQD	DEPTH IN FEET	GRAPHIC LOG	USCS	SOIL / ROCK IDENTIFICATION	WELL	DRILLER'S NOTES
		FROM	TO			%						
							205			Fracture @ 203.1'		
							210			5B 5/1 MEDIUM BLUISH GRAY SILTY CLAY SHALE Hard		
41	NQ2	210.2	220.2		10	96	215			5B 5/1 MEDIUM BLUISH GRAY SILTY FINE GRAIN SANDSTONE		
							220			Soft area @ 224.3'		
42	NQ2	220.2	230.2		9.7	93	225			5B 5/1 MEDIUM BLUISH GRAY CLAY SHALE Hard		

AEP_Mt.LBR.LF.FKA.SI.GPJ.AEP.GDT.7/23/15

Continued Next Page

AMERICAN ELECTRIC POWER SERVICE CORPORATION
AEP CIVIL ENGINEERING LABORATORY
 LOG OF BORING



JOB NUMBER _____

COMPANY **APPALACHIAN POWER COMPANY**

BORING NO. **B0502** DATE **7/23/15** SHEET **10** OF **11**

PROJECT **MOUNTAINEER LBR LANDFILL**

BORING START **1/4/05** BORING FINISH **6/23/05**

SAMPLE NUMBER	SAMPLE	SAMPLE DEPTH IN FEET		STANDARD PENETRATION RESISTANCE BLOWS / 6"	TOTAL LENGTH RECOVERY	RQD	DEPTH IN FEET	GRAPHIC LOG	USCS	SOIL / ROCK IDENTIFICATION	WELL	DRILLER'S NOTES
		FROM	TO			%						
43	NQ2	230.2	240.2		10.1	70	230			5B 5/1 MEDIUM BLUISH GRAY SILTY CLAY SHALE Hard Soft area @ 232.0'		Picked up 0.1' of core from previous run.
							235			5B 5/1 MEDIUM BLUISH GRAY CLAY SHALE Hard 5B 7/1 LIGHT BLUISH GRAY MEDIUM GRAIN SANDSTONE w/ COAL STREAKS THROUGHOUT		
44	NQ2	240.2	250.2		9.9	96	240			5B 7/1 LIGHT BLUISH GRAY MEDIUM GRAIN SANDSTONE w/ COAL STREAKS THROUGHOUT		
							245			CLAY SHALE AREA @ 248.3 - 248.4' 5B 7/1 LIGHT BLUISH GRAY MEDIUM GRAIN SANDSTONE w/ COAL STREAKS THROUGHOUT		
							250					Stopped boring @ 250.2' on 6/23/05. Flushed boring with approx. 700 gallons of water. Boring was geo-physical logged on 6/29/05. Installation of 1" geomon well

AEP MT LBR LF FKA SJ/GPJ AEP.GDT 7/23/15

Continued Next Page

AMERICAN ELECTRIC POWER SERVICE CORPORATION
AEP CIVIL ENGINEERING LABORATORY
 LOG OF BORING



JOB NUMBER _____

COMPANY **APPALACHIAN POWER COMPANY**

BORING NO. **B0502** DATE **7/23/15** SHEET **11** OF **11**

PROJECT **MOUNTAINEER LBR LANDFILL**

BORING START **1/4/05** BORING FINISH **6/23/05**

SAMPLE NUMBER	SAMPLE	SAMPLE DEPTH IN FEET		STANDARD PENETRATION RESISTANCE BLOWS / 6"	TOTAL LENGTH RECOVERY	RQD	DEPTH IN FEET	GRAPHIC LOG	USCS	SOIL / ROCK IDENTIFICATION	WELL	DRILLER'S NOTES
		FROM	TO			%						
												(MW-42) will be done at a later date.



AEP 2010, 2012

Boring Logs

B-0901 to B-0903, B-1201

AMERICAN ELECTRIC POWER SERVICE CORPORATION
AEP CIVIL ENGINEERING LABORATORY
 LOG OF BORING



JOB NUMBER _____
 COMPANY **APPALACHIAN POWER COMPANY**
 PROJECT **MOUNTAINEER LBR LANDFILL**
 COORDINATES **N 708,953.7 E 1,729,008.3**
 GROUND ELEVATION **852.2** SYSTEM State Plane using NAD27/29

BORING NO. **B-0901** DATE **7/23/15** SHEET **1** OF **7**
 BORING START **1/5/10** BORING FINISH **1/7/10**
 PIEZOMETER TYPE **N/A** WELL TYPE **OW**
 HGT. RISER ABOVE GROUND **2.60** DIA **2.0**
 DEPTH TO TOP OF WELL SCREEN **98.1** BOTTOM **133.1**
 WELL DEVELOPMENT **YES** BACKFILL **QUICK GROUT**
 FIELD PARTY **ZLR / MWJ** RIG **D-120**

Water Level, ft	<input type="checkbox"/>	<input type="checkbox"/>	<input type="checkbox"/>
TIME			
DATE			

SAMPLE NUMBER	SAMPLE	SAMPLE DEPTH IN FEET		STANDARD PENETRATION RESISTANCE BLOWS / 6"	TOTAL LENGTH RECOVERY	RQD %	DEPTH IN FEET	GRAPHIC LOG	USCS	SOIL / ROCK IDENTIFICATION	WELL	DRILLER'S NOTES
		FROM	TO									
							5			GROUNDING PROCEDURE NOT IN USE / DOZED A PAD ~1' OF FILL / CORE RUNNING DOWN 4" CASING TO 8.9' / WATER FROM MT FIRE SYSTEM / DECONEED 8:30 01/05/10		
1	NQ	8.9	14.6		1.6		10			LIGHT BROWN 5YR 5/6 SANDSTONE		
2	NQ	14.6	24.6		9.4	64	15			LIGHT BROWN 5YR 5/6 HARD FINE SANDSTONE		
										MODERATE YELLOWISH BROWN 10YR 5/4 HARD FINE GRAIN SANDSTONE		
										MEDIUM BLUISH GRAY 5B 5/1 HARD FINE GRAIN SANDSTONE W/CLAYSHALE		

TYPE OF CASING USED

Continued Next Page

X	NQ-2 ROCK CORE
	6" x 3.25 HSA
	9" x 6.25 HSA
	HW CASING ADVANCER 4"
	NW CASING 3"
	SW CASING 6"
	AIR HAMMER 8"

PIEZOMETER TYPE: PT = OPEN TUBE POROUS TIP, SS = OPEN TUBE SLOTTED SCREEN, G = GEONOR, P = PNEUMATIC
 WELL TYPE: OW = OPEN TUBE SLOTTED SCREEN, GM = GEOMON

RECORDER _____

AMERICAN ELECTRIC POWER SERVICE CORPORATION
AEP CIVIL ENGINEERING LABORATORY
 LOG OF BORING



JOB NUMBER _____

COMPANY **APPALACHIAN POWER COMPANY**

BORING NO. **B-0901** DATE **7/23/15** SHEET **2** OF **7**

PROJECT **MOUNTAINEER LBR LANDFILL**

BORING START **1/5/10** BORING FINISH **1/7/10**

SAMPLE NUMBER	SAMPLE	SAMPLE DEPTH IN FEET		STANDARD PENETRATION RESISTANCE BLOWS / 6"	TOTAL LENGTH RECOVERY	RQD	DEPTH IN FEET	GRAPHIC LOG	USCS	SOIL / ROCK IDENTIFICATION	WELL	DRILLER'S NOTES
		FROM	TO			%						
3	NQ	24.6	34.6		8.8	17	25			MEDIUM GRAY N5 HARD COARSE SANDSTONE w/fractures MEDIUM GRAY N5 COARSE SANDSTONE w/crossbeddings throughout		
							30			BROWNISH GRAY 5YR 4/1 HARD COARSE SANDSTONE w/fractures MEDIUM GRAY N5 HARD COARSE SANDSTONE w/crossbeddings throughout		
4	NQ	34.6	44.6		3.9	100	35			MEDIUM LIGHT GRAY N6 SOFT SILTY CLAYSHALE DUSKY RED 5R 3/4 SOFT CLAYSHALE		
							40			MEDIUM BLUISH GRAY 5B 5/1 HARD CLAYSHALE		
5	NQ	44.6	54.6		10.0	60	45			MEDIUM BLUISH GRAY 5B 5/1 CLAYSHALE		

AEP MT LBR LF FKA SI/GPJ AEP.GDT 7/23/15

Continued Next Page

AMERICAN ELECTRIC POWER SERVICE CORPORATION
AEP CIVIL ENGINEERING LABORATORY
 LOG OF BORING



JOB NUMBER _____

COMPANY **APPALACHIAN POWER COMPANY**

BORING NO. **B-0901** DATE **7/23/15** SHEET **3** OF **7**

PROJECT **MOUNTAINEER LBR LANDFILL**

BORING START **1/5/10** BORING FINISH **1/7/10**

SAMPLE NUMBER	SAMPLE	SAMPLE DEPTH IN FEET		STANDARD PENETRATION RESISTANCE BLOWS / 6"	TOTAL LENGTH RECOVERY	RQD	DEPTH IN FEET	GRAPHIC LOG	USCS	SOIL / ROCK IDENTIFICATION	WELL	DRILLER'S NOTES
		FROM	TO			%						
							50			MEDIUM BLuish GRAY 5B 5/1 SOFT CLAYSHALE		
										MEDIUM BLuish GRAY 5B 5/1 HARD CLAYSHALE		
6	NQ	54.6	64.6		10.0		55			MEDIUM GRAY N5 SANDSTONE		
										MEDIUM GRAY N5 COARSE HARD SANDSTONE		
							60			MEDIUM DARK GRAY N4 SILTY HARD SHALE		
7	NQ	64.6	74.6		8.8		65			MEDIUM DARK GRAY N4 SHALE		
										GRAYISH RED 5R 4/2 HARD SHALE		
										MEDIUM GRAY N5 SOFT SHALE		
							70			DARK REDISH BROWN 10R 2/2 SOFT SILTY CLAYSHALE		

AEP MT LBR LF FKA SJG/PJ AEP.GDT 7/23/15

Continued Next Page

AMERICAN ELECTRIC POWER SERVICE CORPORATION
AEP CIVIL ENGINEERING LABORATORY
 LOG OF BORING



JOB NUMBER _____

COMPANY **APPALACHIAN POWER COMPANY**

BORING NO. **B-0901** DATE **7/23/15** SHEET **4** OF **7**

PROJECT **MOUNTAINEER LBR LANDFILL**

BORING START **1/5/10** BORING FINISH **1/7/10**

SAMPLE NUMBER	SAMPLE	SAMPLE DEPTH IN FEET		STANDARD PENETRATION RESISTANCE BLOWS / 6"	TOTAL LENGTH RECOVERY	RQD	DEPTH IN FEET	GRAPHIC LOG	USCS	SOIL / ROCK IDENTIFICATION	WELL	DRILLER'S NOTES
		FROM	TO			%						
8	NQ	74.6	84.6		10.0	48	75			VERY DARK RED 5R 2/6 SOFT SHALE		
										MODERATE BLUISH GRAY 5B 5/1 HARD SHALE		
							80			VERY DARK RED 5R 2/6 SOFT SHALE		
										MODERATE BLUISH GRAY 5B 5/1 HARD SHALE		
9	NQ	84.6	94.6		9.7	47	85			DARK GREENISH GRAY 5G 4/1 HARD SHALE		
										DARK REDISH BROWN 10YR 3/4 SOFT SHALE		
										DARK GREENISH GRAY 5G 4/1 HARD SHALE		
							90					
10	NQ	94.6	104.6		10.0	63	95			DARK GREENISH GRAY 5G 4/1 HARD SHALE		

AEP MT LBR LF FKA SI/GPJ AEP.GDT 7/23/15

Continued Next Page

AMERICAN ELECTRIC POWER SERVICE CORPORATION
AEP CIVIL ENGINEERING LABORATORY
 LOG OF BORING



JOB NUMBER _____

COMPANY **APPALACHIAN POWER COMPANY**

BORING NO. **B-0901** DATE **7/23/15** SHEET **5** OF **7**

PROJECT **MOUNTAINEER LBR LANDFILL**

BORING START **1/5/10** BORING FINISH **1/7/10**

SAMPLE NUMBER	SAMPLE	SAMPLE DEPTH IN FEET		STANDARD PENETRATION RESISTANCE BLOWS / 6"	TOTAL LENGTH RECOVERY	RQD	DEPTH IN FEET	GRAPHIC LOG	USCS	SOIL / ROCK IDENTIFICATION	WELL	DRILLER'S NOTES
		FROM	TO			%						
							100					
11	NQ	104.6	114.6		10.0	70	105			MEDIUM GRAY N5 COARSE HARD SANDSTONE w/crossbeddings throughout		
							110			MEDIUM GRAY N5 COARSE HARD SANDSTONE w/crossbedding throughout		
							115			MEDIUM DARK GRAY N4 SOFT SHALE		
										GRAYISH RED 10R 4/2 SOFT SILTY CLAYSHALES		
12	NQ	114.6	124.6		9.6	96	115			DARK GREENISH GRAY 5G 4/1 HARD SHALE		
										DARK GREENISH GRAY 5G 4/1 HARD SHALE w/fine sandstone		
							120			GRAYISH RED 5R 4/2 HARD SHALE		
										DARK GREENISH GRAY 5G 4/1 HARD SHALE		

AEP MT LBR LF FKA SJ/GPJ AEP.GDT 7/23/15

Continued Next Page

AMERICAN ELECTRIC POWER SERVICE CORPORATION
AEP CIVIL ENGINEERING LABORATORY
 LOG OF BORING



JOB NUMBER _____

COMPANY **APPALACHIAN POWER COMPANY**

BORING NO. **B-0901** DATE **7/23/15** SHEET **6** OF **7**

PROJECT **MOUNTAINEER LBR LANDFILL**

BORING START **1/5/10** BORING FINISH **1/7/10**

SAMPLE NUMBER	SAMPLE	SAMPLE DEPTH IN FEET		STANDARD PENETRATION RESISTANCE BLOWS / 6"	TOTAL LENGTH RECOVERY	RQD	DEPTH IN FEET	GRAPHIC LOG	USCS	SOIL / ROCK IDENTIFICATION	WELL	DRILLER'S NOTES
		FROM	TO			%						
13	NQ	124.6	134.6		10.0	96	125			MEDIUM BLUISH GRAY 5B 5/1 HARD SHALE		
							130			BROWNISH GRAY 5YR 4/1 HARD SHALE		
										BROWNISH GRAY 5YR 4/1 HARD SHALE w/fine grain sandstone		
14	NQ	134.6	144.6		10.0	76	135			MEDIUM DARK GRAY N4 HARD SHALE		
										GRAYISH RED 5R 4/2 HARD SHALE		
										MEDIUM GRAY N5 HARD LIMESTONE		
							140			GRAYISH RED 5R 4/2 SOFT SHALE		
15	NQ	144.6	154.6		10.0	56	145			DARK REDDISH BROWN 10R 3/4 SOFT CLAYSHALE 145.0' - 146.8 and 147.8' - 151.0' fractures throughout		

AEP_Mt.LBR.LF.FKA.SI.GPJ_AEP.GDT_7/23/15

Continued Next Page

AMERICAN ELECTRIC POWER SERVICE CORPORATION
AEP CIVIL ENGINEERING LABORATORY
 LOG OF BORING



JOB NUMBER _____

COMPANY **APPALACHIAN POWER COMPANY**

BORING NO. **B-0901** DATE **7/23/15** SHEET **7** OF **7**

PROJECT **MOUNTAINEER LBR LANDFILL**

BORING START **1/5/10** BORING FINISH **1/7/10**

SAMPLE NUMBER	SAMPLE	SAMPLE DEPTH IN FEET		STANDARD PENETRATION RESISTANCE BLOWS / 6"	TOTAL LENGTH RECOVERY	RQD	DEPTH IN FEET	GRAPHIC LOG	USCS	SOIL / ROCK IDENTIFICATION	WELL	DRILLER'S NOTES
		FROM	TO			%						
16	NQ	154.6	159.6		4.9	73	155			<p>BROWNISH GRAY 5YR 4/1 HARD CLAYSHALE w/limestone nodules throughout</p> <p>MEDIUM GRAY N4 HARD SHALE w/limestone nodules</p> <p>MEDIUM GRAY N4 SOFT SHALE w/limestone nodules</p> <p>BROWNISH GRAY 5YR 4/1 HARD LIMESTONE w/some hard clayshale</p>		<p>STOPPED BORING @ 159.6' / PACKER TESTED BOREHOLE / BENTONITE PELLETS FROM 159.6' - 137.0' / PULLED 4" CASING / DECONNED 01/14/10 / DRILLED 6" CASING TO 9.5' / AIR HAMMER TO 136.0'</p>

AMERICAN ELECTRIC POWER SERVICE CORPORATION
AEP CIVIL ENGINEERING LABORATORY
 LOG OF BORING



JOB NUMBER _____
 COMPANY **APPALACHIAN POWER COMPANY**
 PROJECT **MOUNTAINEER LBR LANDFILL**
 COORDINATES **N 709,192.0 E 1,728,205.5**
 GROUND ELEVATION **808.8** SYSTEM State Plane using NAD27/29

BORING NO. **B-0902** DATE **7/23/15** SHEET **1** OF **2**
 BORING START **1/19/10** BORING FINISH **1/19/10**
 PIEZOMETER TYPE **N/A** WELL TYPE **OW**
 HGT. RISER ABOVE GROUND **3.04** DIA **2.0**
 DEPTH TO TOP OF WELL SCREEN **55.6** BOTTOM **80.4**
 WELL DEVELOPMENT **YES** BACKFILL **QUICK GROUT**
 FIELD PARTY **ZLR / MWJ** RIG **D-120**

Water Level, ft	<input type="checkbox"/>	<input type="checkbox"/>	<input type="checkbox"/>
TIME			
DATE			

SAMPLE NUMBER	SAMPLE	SAMPLE DEPTH IN FEET		STANDARD PENETRATION RESISTANCE BLOWS / 6"	TOTAL LENGTH RECOVERY	RQD %	DEPTH IN FEET	GRAPHIC LOG	USCS	SOIL / ROCK IDENTIFICATION	WELL	DRILLER'S NOTES
		FROM	TO									
1	SPT	0.0	2.0	3-4-10-19	1.6					VERY STIFF MEDIUM DARK GRAY N4 FLYASH moist		
2	SPT	2.0	4.0	3-6-14-22	2.0					HARD MEDIUM GRAY N5 FLYASH moist		
3	SPT	4.0	6.0	3-2-8-17	2.0					VERY STIFF MEDIUM GRAY N5 FLYASH moist		
4	SPT	6.0	8.0	4-2-9-15	2.0		5			VERY STIFF N4 FLYASH moist		
5	SPT	8.0	10.0	4-7-13-27	2.0					HARD MEDIUM LIGHT GRAY N6 FLYASH moist		
6	SPT	10.0	12.0	2-4-10-25	2.0		10			HARD MEDIUM DARK GRAY N4 FLYASH moist		
7	SPT	12.0	14.0	1-5-7-13	1.6					VERY STIFF MEDIUM DARK GRAY N4 FLYASH 1.0 tsf, moist, wet		
8	SPT	14.0	16.0	1-6-8-13	1.8					VERY STIFF N4 MEDIUM DARK GRAY FLYASH 1.5 tsf, moist, wet		
9	SPT	16.0	18.0	2-3-4-6	1.4		15			MEDIUM STIFF N4 MEDIUM DARK GRAY FLYASH 2.5 tsf, moist/wet, trace of clay in end of spoon		
10	SPT	18.0	20.0	2-2-6-12	1.5					VERY STIFF LIGHT BROWN 5YR 5/6 STIFF CLAY 2.25 tsf, w/some fine sand, moist		

TYPE OF CASING USED

<input checked="" type="checkbox"/>	NQ-2 ROCK CORE
<input checked="" type="checkbox"/>	6" x 3.25 HSA
	9" x 6.25 HSA
	HW CASING ADVANCER 4"
	NW CASING 3"
	SW CASING 6"
	AIR HAMMER 8"

Continued Next Page

PIEZOMETER TYPE: PT = OPEN TUBE POROUS TIP, SS = OPEN TUBE SLOTTED SCREEN, G = GEONOR, P = PNEUMATIC
 WELL TYPE: OW = OPEN TUBE SLOTTED SCREEN, GM = GEOMON

RECORDER _____

AEP_Mt.LBR.LF.FKA.SI.GPJ.AEP.GDT.7/23/15

AMERICAN ELECTRIC POWER SERVICE CORPORATION
AEP CIVIL ENGINEERING LABORATORY
 LOG OF BORING



JOB NUMBER _____

COMPANY **APPALACHIAN POWER COMPANY**

BORING NO. **B-0902** DATE **7/23/15** SHEET **2** OF **2**

PROJECT **MOUNTAINEER LBR LANDFILL**

BORING START **1/19/10** BORING FINISH **1/19/10**

SAMPLE NUMBER	SAMPLE	SAMPLE DEPTH IN FEET		STANDARD PENETRATION RESISTANCE BLOWS / 6"	TOTAL LENGTH RECOVERY	RQD	DEPTH IN FEET	GRAPHIC LOG	USCS	SOIL / ROCK IDENTIFICATION	WELL	DRILLER'S NOTES
		FROM	TO			%						
11	SPT	20.0	22.0	2-10-19-30	1.8					HARD LIGHT BROWN 5YR 5/6 HARD CLAY w/trace of fine sand, dry		
12	SPT	22.0	24.0	7-11-15-27	2.0					HARD LIGHT BROWN 5YR 5/6 SILTY CLAY 3.5 tsf, w/trace of weathered sandstone fragments, dry		
13	SPT	24.0	26.0	4-11-19-30	2.0		25			HARD LIGHT BROWN 5YR 5/6 SILTY CLAY 3.0 tsf, w/trace of weathered sandstone fragments, dry		
14	SPT	26.0	28.0	6-8-10-22	1.8					VERY STIFF LIGHT BROWN 5YR 5/6 SILTY CLAY 3.5 tsf, w/trace of weathered sandstone fragments, moist		
15	SPT	28.0	30.0	3-8-12-31	1.2					VERY STIFF DARK REDDISH BROWN 10R 3/4 CLAY 2.5 tsf, moist		
16	SPT	30.0	30.6	35-50/1	.6		30			HARD DRAK REDDISH BROWN 10R 3/4 CLAY dry		
										HARD DRAK REDDISH BROWN 10R 3/4 WEATHERED CLAYSHALE 3.5 tsf, dry		
										HARD PALE YELLOWISH BROWN 10YR 6/2 CLAYSHALE dry		
										SPOON REFUSAL @ 30.6' / FINISHED SPLIT SPOONING 01/19/10 / NOTICED ALOT OF RUST/IRON IN DRILL & DECON WATER / DRILLED 6" ROLLER BIT W/WATER TO 30.0' / PLACED 3/8" HOLE PLUG FROM 30.0' TO 26.5' / PULLED 6.25" HSA'S AND INSERTED 6" SW CASING TO 30.' / CLEANED BENTONITE FROM INSIDE OF 6' SW CASING W/6" ROLLER BIT & WATER TO CORE / STARTED CORING @ 30.2'		

AMERICAN ELECTRIC POWER SERVICE CORPORATION
AEP CIVIL ENGINEERING LABORATORY
 LOG OF BORING



JOB NUMBER _____
 COMPANY **APPALACHIAN POWER COMPANY**
 PROJECT **MOUNTAINEER LBR LANDFILL**
 COORDINATES **N 710,168.6 E 1,728,017.3**
 GROUND ELEVATION **793.0** SYSTEM State Plane using NAD27/29

BORING NO. **B-0903** DATE **7/23/15** SHEET **1** OF **4**
 BORING START **2/2/10** BORING FINISH **2/2/10**
 PIEZOMETER TYPE **N/A** WELL TYPE **OW**
 HGT. RISER ABOVE GROUND **2.88** DIA **2.0**
 DEPTH TO TOP OF WELL SCREEN **59.6** BOTTOM **79.4**
 WELL DEVELOPMENT **YES** BACKFILL **QUICK GROUT**
 FIELD PARTY **ZLR / MWJ** RIG **D-120**

Water Level, ft	<input type="checkbox"/>	<input type="checkbox"/>	<input type="checkbox"/>
TIME			
DATE			

SAMPLE NUMBER	SAMPLE	SAMPLE DEPTH IN FEET		STANDARD PENETRATION RESISTANCE BLOWS / 6"	TOTAL LENGTH RECOVERY	RQD %	DEPTH IN FEET	GRAPHIC LOG	USCS	SOIL / ROCK IDENTIFICATION	WELL	DRILLER'S NOTES
		FROM	TO									
1	SPT	0.0	2.0	11-5-5-11	.7					VERY STIFF GRAYISH RED 5R 4/2 CLAY 4.5 tsf, dry		GROUNDING PROCEDURE NOT IN USE ON THIS BORING.
2	SPT	2.0	4.0	6-7-8-12	1.0					VERY STIFF GRAYISH RED 5R 4/2 CLAY 3.75 tsf, dry		
3	SPT	4.0	6.0	3-4-8-17	1.6					VERY STIFF LIGHT BROWNISH GRAY 5YR 6/1 CLAY dry		
							5			VERY STIFF MEDIUM GRAY N5 FLYASH 1.0 tsf, moist		
4	SPT	6.0	8.0	9-8-12-20	1.7					HARD LIGHT GRAY N6 FLYASH 1.75 tsf		
										MEDIUM DARK GRAY N4 FLYASH dry		
5	SPT	8.0	10.0	4-5-12-19	1.0					MEDIUM LIGHT GRAY N6 FLYASH 1.25 tsf		
							10			HARD LIGHT BROWN 5YR 5/6 SANDSTONE AND CLAY moist		
6	SPT	10.0	12.0	5-5-11-18	1.3					MEDIUM LIGHT GRAY N6 FLYASH 1.0 tsf, moist		
7	SPT	12.0	14.0	1-8-17-38	1.2					DARK REDDISH BROWN 10R 3/4 HARD CLAY w/little red gravels/sand, moist		
8	SPT	14.0	16.0	3-10-23-39	1.6					MEDIUM GRAY N5 FLYASH 1.5 tsf, moist		
							15			HARD MEDIUM GRAY N5 FLYASH 1.0 tsf, dry		
9	SPT	16.0	18.0	3-10-17-20	1.0					HARD MEDIUM GRAY N5 FLYASH 1.5 tsf, moist		
10	SPT	18.0	20.0	3-6-7-12	1.4					VERY STIFF MEDIUM GRAY N5 FLYASH .5 tsf, moist		

TYPE OF CASING USED

<input checked="" type="checkbox"/>	NQ-2 ROCK CORE
<input checked="" type="checkbox"/>	6" x 3.25 HSA
	9" x 6.25 HSA
	HW CASING ADVANCER 4"
	NW CASING 3"
	SW CASING 6"
	AIR HAMMER 8"

Continued Next Page

PIEZOMETER TYPE: PT = OPEN TUBE POROUS TIP, SS = OPEN TUBE SLOTTED SCREEN, G = GEONOR, P = PNEUMATIC
 WELL TYPE: OW = OPEN TUBE SLOTTED SCREEN, GM = GEOMON

RECORDER _____

AEP_Mt.LBR.LF.FKA.SI.GPJ.AEP.GDT.7/23/15

AMERICAN ELECTRIC POWER SERVICE CORPORATION
AEP CIVIL ENGINEERING LABORATORY
 LOG OF BORING



JOB NUMBER _____

COMPANY **APPALACHIAN POWER COMPANY**

BORING NO. **B-0903** DATE **7/23/15** SHEET **2** OF **4**

PROJECT **MOUNTAINEER LBR LANDFILL**

BORING START **2/2/10** BORING FINISH **2/2/10**

SAMPLE NUMBER	SAMPLE	SAMPLE DEPTH IN FEET		STANDARD PENETRATION RESISTANCE BLOWS / 6"	TOTAL LENGTH RECOVERY	RQD		DEPTH IN FEET	GRAPHIC LOG	USCS	SOIL / ROCK IDENTIFICATION	WELL	DRILLER'S NOTES
		FROM	TO			%							
11	SPT	20.0	22.0	3-3-6-7	1.6						STIFF MODERATE YELLOWISH BROWN 10YR 5/4 CLAY .75 tsf, moist		
12	SPT	22.0	24.0	4-4-12-20	1.7						HARD DARK YELLOWISH ORANGE 10YR 6/6 CLAY 3.0 tsf, moist		
13	SPT	24.0	26.0	5-7-10-17	1.9			25			VERY STIFF HARD DARK YELLOWISH ORANGE 10YR 6/6 CLAY 2.75 tsf, moist		
14	SPT	26.0	28.0	4-5-8-12	1.6						VERY STIFF HARD DARK YELLOWISH ORANGE 10YR 6/6 CLAY 3.0 tsf, moist		
15	SPT	28.0	30.0	3-3-4-7							STIFF YELLOWISH ORANGE 10YR 6/6 CLAY 1.0 tsf, moist		
16	SPT	30.0	32.0	4-6-9-13	1.4			30			VERY STIFF MODERATE YELLOWISH BROWN 10YR 5/4 CLAY .75 tsf, w/little sand, moist		
17	SPT	32.0	33.8	4-7-27-50/.3	1.6						HARD DARK YELLOWISH BROWN 10YR 5/4 CLAY 2.5 tsf, w/weathered sandstone, moist		
18	SPT	34.0	34.8	40-50/.3	.8								
1	NQ	35.0	39.0		2.5	0		35			DARK YELLOWISH ORANGE 10YR 6/6 SOFT CLAYSHALE		STOPPED SPLIT SPOONING @ 34.8' / PLACED 4.6' of SEAL IN BOTTOM OF BORING / PULLED AUGERS / DECONNED TOOLS ON 02/02/10 / SET 6" CASING TO 34.8' in 4.6' SEAL / WASHED PLUG OUT OF 6" CASING
2	NQ	39.0	49.0		10.0	18		40					
								45			MEDIUM LIGHT GRAY SHALE		
											MEDIUM LIGHT GRAY SHALE w/iron staining		
											MEDIUM GRAY N5 SHALE w/iron staining @ 45.6' and 47.1'		

AEP MT LBR LF FKA SI/GPJ AEP.GDT 7/23/15

Continued Next Page

AMERICAN ELECTRIC POWER SERVICE CORPORATION
AEP CIVIL ENGINEERING LABORATORY
 LOG OF BORING



JOB NUMBER _____

COMPANY **APPALACHIAN POWER COMPANY**

BORING NO. **B-0903** DATE **7/23/15** SHEET **3** OF **4**

PROJECT **MOUNTAINEER LBR LANDFILL**

BORING START **2/2/10** BORING FINISH **2/2/10**

SAMPLE NUMBER	SAMPLE	SAMPLE DEPTH IN FEET		STANDARD PENETRATION RESISTANCE BLOWS / 6"	TOTAL LENGTH RECOVERY	RQD	DEPTH IN FEET	GRAPHIC LOG	USCS	SOIL / ROCK IDENTIFICATION	WELL	DRILLER'S NOTES
		FROM	TO			%						
3	NQ	49.0	59.0		10.0	70	50			MEDIUM DARK GRAY N4 SOFT CLAYSHALE		
							55			MEDIUM BLuish GRAY 5B 5/1 HARD SANDY CLAYSHALE w/high angle fracture 58.3' to 59.0'		
4	NQ	59.0	69.0		10.0	56	60			MEDIUM BLuish GRAY 5B 5/1 CLAYSHALE		
							65			MEDIUM GRAY N5 WELL CEMENTED FINE GRAIN SANDSTONE		
										MEDIUM GRAY N5 HARD SHALE		
							70			BROWNISH GRAY 5YR 4/1 HARD SHALE		
5	NQ	69.0	79.0		10.0	64				BROWNISH GRAY 5YR 4/1 FINE GRAIN SANDSTONE		
										MEDIUM BLuish GRAY 5B 5/1 HARD FINE GRAIN SANDSTONE		
										BROWNISH GRAY 5YR 4/1 HARD SHALE		

AEP_Mt_LBR_LF_FKA_Si_GPJ_AEP.GDT_7/23/15

Continued Next Page

AMERICAN ELECTRIC POWER SERVICE CORPORATION
AEP CIVIL ENGINEERING LABORATORY
 LOG OF BORING



JOB NUMBER _____

COMPANY **APPALACHIAN POWER COMPANY**

BORING NO. **B-0903** DATE **7/23/15** SHEET **4** OF **4**

PROJECT **MOUNTAINEER LBR LANDFILL**

BORING START **2/2/10** BORING FINISH **2/2/10**

SAMPLE NUMBER	SAMPLE	SAMPLE DEPTH IN FEET		STANDARD PENETRATION RESISTANCE BLOWS / 6"	TOTAL LENGTH RECOVERY	RQD	DEPTH IN FEET	GRAPHIC LOG	USCS	SOIL / ROCK IDENTIFICATION	WELL	DRILLER'S NOTES
		FROM	TO			%						
6	NQ	79.0	85.8		5.4	33	75			MEDIUM GRAY N5 HARD FINE GRAIN SANDSTONE		
							80			MEDIUM GRAY N5 HARD FINE GRAIN SANDSTONE		
										MEDIUM LIGHT GRAY SOFT CLAYSHALE		
										DARK REDDISH BROWN SOFT CLAYSHALE		
							85					

AMERICAN ELECTRIC POWER SERVICE CORPORATION
AEP CIVIL ENGINEERING LABORATORY
 LOG OF BORING



JOB NUMBER _____
 COMPANY **APPALACHIAN POWER COMPANY**
 PROJECT **MOUNTAINEER LBR LANDFILL**
 COORDINATES **N 714,832.4 E 1,733,268.2**
 GROUND ELEVATION **621.6** SYSTEM State Plane using NAD27/29

BORING NO. **B-1201** DATE **7/23/15** SHEET **1** OF **2**
 BORING START **1/10/12** BORING FINISH **1/10/12**
 PIEZOMETER TYPE _____ WELL TYPE _____
 HGT. RISER ABOVE GROUND **2.132** DIA **2.0**
 DEPTH TO TOP OF WELL SCREEN **18.4** BOTTOM **28.0**
 WELL DEVELOPMENT **Yes** BACKFILL _____
 FIELD PARTY **ZLR** RIG **D-120**

Water Level, ft	<input type="checkbox"/>	<input type="checkbox"/>	<input type="checkbox"/>
TIME			
DATE			

SAMPLE NUMBER	SAMPLE	SAMPLE DEPTH IN FEET		STANDARD PENETRATION RESISTANCE BLOWS / 6"	TOTAL LENGTH RECOVERY	RQD %	DEPTH IN FEET	GRAPHIC LOG	USCS	SOIL / ROCK IDENTIFICATION	WELL	DRILLER'S NOTES
		FROM	TO									
1	SPT	0.0	1.5	4-2-4	.2					GRAVEL ROAD BASE		Grounding procedures in use. Drilling w/ 3.25" augers and split spoon sampling. Used high pressure and steam cleaning at plant.
2	SPT	1.5	3.0	4-2-4	.2					MEDIUM STIFF MODERATE BROWN 5YR 4/4 CLAY		
3	SPT	3.0	4.5	2-4-5	.53					SOFT MODERATE BROWN 5YR 3/4 CLAY		
4	SPT	4.5	6.0	2-1-1	1.3		5			SOFT MODERATE BROWN 5YR 4/4 CLAY .5 tsf		
5	SPT	6.0	7.5	4-3-3	1.1					SOFT DUSKY BROWN 5YR 2/2 CLAY .5 tsf		
6	SPT	7.5	9.0	4-5-6	.54					MEDIUM STIFF PALE BROWN 5YR 5/2 CLAY 1.0 tsf		
7	SPT	9.0	10.5	3-4-9	1.5					STIFF GRAYISH BROWN 5YR 3/2 CLAY		
8	SPT	10.5	12.0	3-4-4	1.5		10			STIFF LIGHT BROWN 5YR 5/6 CLAY 2.0 tsf		
9	SPT	12.0	13.5	2-3-2	1.5					STIFF LIGHT BROWN 5YR 5/6 CLAY .5 tsf		
10	SPT	13.5	15.0	5-7-15	1.5					MEDIUM STIFF LIGHT BROWN 5YR 5/6 CLAY .5 tsf		
11	SPT	15.0	16.5	3-4-7	1.5		15			VERY STIFF MODERATE BROWN 5YR 4/4 CLAY 3.0 tsf		
12	SPT	16.5	18.0	3-3-4	1.5					STIFF PALE BROWN 5YR 5/2 CLAY 2.5 tsf, wet		
13	SPT	18.0	19.5	3-3-14	1.4					MEDIUM STIFF MEDIUM LIGHT GRAY N6 CLAY 1.0 tsf, moist		
14	SPT	19.5	21.0	3-3-4	1.2					VERY STIFF MEDIUM GRAY N5 CLAY 1.0 tsf, wet		
										MEDIUM STIFF MEDIUM LIGHT GRAY N6		

TYPE OF CASING USED

<input type="checkbox"/>	NQ-2 ROCK CORE	
<input checked="" type="checkbox"/>	6" x 3.25 HSA	
<input type="checkbox"/>	9" x 6.25 HSA	
<input type="checkbox"/>	HW CASING ADVANCER	4"
<input type="checkbox"/>	NW CASING	3"
<input type="checkbox"/>	SW CASING	6"
<input type="checkbox"/>	AIR HAMMER	8"

Continued Next Page

PIEZOMETER TYPE: PT = OPEN TUBE POROUS TIP, SS = OPEN TUBE SLOTTED SCREEN, G = GEONOR, P = PNEUMATIC
 WELL TYPE: OW = OPEN TUBE SLOTTED SCREEN, GM = GEOMON

RECORDER _____

AEP_Mt.LBR.LF.FKA.SI.GPJ.AEP.GDT.7/23/15

AMERICAN ELECTRIC POWER SERVICE CORPORATION
AEP CIVIL ENGINEERING LABORATORY
 LOG OF BORING



JOB NUMBER _____

COMPANY **APPALACHIAN POWER COMPANY**

BORING NO. **B-1201** DATE **7/23/15** SHEET **2** OF **2**

PROJECT **MOUNTAINEER LBR LANDFILL**

BORING START **1/10/12** BORING FINISH **1/10/12**

SAMPLE NUMBER	SAMPLE	SAMPLE DEPTH IN FEET		STANDARD PENETRATION RESISTANCE BLOWS / 6"	TOTAL LENGTH RECOVERY	RQD	DEPTH IN FEET	GRAPHIC LOG	USCS	SOIL / ROCK IDENTIFICATION	WELL	DRILLER'S NOTES
		FROM	TO			%						
15	SPT	21.0	22.5	3-4-7	1.4					CLAY 1.0 tsf, wet		
16	SPT	22.5	24.0	4-4-10	1.2					STIFF MEDIUM GRAY N5 SANDY CLAY 1.0 tsf, wet		
17	SPT	24.0	25.5	5-15-24	1.5					STIFF MODERATE BROWN 5YR 4/4 CLAY 1.5 tsf, wet		
18	SPT	25.5	27.0	17-47-50/.3	1.3		25			HARD GREENISH GRAY 5GY 6/1 CLAYSHALE wet w/rock fragments throughout		
19	SPT	27.0	28.5	5-45-50/.3	1.3					HARD GREENISH GRAY 5GY 6/1 CLAYSHALE wet		
20	SPT	28.5	30.0	8-27-50/.3	1.3					HARD DUSKY YELLOW GREEN 5GY 5/2 CLAYSHALE wet		
							30			HARD DUSKY YELLOW GREEN 5GY 5/2 CLAYSHALE wet		



Arcadis 2016

Boring Logs

**MW-1611, MW-1612, SB-1602,
SB-1609R, SB-1610, SB-1619R,
SB-1619R ALT**

AMERICAN ELECTRIC POWER SERVICE CORPORATION
AEP CIVIL ENGINEERING LABORATORY
 LOG OF BORING

JOB NUMBER OH015976.0009

COMPANY American Electric Power

PROJECT Mountaineer Plant

COORDINATES N 711,948.8 E 1,731,867.6

GROUND ELEVATION 654.0 SYSTEM _____

BORING NO. MW-1611 DATE 09/22/16 SHEET 1 OF 3

BORING START 06/02/16 BORING FINISH 06/02/16

PIEZOMETER TYPE NA WELL TYPE _____

HGT. RISER ABOVE GROUND 2.89 DIA _____

DEPTH TO TOP OF WELL SCREEN _____ BOTTOM _____

WELL DEVELOPMENT _____ BACKFILL _____

FIELD PARTY NA RIG Hollow Stem Auger

Water Level, ft	▽	▼	▼
TIME			
DATE			

SAMPLE NUMBER	SAMPLE	SAMPLE DEPTH IN FEET		STANDARD PENETRATION RESISTANCE BLOWS / 6"	TOTAL LENGTH RECOVERY	RQD %	DEPTH IN FEET	GRAPHIC LOG	USCS	SOIL / ROCK IDENTIFICATION	WELL	DRILLER'S NOTES
		FROM	TO									
0	NR	0.0	10.0		0							
							5					
							10					
1	SS	10.0	12.0	2-3-3-3	0.3					FILL, brown, very soft, slightly silty fill.		
2	SS	12.0	14.0	0-0-2-3	24				CL	Clay; some silt; moist; soft; medium plasticity; medium tough; (5Y 4/1).		

TYPE OF CASING USED

	NQ-2 ROCK CORE	
NA	6" x 3.25 HSA	
NA	9" x 6.25 HSA	
NA	HW CASING ADVANCER	4"
NA	NW CASING	3"
NA	SW CASING	6"
NA	AIR HAMMER	8"

Continued Next Page

PIEZOMETER TYPE: PT = OPEN TUBE POROUS TIP, SS = OPEN TUBE SLOTTED SCREEN, G = GEONOR, P = PNEUMATIC
 WELL TYPE: OW = OPEN TUBE SLOTTED SCREEN, GM = GEOMON

RECORDER J. Wanner

AEP - AEP.GDT - 09/22/16 10:24 - C:\CHERYL\PROJECTS\AEP MOUNTAINEER 7-2016 REV\AEP MOUNTAINEER.GPJ

AMERICAN ELECTRIC POWER SERVICE CORPORATION
AEP CIVIL ENGINEERING LABORATORY
 LOG OF BORING







JOB NUMBER OH015976.0009

COMPANY American Electric Power

BORING NO. MW-1611 DATE 09/22/16 SHEET 2 OF 3

PROJECT Mountaineer Plant

BORING START 06/02/16 BORING FINISH 06/02/16

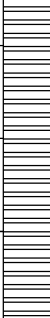
SAMPLE NUMBER	SAMPLE	SAMPLE DEPTH IN FEET		STANDARD PENETRATION RESISTANCE BLOWS / 6"	TOTAL LENGTH RECOVERY	RQD	DEPTH IN FEET	GRAPHIC LOG	USCS	SOIL / ROCK IDENTIFICATION	WELL	DRILLER'S NOTES
		FROM	TO			%						
3	SS	14.0	16.0	0-0-1-2	24		15					
4	SS	16.0	18.0	0-0-0-0	24				CL	Clay with silt; little to some sand, fine to medium; soft; low plasticity; low toughness; moist; color 5GY 6/1 (greenish gray); bottom 0.5 feet includes 10% gravel.		
5	SS	18.0	20.0	3-4-3-5	19							
6	SS	20.0	22.0	21-22-24-31	12		20			Note: From 20 to 22 feet moist; color grades to (5/56-1).		
7	SS	22.0	24.0		0.3					Weathered shale; dry; fine pastes; weak plates; very faint iron staining.		
8	SS	24.0	26.0		24					Straight drilled using a tricone bit, weathered bedrock.		
9	RC	26.0	30.5		60	60				Sandstone; field strength strong; color 10YR 6/3 to 10YR 5/2; texture medium grained; structure thinly bedded; decomposition slight; disintegration slight; fracture density intensely slight to very intense.		

AEP - AEP.GDT - 09/22/16 10:24 - C:\CHERYL\PROJECTS\AEP MOUNTAINEER 7-2016 REV\AEP MOUNTAINEER.GPJ

Continued Next Page

AMERICAN ELECTRIC POWER SERVICE CORPORATION
AEP CIVIL ENGINEERING LABORATORY
 LOG OF BORING

JOB NUMBER OH015976.0009

COMPANY American Electric Power

BORING NO. MW-1611 DATE 09/22/16 SHEET 3 OF 3

PROJECT Mountaineer Plant

BORING START 06/02/16 BORING FINISH 06/02/16

SAMPLE NUMBER	SAMPLE	SAMPLE DEPTH IN FEET		STANDARD PENETRATION RESISTANCE BLOWS / 6"	TOTAL LENGTH RECOVERY	RQD	DEPTH IN FEET	GRAPHIC LOG	USCS	SOIL / ROCK IDENTIFICATION	WELL	DRILLER'S NOTES
		FROM	TO			%						
10	RC	30.5	35.5		62.4	58						
							35			Sandstone; field strength strong; color N 3/ (very dark gray) to N 6/ (gray); texture medium grained; structure thinly bedded, cross-bedded; decomposition fresh; disintegration competent; fracture density none unfractured.		
11	RC	35.5	40.7		55.2	79			CL	Shale; field strength very weak to moderate; color N5/ (gray) to 10Y 5/1 (greenish gray); texture medium grained; structure thinly bedded; decomposition slightly; disintegration slightly; fracture density moderate to intense. Claystone/Mudstone; field strength moderate to strong; color 7.5R 3/3; texture fine grained; structure thinly bedded; decomposition slightly; disintegration slightly; fracture density moderate to intensely. Muddy shale; field strength strong; color 10BG 4/1 (dark greenish gray) to 5BG 4/1 (dark greenish gray); texture fine grained; structure thinly bedded; decomposition slightly; disintegration slightly; fracture density moderately to intensely.		
12	RC	40.7	46.0		57.6	39			CL	Claystone/Mudstone; field strength strong; color N 2.5/ (black) to 5GY 4/1 (dark greenish gray); texture fine grained; structure massive; decomposition moderately; disintegration slightly to moderately; fracture density intensely. Claystone/Mudstone; field strength strong; color 5GY 4/1 (dark greenish gray); texture fine grained; structure massive; decomposition slightly; disintegration slightly; fracture density moderately.		
							45			End of boring at 46 feet.		

AEP - AEP.GDT - 09/22/16 10:24 - C:\CHERYL\PROJECTS\AEP MOUNTAINEER 7-2016 REV\AEP MOUNTAINEER.GPJ

**AMERICAN ELECTRIC POWER SERVICE CORPORATION
AEP CIVIL ENGINEERING LABORATORY
LOG OF BORING**

JOB NUMBER OH015976.0009

COMPANY American Electric Power

PROJECT Mountaineer Plant

COORDINATES N 709,978.5 E 1,727,983.1

GROUND ELEVATION 780.7 SYSTEM _____

BORING NO. MW-1612 DATE 09/22/16 SHEET 1 OF 9

BORING START 07/12/16 BORING FINISH 07/14/16

PIEZOMETER TYPE NA WELL TYPE OW

HGT. RISER ABOVE GROUND 2.57 DIA 2"

DEPTH TO TOP OF WELL SCREEN 101 BOTTOM 121

WELL DEVELOPMENT NA BACKFILL Grout

FIELD PARTY NA RIG Hollow Stem Auger

Water Level, ft	<u>▽</u>	<u>▼</u>	<u>▼</u>
TIME			
DATE			

SAMPLE NUMBER	SAMPLE	SAMPLE DEPTH IN FEET		STANDARD PENETRATION RESISTANCE BLOWS / 6"	TOTAL LENGTH RECOVERY	RQD %	DEPTH IN FEET	GRAPHIC LOG	USCS	SOIL / ROCK IDENTIFICATION	WELL	DRILLER'S NOTES
		FROM	TO									
0	NR	0.0	8.0		0					Straight drilled to 8 feet, boring was pre-drilled for utility clearance; no samples were taken.		
1	SS	8.0	10.0	2-6-9-12	21		5		CL	Clay; trace silt; medium to high plasticity; no dilatancy; moist; stiff; yellowish red (5YR 4/6).		
2	SS	10.0	12.0	6-7-9-9	23		10		CL	Clay; little silt; trace very fine sand; medium plasticity; no dilatancy; moist; very stiff; yellowish brown (10YR 5/4) with trace stone brown and light gray (75YR 5/8).		
3	SS	12.0	14.0	3-6-9-9	26					Note: At 13 feet color changes to strong brown (7.5YR 4/6).		
4	SS	14.0	16.0	2-6-9-10	28					Note: At 13.1 feet lens of poorly sorted sand, fine to very coarse; and granules; angular, black. Note: From 14 to 16 feet strong brown; 10%		

TYPE OF CASING USED

	NQ-2 ROCK CORE
NA	6" x 3.25 HSA
NA	9" x 6.25 HSA
NA	HW CASING ADVANCER 4"
NA	NW CASING 3"
NA	SW CASING 6"
NA	AIR HAMMER 8"

Continued Next Page

PIEZOMETER TYPE: PT = OPEN TUBE POROUS TIP, SS = OPEN TUBE SLOTTED SCREEN, G = GEONOR, P = PNEUMATIC

WELL TYPE: OW = OPEN TUBE SLOTTED SCREEN, GM = GEOMON

RECORDER K. Eldridge

AEP - AEP.GDT - 09/22/16 10:30 - C:\CHERYL\PROJECTS\AEP MOUNTAINEER 7-2016 REV\AEP MOUNTAINEER.GPJ

AMERICAN ELECTRIC POWER SERVICE CORPORATION
AEP CIVIL ENGINEERING LABORATORY
 LOG OF BORING

JOB NUMBER **OH015976.0009**

COMPANY **American Electric Power**

BORING NO. **MW-1612** DATE **09/22/16** SHEET **2** OF **9**

PROJECT **Mountaineer Plant**

BORING START **07/12/16** BORING FINISH **07/14/16**

SAMPLE NUMBER	SAMPLE	SAMPLE DEPTH IN FEET		STANDARD PENETRATION RESISTANCE BLOWS / 6"	TOTAL LENGTH RECOVERY	RQD	DEPTH IN FEET	GRAPHIC LOG	USCS	SOIL / ROCK IDENTIFICATION	WELL	DRILLER'S NOTES
		FROM	TO			%						
5	SS	16.0	18.0	3-5-7-8	26					light gray; 1% black; no sand.		
6	SS	18.0	20.0	3-6-7-8	25							
							20		CL	Clay; trace silt; some very fine sand; low plasticity; moist; very stiff; strong brown with approximately 3% light gray (7.5YR 5/6).		
7	SS	20.0	22.0	4-6-7-6	20				CL	Clay, little silt; trace fine sand; trace weathered fragments sandstone, olive (5Y 5/3); medium plasticity; very stiff; moist; strong brown (7.5YR 4/6) with 10% black (7.5YR 2 5/1).		
8	SS	22.0	24.0	2-6-17-18	19							
									CL	Clay; some silt; low to medium plasticity; no dilatancy; dry; yellowish brown (10YR 5/6) with 10% dark brown (10YR 3/3).		
9	SS	24.0	26.0	50/4-7	2					Weathered shale; dry; (10YR 5/6).		
							25			Sandstone; field strength weak; color 2.5 Y 5/4 light olive brown with orange oxidize lamination; texture fine grained; structure laminated; decomposition slight; disintegration slight; fracture density intense.		
10	RC	26.5	27.7		14.4							
11	RC	27.7	32.6		59					Sandstone; field strength strong; color 5Y 4/2, (olive gray) to 5B 5/1 (bluish gray) with orange oxidize lamination; texture fine grained; structure laminated; decomposition slight; disintegration slight; fracture density moderate.		
							30					
12	RC	32.6	36.2		43							

AEP - AEP.GDT - 09/22/16 10:30 - C:\CHERYL\PROJECTS\AEP MOUNTAINEER 7-2016 REV\AEP MOUNTAINEER.GPJ

Continued Next Page

AMERICAN ELECTRIC POWER SERVICE CORPORATION
AEP CIVIL ENGINEERING LABORATORY
 LOG OF BORING

JOB NUMBER OH015976.0009

COMPANY American Electric Power

BORING NO. MW-1612 DATE 09/22/16 SHEET 3 OF 9

PROJECT Mountaineer Plant

BORING START 07/12/16 BORING FINISH 07/14/16

SAMPLE NUMBER	SAMPLE	SAMPLE DEPTH IN FEET		STANDARD PENETRATION RESISTANCE BLOWS / 6"	TOTAL LENGTH RECOVERY	RQD	DEPTH IN FEET	GRAPHIC LOG	USCS	SOIL / ROCK IDENTIFICATION	WELL	DRILLER'S NOTES
		FROM	TO			%						
							35					
13	RC	36.2	41.9		68			CL		Shale; field strength very strong; color 10Y 4/1 (dark greenish gray) to 5GY 5/1 (greenish gray) with trace oxidize lamination; texture fine grained; structure laminated; decomposition high; disintegration slight; fracture density intense. Claystone/Mudstone; field strength very weak; color 5R 3/2 (dusky red) and 10BG 4/1 (dark greenish gray); texture fine grained; structure massive; decomposition high; disintegration slight; fracture density intense.		
							40					
14	RC	41.9	46.9		60					Shale; field strength very weak; color 10G 4/1 (dark greenish gray); texture fine grained; structure laminated; decomposition slight; disintegration slight; fracture density moderate.		
							45					
15	RC	46.9	51.5		55					Sandstone; field strength strong; color 10BG 5/1 (greenish gray); texture fine grained; structure massive; decomposition fresh; disintegration slight; fracture density moderate.		
							50					
16	RC	51.5	57.9		60.36					Shale trace calcite fossil; field strength moderate to strong; color 10G 4/1 (dark greenish gray) to 5B 4/1 (dark bluish gray); texture fine grained; structure laminated; decomposition slight; disintegration slight; fracture density moderate. Shale; field strength strong; color 5B 4/1 (dark bluish gray); texture fine grained; structure laminated; decomposition slight; disintegration slight; fracture density moderate.		

AEP - AEP.GDT - 09/22/16 10:30 - C:\CHERYL\PROJECTS\AEP MOUNTAINEER 7-2016 REV\AEP MOUNTAINEER.GPJ

Continued Next Page

AMERICAN ELECTRIC POWER SERVICE CORPORATION
AEP CIVIL ENGINEERING LABORATORY
 LOG OF BORING





JOB NUMBER OH015976.0009

COMPANY American Electric Power

BORING NO. MW-1612 DATE 09/22/16 SHEET 4 OF 9

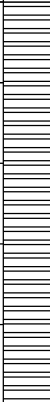
PROJECT Mountaineer Plant

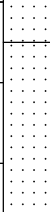
BORING START 07/12/16 BORING FINISH 07/14/16

SAMPLE NUMBER	SAMPLE	SAMPLE DEPTH IN FEET		STANDARD PENETRATION RESISTANCE BLOWS / 6"	TOTAL LENGTH RECOVERY	RQD	DEPTH IN FEET	GRAPHIC LOG	USCS	SOIL / ROCK IDENTIFICATION	WELL	DRILLER'S NOTES
		FROM	TO			%						
17	RC	57.9	60.8		34.8		55					
18	RC	60.8	126.3		54		60			Sandstone with some shale; field strength very strong; color 5B 4/1 (dark bluish gray); texture fine grained; structure massive; decomposition slight to fresh; disintegration competent; fracture density moderate.		
19	RC	65.5	67.5		31.56		65			Sandstone some shale; field strength strong to very strong; color 5B 4/1 (dark bluish gray); texture fine grained; structure medium to laminated; decomposition slight to fresh; disintegration competent; fracture density slight.		
20	RC	67.5	71.6		59.76					Sandstone; field strength very strong; color 5B 5/1 (bluish gray); texture fine grained; structure laminated with x-bedding; decomposition fresh; disintegration competent; fracture density none.		
							70		CL	Claystone/Mudstone; field strength very weak; color 5R 3/4 (dusky red) and 5BG 4/1 (dark greenish gray); texture fine grained; structure massive; decomposition slight; disintegration slight; fracture density moderate.		
21	RC	71.6	77.6		58.92				CL	Claystone/Mudstone; field strength very weak; color 10R 3/4; texture fine grained; structure massive; decomposition fresh to slight; disintegration slight; fracture density moderate.		

AEP - AEP.GDT - 09/22/16 10:30 - C:\CHERYL\PROJECTS\AEP MOUNTAINEER 7-2016 REV\AEP MOUNTAINEER.GPJ

Continued Next Page

AMERICAN ELECTRIC POWER SERVICE CORPORATION
 AEP CIVIL ENGINEERING LABORATORY
 LOG OF BORING

JOB NUMBER OH015976.0009

COMPANY American Electric Power

BORING NO. MW-1612 DATE 09/22/16 SHEET 5 OF 9

PROJECT Mountaineer Plant

BORING START 07/12/16 BORING FINISH 07/14/16

SAMPLE NUMBER	SAMPLE	SAMPLE DEPTH IN FEET		STANDARD PENETRATION RESISTANCE BLOWS / 6"	TOTAL LENGTH RECOVERY	RQD	DEPTH IN FEET	GRAPHIC LOG	USCS	SOIL / ROCK IDENTIFICATION	WELL	DRILLER'S NOTES
		FROM	TO			%						
							75					
22	RC	77.6	81.6		58.8			CL		Claystone/Mudstone with cal fossil; field strength very strong; color 5BG 3/1 (very dark greenish gray); texture fine grained; structure massive; decomposition fresh to slight; disintegration slight; fracture density moderate. Shale; field strength very weak; color 5BG 4/1 (dark greenish gray); texture fine grained; structure laminated; decomposition fresh; disintegration competent; fracture density intense.		
23	RC	81.6	86.4		51		80			Sandstone with trace calc. fossil; field strength very strong; color 5BG 4/1 (dark greenish gray); texture fine grained; structure massive; decomposition fresh; disintegration competent; fracture density slight.		
							85		CL	Claystone/Mudstone; field strength moderate; color 2.5R 2.5/3 and trace 10G 4/1 (dark greenish gray); texture fine grained; structure massive; decomposition fresh; disintegration competent; fracture density moderate.		
24	RC	86.4	92.4		59.52					Shale and sandstone transition; field strength strong; color 5BG 6/1 (greenish gray); texture fine grained; structure laminated; decomposition fresh; disintegration competent; fracture density moderate.		
25	RC	92.4	95.4		48		90			Sandstone; field strength very strong; color 5B 5/1 (bluish gray); texture fine grained; structure laminated and x-bedding; decomposition fresh; disintegration competent; fracture density none.		

AEP - AEP.GDT - 09/22/16 10:30 - C:\CHERYL\PROJECTS\AEP MOUNTAINEER 7-2016 REV\AEP MOUNTAINEER.GPJ

Continued Next Page

AMERICAN ELECTRIC POWER SERVICE CORPORATION
AEP CIVIL ENGINEERING LABORATORY
 LOG OF BORING

JOB NUMBER OH015976.0009

COMPANY American Electric Power

BORING NO. MW-1612 DATE 09/22/16 SHEET 6 OF 9

PROJECT Mountaineer Plant

BORING START 07/12/16 BORING FINISH 07/14/16

SAMPLE NUMBER	SAMPLE	SAMPLE DEPTH IN FEET		STANDARD PENETRATION RESISTANCE BLOWS / 6"	TOTAL LENGTH RECOVERY	RQD	DEPTH IN FEET	GRAPHIC LOG	USCS	SOIL / ROCK IDENTIFICATION	WELL	DRILLER'S NOTES
		FROM	TO			%						
							95	CL		Claystone/Mudstone; field strength moderate; color 10R 2.5/2 and 10BG 4/1 (dark greenish gray); texture fine grained; structure massive; decomposition high; disintegration competent to slight; fracture density moderate to intense.		
26	RC	95.4	100.5		34.8							
							100			Sandstone with calc. fossil; field strength very strong; color 10B 5/1 (bluish gray); texture fine grained; structure massive; decomposition fresh; disintegration competent; fracture density none to moderate.		
27	RC	100.5	103.7		34.56							
							105					
28	RC	103.7	106.5		32.04							
							110					
29	RC	106.5	111.5		57.6							
30	RC	111.5	115.8		54							

AEP - AEP.GDT - 09/22/16 10:30 - C:\CHERYL\PROJECTS\AEP MOUNTAINEER 7-2016 REV\AEP MOUNTAINEER.GPJ

Continued Next Page

AMERICAN ELECTRIC POWER SERVICE CORPORATION
AEP CIVIL ENGINEERING LABORATORY
 LOG OF BORING

JOB NUMBER OH015976.0009

COMPANY American Electric Power

BORING NO. MW-1612 DATE 09/22/16 SHEET 7 OF 9

PROJECT Mountaineer Plant

BORING START 07/12/16 BORING FINISH 07/14/16

SAMPLE NUMBER	SAMPLE	SAMPLE DEPTH IN FEET		STANDARD PENETRATION RESISTANCE BLOWS / 6"	TOTAL LENGTH RECOVERY	RQD	DEPTH IN FEET	GRAPHIC LOG	USCS	SOIL / ROCK IDENTIFICATION	WELL	DRILLER'S NOTES
		FROM	TO			%						
							115					
31	RC	115.8	119.8		46.8							
							120			Shale; field strength moderate; color 5BG 4/1 (dark greenish gray) to 2.5 YR 2.5/4; texture fine grained; structure laminate; decomposition fresh; disintegration competent; fracture density slight.		
32	RC	119.8	124.2		46.8					Shale; field strength moderate; color 2.5 YR 2.5/4; texture fine grained; structure laminate; decomposition fresh; disintegration competent; fracture density intense to moderate.		
							125	CL		Claystone/Mudstone; field strength strong; color 10G 5/1 (greenish gray) and 10 R 3/4; texture fine grained; structure massive; decomposition fresh; disintegration competent; fracture density intense to moderate.		
33	RC	124.2	126.7		26.4					Claystone/Mudstone; field strength strong; color 10 R 3/4 trace 10G 5/1 (greenish gray); texture fine grained; structure massive; decomposition fresh; disintegration competent; fracture density slight.		
							130			Claystone/Mudstone; field strength strong; color 10 R 3/4 from 126.7 to 130.8 feet and 5BG 4/1 (dark greenish gray) from 130.8 to 131.6 feet; texture fine grained; structure massive; decomposition fresh; disintegration competent; fracture density moderate.		
34	RC	126.7	131.6		59.28							
35	RC	131.6	135.0		42.48					Sandstone and shale with some calc. fossil;		

AEP - AEP.GDT - 09/22/16 10:30 - C:\CHERYL\PROJECTS\AEP MOUNTAINEER 7-2016 REV\AEP MOUNTAINEER.GPJ

Continued Next Page

AMERICAN ELECTRIC POWER SERVICE CORPORATION
AEP CIVIL ENGINEERING LABORATORY
 LOG OF BORING

JOB NUMBER OH015976.0009

COMPANY American Electric Power

BORING NO. MW-1612 DATE 09/22/16 SHEET 8 OF 9

PROJECT Mountaineer Plant

BORING START 07/12/16 BORING FINISH 07/14/16

SAMPLE NUMBER	SAMPLE	SAMPLE DEPTH IN FEET		STANDARD PENETRATION RESISTANCE BLOWS / 6"	TOTAL LENGTH RECOVERY	RQD	DEPTH IN FEET	GRAPHIC LOG	USCS	SOIL / ROCK IDENTIFICATION	WELL	DRILLER'S NOTES
		FROM	TO			%						
										field strength very strong; color 5BG 4/1 (dark greenish gray); texture fine grained; structure massive; decomposition fresh; disintegration competent; fracture density slight.		
								CL		Claystone/Mudstone; field strength very strong; color 10 R 3/4; texture fine grained; structure massive; decomposition fresh; disintegration competent; fracture density slight.		
36	RC	135.0	140.2		60.24		135			Sandstone with trace calc. fossil; field strength very strong; color 5B 4/1 (dark bluish gray); texture fine grained; structure laminated; decomposition fresh; disintegration competent; fracture density slight.		
										Sandstone with trace calc. fossil; field strength very strong; color 5B 4/1 (dark bluish gray); texture fine grained; structure laminated and x-bedding; decomposition fresh; disintegration competent; fracture density slight.		
							140					
37	RC	140.2	145.3		60.6					Sandstone with calc. fossil; field strength very strong; color 5B 5/1 (bluish gray); texture fine grained; structure laminated cross bedding; decomposition fresh; disintegration competent; fracture density slight.		
							145			Shale with calc. fossil; field strength very strong; color 5B 3/1 (very dark bluish gray); texture fine grained; structure laminate; decomposition fresh; disintegration competent; fracture density slight.		
38	RC	145.3	150.2		59.64					Shale with calc. fossil; field strength strong to very strong; color 5B 3/1 (very dark bluish gray); texture fine grained; structure laminated; decomposition fresh; disintegration competent; fracture density moderate.		
										Sandstone; field strength very strong; color 10B 5/1 (bluish gray); texture fine grained; structure laminate; decomposition fresh; disintegration competent; fracture density moderate.		
							150					
39	RC	150.2	154.7		52.8					Sandstone; fields strength very strong; color 10B 5/1 (bluish gray); texture fine grained; structure laminate; decomposition fresh; disintegration competent; fracture density		

AEP - AEP.GDT - 09/22/16 10:30 - C:\CHERYL\PROJECTS\AEP MOUNTAINEER 7-2016 REV\AEP MOUNTAINEER.GPJ

Continued Next Page

AMERICAN ELECTRIC POWER SERVICE CORPORATION
AEP CIVIL ENGINEERING LABORATORY
 LOG OF BORING

JOB NUMBER OH015976.0009

COMPANY American Electric Power

BORING NO. MW-1612 DATE 09/22/16 SHEET 9 OF 9

PROJECT Mountaineer Plant

BORING START 07/12/16 BORING FINISH 07/14/16

SAMPLE NUMBER	SAMPLE	SAMPLE DEPTH IN FEET		STANDARD PENETRATION RESISTANCE BLOWS / 6"	TOTAL LENGTH RECOVERY	RQD	DEPTH IN FEET	GRAPHIC LOG	USCS	SOIL / ROCK IDENTIFICATION	WELL	DRILLER'S NOTES
		FROM	TO			%						
40	RC	154.7	159.5		55.2		155			slight. Sandstone; field strength very strong; color 10B 5/1 (bluish gray); texture medium grained; structure massive; decomposition fresh; disintegration competent; fracture density none. Claystone/Mudstone; field strength very strong; color 2.5YR 2.5/3; texture medium grained; structure massive; decomposition fresh; disintegration slight; fracture density intense. Shale; field strength very strong; color 5BG 4/1 (dark greenish gray); texture medium grained; structure laminated; decomposition fresh; disintegration slight; fracture density none. Claystone/Mudstone; field strength very strong; color 10B 5/1 (bluish gray); texture medium grained; structure massive; decomposition fresh; disintegration slight; fracture density intense. End of boring at 159.5 feet.		

**AMERICAN ELECTRIC POWER SERVICE CORPORATION
AEP CIVIL ENGINEERING LABORATORY
LOG OF BORING**

JOB NUMBER OH015976.0009

COMPANY American Electric Power

PROJECT Mountaineer Plant

COORDINATES _____

GROUND ELEVATION NA SYSTEM _____

Water Level, ft	<u>▽</u>	<u>▼</u>	<u>▼</u>
TIME			
DATE			

BORING NO. SB-1602 DATE 09/22/16 SHEET 1 OF 10

BORING START 05/20/16 BORING FINISH 05/26/16

PIEZOMETER TYPE NA WELL TYPE _____

HGT. RISER ABOVE GROUND _____ DIA _____

DEPTH TO TOP OF WELL SCREEN _____ BOTTOM _____

WELL DEVELOPMENT _____ BACKFILL _____

FIELD PARTY NA RIG CME75

SAMPLE NUMBER	SAMPLE	SAMPLE DEPTH IN FEET		STANDARD PENETRATION RESISTANCE BLOWS / 6"	TOTAL LENGTH RECOVERY	RQD %	DEPTH IN FEET	GRAPHIC LOG	USCS	SOIL / ROCK IDENTIFICATION	WELL	DRILLER'S NOTES	
		FROM	TO										
0	SS	0.0	12.5		0	NA							Straight drilled to 12.5 feet, boring was pre-drilled for utility clearance; no samples were taken.
							5						
							10						
1	RC	12.5	15.7		37.2	25%				Sandstone; field strength strong; color 5Y 5/4 grades to 5Y 4/2; texture fine grained; structure thinly bedded to massive; decomposition slight; disintegration slight; fracture density intense.			Note: Color grades to 2.5Y 5/3 down to 20.3 feet.
							15			Sandstone; field strength strong; color 5Y 5/4; texture fine grained; structure massive; decomposition fresh; disintegration slight; fracture density very intense.			

TYPE OF CASING USED

	NQ-2 ROCK CORE	
NA	6" x 3.25 HSA	
NA	9" x 6.25 HSA	
NA	HW CASING ADVANCER	4"
NA	NW CASING	3"
NA	SW CASING	6"
NA	AIR HAMMER	8"

Continued Next Page

PIEZOMETER TYPE: PT = OPEN TUBE POROUS TIP, SS = OPEN TUBE SLOTTED SCREEN, G = GEONOR, P = PNEUMATIC

WELL TYPE: OW = OPEN TUBE SLOTTED SCREEN, GM = GEOMON

RECORDER J. Wanner

AEP - AEP.GDT - 09/22/16 10:40 - C:\CHERYL\PROJECTS\AEP MOUNTAINEER 7-2016 REV\AEP MOUNTAINEER.GPJ

AMERICAN ELECTRIC POWER SERVICE CORPORATION
AEP CIVIL ENGINEERING LABORATORY
 LOG OF BORING

JOB NUMBER OH015976.0009

COMPANY American Electric Power

BORING NO. SB-1602 DATE 09/22/16 SHEET 2 OF 10

PROJECT Mountaineer Plant

BORING START 05/20/16 BORING FINISH 05/26/16

SAMPLE NUMBER	SAMPLE	SAMPLE DEPTH IN FEET		STANDARD PENETRATION RESISTANCE BLOWS / 6"	TOTAL LENGTH RECOVERY	RQD	DEPTH IN FEET	GRAPHIC LOG	USCS	SOIL / ROCK IDENTIFICATION	WELL	DRILLER'S NOTES
		FROM	TO			%						
										Sandstone inter layered with red bed; field strength moderate; color 7.5 R 4/2; texture fine grained; structure massive; decomposition fresh; disintegration slight; fracture density very intense.		
3	RC	24.5	25.2		8.4	100%	25			Shale; field strength strong; color 5GY 3/1 (very dark greenish gray) grades to 10GY 5/1 (greenish gray); texture fine grained; structure thinly bedded; decomposition fresh; disintegration slight; fracture density intense. Note: From 25 to 25.2 feet field strength is moderate.		
4	RC	25.2	31.0		67.8	96%				Claystone/Mudstone; field strength moderate; color 7.5 R 3/2; texture fine grained; structure massive; decomposition fresh; disintegration slight; fracture density moderate. Note: At 25.2 feet contact, clear.		
5	RC	31.0	36.0		50.4	72%				Shale; field strength strong; color 10GY 6/1 (greenish gray); texture fine grained; structure massive to thinly bedded; decomposition fresh; disintegration slight; fracture density moderate. Note: At 27 to 34 feet clear boundary into shale (blue).		
6	RC	36.0	39.9		50.4	21%				Shale; field strength strong; color 5GY 5/1 (greenish gray); texture fine grained; structure massive to thinly bedded; decomposition fresh; disintegration slight; fracture density intense to moderate.		
7	RC	39.9	41.0		0	0%	40			Claystone/Mudstone; field strength moderate; color 7.5 Y 5/2; texture fine grained; structure massive; decomposition fresh; disintegration slight; fracture density intense to moderate.		
8	RC	41.0	46.0		58.8	93%				Claystone/Mudstone; field strength weak; color 7.5 Y 5/2 grades to 7.5 Y 4/2; texture fine grained; structure massive; decomposition fresh; disintegration slight; fracture density very intense. No recovery inner barrier split.		
							45			Claystone/Mudstone; field strength moderate; color 7.5 YR 5/2 grades to 7.5 R 3/3 to 4/4; texture fine grained; structure thinly bedded; decomposition fresh; disintegration slight; fracture density intense to moderate.		

AEP - AEP.GDT - 09/22/16 10:40 - C:\CHERYL\PROJECTS\AEP MOUNTAINEER 7-2016 REV\AEP MOUNTAINEER.GPJ

Continued Next Page

AMERICAN ELECTRIC POWER SERVICE CORPORATION
AEP CIVIL ENGINEERING LABORATORY
 LOG OF BORING

JOB NUMBER OH015976.0009

COMPANY American Electric Power

BORING NO. SB-1602 DATE 09/22/16 SHEET 3 OF 10

PROJECT Mountaineer Plant

BORING START 05/20/16 BORING FINISH 05/26/16

SAMPLE NUMBER	SAMPLE	SAMPLE DEPTH IN FEET		STANDARD PENETRATION RESISTANCE BLOWS / 6"	TOTAL LENGTH RECOVERY	RQD	DEPTH IN FEET	GRAPHIC LOG	USCS	SOIL / ROCK IDENTIFICATION	WELL	DRILLER'S NOTES
		FROM	TO			%						
9	RC	46.0	48.0		19.2	78%				Claystone/Mudstone; field strength moderate; color grades to 7.5 R 5/1 to 3/2; texture fine grained; structure thinly bedded; decomposition fresh; disintegration slight; fracture density very intense.		
10	RC	48.0	51.0		31.2	25%				Claystone/Mudstone; field strength weak; color grades to 2.5 Y 5/3; texture fine grained; structure 48 to 50 feet thinly bedded at 50 to 51 feet massive; decomposition fresh to slight; disintegration slight; fracture density intense to moderate.		
11	RC	51.0	56.0		31.2	32%				Claystone/Mudstone; field strength strong; color 7.5 R 3/2 with 20% coarse mottles 10B 6/1; texture fine grained; structure massive; decomposition fresh; disintegration slight; fracture density intense to moderate.		
12	RC	56.0	61.0		58.8	92%				Claystone/Mudstone; field strength strong; color 7.5 R 3/3; texture fine grained; structure massive; decomposition fresh; disintegration slight; fracture density slightly fractured.		
										Transition.		
										Sandstone; field strength strong; color 5B 5/1 (bluish gray); texture fine grained; structure thinly bedded; decomposition fresh; disintegration slight; fracture density slightly fractured.		
13	RC	61.0	66.0		58.2	81%				Sandstone; field strength strong; color 5B 5/1 (bluish gray) grades to 5B 4/1 (dark bluish gray); texture fine grained; structure thinly bedded; decomposition slight to fresh; disintegration slight; fracture density moderate.		
										Sandy Shale; field strength strong; color 5B 5/1 (bluish gray) grades to 5B 4/1 (dark bluish gray); texture fine grained; structure thinly bedded; decomposition slight to fresh; disintegration slight; fracture density moderate.		
14	RC	66.0	71.0		60	97%				Shaly sandstone; field strength strong; color 10B 4/1 (dark bluish gray); texture fine grained; structure thinly bedded; decomposition fresh; disintegration competent; fracture density from 66 to 68 feet moderate from 69 to 71 feet intense. Note: From 68 to 69 feet fracture density very intense.		
15	RC	71.0	76.0		60	93%				Sandstone with interbedded shale, clear boundaries; field strength very strong; color 5B		

Continued Next Page

AEP - AEP.GDT - 09/22/16 10:40 - C:\CHERYL\PROJECTS\AEP MOUNTAINEER 7-2016 REV\AEP MOUNTAINEER.GPJ

AMERICAN ELECTRIC POWER SERVICE CORPORATION
AEP CIVIL ENGINEERING LABORATORY
 LOG OF BORING

JOB NUMBER OH015976.0009

COMPANY American Electric Power

BORING NO. SB-1602 DATE 09/22/16 SHEET 4 OF 10

PROJECT Mountaineer Plant

BORING START 05/20/16 BORING FINISH 05/26/16

SAMPLE NUMBER	SAMPLE	SAMPLE DEPTH IN FEET		STANDARD PENETRATION RESISTANCE BLOWS / 6"	TOTAL LENGTH RECOVERY		DEPTH IN FEET	GRAPHIC LOG	USCS	SOIL / ROCK IDENTIFICATION	WELL	DRILLER'S NOTES
		FROM	TO		RECOVERY	%						
							75			5/1 (bluish gray) and 5B 4/1 (dark bluish gray); texture fine grained; structure thinly bedded; cross bedded throughout; decomposition fresh; disintegration competent; fracture density moderate. Note: At 72 to 73 feet fresh undecomposed plant roots up to 3mm observed paleosol.		
16	RC	76.0	81.0		61.2	98%				Sandstone with interbedded shale, gradual to diffuse boundaries; field strength very strong; color 5B 5/1 (bluish gray) and 5B 4/1 (dark bluish gray); texture fine grained; structure thinly bedded; decomposition fresh; disintegration competent; fracture density moderate.		
							80			Shale weakling developed; field strength strong; color 81 to 82.5 feet 5B 4/1 (dark bluish gray) then at 82.5 to 84 feet 7.5 R 3/2; texture fine grained; structure thinly bedded; decomposition slight; disintegration slight; fracture density moderate grades to intense.		
17	RC	81.0	86.0		55.8	58%				Claystone/Mudstone; field strength moderate; color 10Y 5/1 (greenish gray) to N 3/ (very dark gray); texture fine grained; structure massive; decomposition slight; disintegration slight; fracture density moderate grades to intense.		
							85			Transition. Note: From 86 to 92.9 feet sandy fine paleosol.		
18	RC	86.0	91.0		60	78%				Claystone/Mudstone; field strength strong; color 7.5 R 3/4; texture fine grained; structure massive; decomposition fresh; disintegration slight; fracture density moderate to intense.		
							90			Claystone/Mudstone; field strength strong; color 7.5 R 4/3; texture fine grained; structure massive; decomposition fresh; disintegration competent; fracture density moderate to slight.		
19	RC	91.0	96.0		61.2	99%				Shale; field strength strong; color 10BG 4/1 (dark greenish gray) to 10BG 6/1 (greenish gray); texture fine grained; structure massive; decomposition fresh; disintegration competent; fracture density moderate to slight.		
							95					
20	RC	96.0	101.0		55.8	92%						

Continued Next Page

AEP - AEP.GDT - 09/22/16 10:40 - C:\CHERYL\PROJECTS\AEP MOUNTAINEER 7-2016 REV\AEP MOUNTAINEER.GPJ

AMERICAN ELECTRIC POWER SERVICE CORPORATION
AEP CIVIL ENGINEERING LABORATORY
 LOG OF BORING

JOB NUMBER OH015976.0009

COMPANY American Electric Power

BORING NO. SB-1602 DATE 09/22/16 SHEET 5 OF 10

PROJECT Mountaineer Plant

BORING START 05/20/16 BORING FINISH 05/26/16

SAMPLE NUMBER	SAMPLE	SAMPLE DEPTH IN FEET		STANDARD PENETRATION RESISTANCE BLOWS / 6"	TOTAL LENGTH RECOVERY	RQD	DEPTH IN FEET	GRAPHIC LOG	USCS	SOIL / ROCK IDENTIFICATION	WELL	DRILLER'S NOTES
		FROM	TO			%						
							100			Shale; field strength strong; color 5B 6/1 (bluish gray) to 10B 2.5/1 (bluish black); texture fine grained; structure thinly bedded and massive; decomposition slight; disintegration slight; fracture density intense. Transition; structure massive.		
21	RC	101.0	106.0		60	64%						
							105			Claystone/Mudstone; field strength strong; color 7.5 R 3/2 to 7.5 R 3/3; texture fine grained; structure massive; decomposition slight; disintegration slight; fracture density intense. Claystone/Mudstone; field strength strong; color 7.5 R 3/2; texture fine grained; structure massive; decomposition fresh; disintegration slight to competent; fracture density intense to very intense.		
22	RC	106.0	111.0		62.4	71%						
							110			Shale; field strength strong; color 10BG 4/1 (dark greenish gray); texture fine grained; structure thinly bedded; decomposition fresh; disintegration slight to competent; fracture density intense to very intense. Shale; field strength strong; color 10BG 6/1 (greenish gray to 5BG 3/1 (very dark greenish gray); texture fine grained; structure thinly bedded; decomposition fresh; disintegration competent; fracture density moderate to very intense.		
23	RC	111.0	116.0		56.4	83%						
							115			Sandstone; field strength strong; color 10BG 6/1 (greenish gray to 5BG 3/1 (very greenish gray); texture medium grained; structure massive; decomposition fresh; disintegration competent; fracture density moderate to very intense. Shale; field strength strong; color 10BG 6/1 (greenish gray to 5BG 3/1 (very dark greenish gray); texture fine grained; structure thinly bedded; decomposition fresh; disintegration competent; fracture density moderate to very intense.		
24	RC	116.0	121.0		56.4	92%						
							120			Sandstone; field strength strong; color 10BG 4/1 (dark greenish gray) to 5G 5/1 (greenish gray); texture fine grained; structure thinly bedded; cross bedding evident at 16 to 120 feet; decomposition fresh; disintegration competent; fracture density moderate. Shale grades to sandstone; field strength strong; color 10BG 4/1 (dark greenish gray) to 5G 5/1 (greenish gray); texture fine grained;		
25	RC	121.0	126.0		62.4	98%						

Continued Next Page

AEP - AEP.GDT - 09/22/16 10:40 - C:\CHERYL\PROJECTS\AEP MOUNTAINEER 7-2016 REV\AEP MOUNTAINEER.GPJ

AMERICAN ELECTRIC POWER SERVICE CORPORATION
AEP CIVIL ENGINEERING LABORATORY
 LOG OF BORING

JOB NUMBER OH015976.0009

COMPANY American Electric Power

BORING NO. SB-1602 DATE 09/22/16 SHEET 6 OF 10

PROJECT Mountaineer Plant

BORING START 05/20/16 BORING FINISH 05/26/16

SAMPLE NUMBER	SAMPLE	SAMPLE DEPTH IN FEET		STANDARD PENETRATION RESISTANCE BLOWS / 6"	TOTAL LENGTH RECOVERY	RQD	DEPTH IN FEET	GRAPHIC LOG	USCS	SOIL / ROCK IDENTIFICATION	WELL	DRILLER'S NOTES
		FROM	TO			%						
26	RC	126.0	131.0		54	74%	125			structure thinly bedded; cross bedded at 122 to 126 feet; decomposition fresh; disintegration competent; fracture density very intense at 121 to 121.3 feet and unfractured at 121.3 to 126 feet.		
										Shale; field strength strong; color 5B 4/1 (dark bluish gray) and 5B 7/1 (light bluish gray); texture fine grained; structure thinly bedded; decomposition fresh; disintegration competent; fracture density unfractured to slight.		
27	RC	131.0	136.0		57.6	92%	130			Sandstone; field strength strong; color 7.5YR 5/2 (brown) and 5B 4/1 (dark bluish gray); texture fine grained; structure thinly bedded; decomposition slight; disintegration slight; fracture density very intense; horizontal and up to 70 degrees.		
										Sandstone; bottom 2 feet shaly; field strength strong; color 10BG 4/1 (dark greenish gray); texture fine grained; structure massive to thinly bedded; decomposition fresh; disintegration competent; fracture density slight.		
28	RC	136.0	141.0		61.2	102%	135			Sandstone grades to shale; field strength strong; color 5B 4/1 (dark bluish gray) to 5B 5/1 (bluish gray); texture fine grained; structure massive grades to thinly bedded; decomposition fresh; disintegration competent; fracture density unfractured.		
29	RC	141.0	146.0		55.2	92%	140					
30	RC	146.0	151.0		58.8	68%	145					
										Note: From 149 to 150 feet fracture density intense; vertical and horizontal fractures.		

AEP - AEP.GDT - 09/22/16 10:40 - C:\CHERYL\PROJECTS\AEP MOUNTAINEER 7-2016 REV\AEP MOUNTAINEER.GPJ

Continued Next Page

AMERICAN ELECTRIC POWER SERVICE CORPORATION
AEP CIVIL ENGINEERING LABORATORY
 LOG OF BORING

JOB NUMBER OH015976.0009

COMPANY American Electric Power

BORING NO. SB-1602 DATE 09/22/16 SHEET 7 OF 10

PROJECT Mountaineer Plant

BORING START 05/20/16 BORING FINISH 05/26/16

SAMPLE NUMBER	SAMPLE	SAMPLE DEPTH IN FEET		STANDARD PENETRATION RESISTANCE BLOWS / 6"	TOTAL LENGTH RECOVERY	RQD	DEPTH IN FEET	GRAPHIC LOG	USCS	SOIL / ROCK IDENTIFICATION	WELL	DRILLER'S NOTES
		FROM	TO			%						
31	RC	151.0	156.0		60	46%				Claystone/Mudstone; field strength strong; color 7.5 R 3/3; texture fine grained; structure massive; decomposition slight; disintegration slight; fracture density intense to very intense.		
32	RC	156.0	161.0		62.4	83%	155			Shale; field strength strong; color 5B 4/1 (dark bluish gray) to 10B 3/1 (very dark bluish gray); texture fine grained; structure thinly bedded, weakly developed; decomposition slight; disintegration slight; fracture density intense.		
33	RC	161.0	166.0		48	56%	160			Claystone/Mudstone; field strength strong; color 7.5R 3/3 (dusty red); texture fine grained; structure massive; decomposition fresh to slight; disintegration competent to slight; fracture density intense to very intense.		
34	RC	166.0	171.0		74.4	96%	165					
35	RC	171.0	176.0		62.4	104%	170			Shale; field strength strong; color 10G 6/1 (greenish gray) to 5B 3/1 (very dark bluish gray); texture fine grained; structure massive; decomposition slight; disintegration slight; fracture density intense to very intense. Note: From 170 to 171 driller ran cleanout as part of this run. Shaly sandstone inter layered with sandy shale; gradual boundary; field strength strong; color 10B 6/1 (bluish gray) to 10BG 4/1 (dark greenish gray); texture fine grained; structure massive; decomposition fresh; disintegration competent; fracture density unfractured.		
							175					

AEP - AEP.GDT - 09/22/16 10:40 - C:\CHERYL\PROJECTS\AEP MOUNTAINEER 7-2016 REV\AEP MOUNTAINEER.GPJ

Continued Next Page

AMERICAN ELECTRIC POWER SERVICE CORPORATION
AEP CIVIL ENGINEERING LABORATORY
 LOG OF BORING

JOB NUMBER OH015976.0009

COMPANY American Electric Power

BORING NO. SB-1602 DATE 09/22/16 SHEET 8 OF 10

PROJECT Mountaineer Plant

BORING START 05/20/16 BORING FINISH 05/26/16

SAMPLE NUMBER	SAMPLE	SAMPLE DEPTH IN FEET		STANDARD PENETRATION RESISTANCE BLOWS / 6"	TOTAL LENGTH RECOVERY	RQD	DEPTH IN FEET	GRAPHIC LOG	USCS	SOIL / ROCK IDENTIFICATION	WELL	DRILLER'S NOTES
		FROM	TO			%						
36	RC	176.0	181.0		60	87%	180			Claystone/Mudstone finger interbed of weakly developed; field strength strong; color 10BG 5/1 (greenish gray); texture fine grained; structure massive; decomposition fresh; disintegration competent; fracture density slight. Sandy shale; field strength strong; color 10BG 5/1 (greenish gray); texture fine grained; structure massive; decomposition fresh; disintegration competent; fracture density slight.		
37	RC	181.0	186.0		55.8	85%	185			Sandy shale; field strength strong; color 10G 5/1; texture fine to medium grained; structure massive grades to thinly bedded; decomposition fresh; disintegration competent; fracture density slight.		
38	RC	186.0	191.0		55.2	33%	190		CL	Claystone/Mudstone; field strength strong; color 7.5R 4/2 (weak red) with 5Y 6/3 (pale olive); texture fine grained; structure massive; decomposition slight; disintegration slight; fracture density moderate.		
39	RC	191.0	196.0		62.4	71%	195		CL	Claystone/Mudstone; field strength strong; color 7.5 R 3/3; texture fine grained; structure massive; decomposition slight; disintegration slight; fracture density moderate to intense.		
40	RC	196.0	201.0		61.2	88%	200		CL	Claystone/Mudstone; field strength strong; color 7.5 R 3/3; texture fine grained; structure massive; decomposition slight; disintegration slight; fracture density moderate.		
41	RC	201.0	206.0		60	100%	200			Shaly sandstone; field strength strong; color 10B 4/1 (dark bluish gray) to 5B 6/1 (bluish gray); texture fine grained; structure massive; decomposition slight; disintegration slight; fracture density moderate.		

Continued Next Page

AEP - AEP.GDT - 09/22/16 10:40 - C:\CHERYL\PROJECTS\AEP MOUNTAINEER 7-2016 REV\AEP MOUNTAINEER.GPJ

AMERICAN ELECTRIC POWER SERVICE CORPORATION
AEP CIVIL ENGINEERING LABORATORY
 LOG OF BORING

JOB NUMBER OH015976.0009

COMPANY American Electric Power

BORING NO. SB-1602 DATE 09/22/16 SHEET 9 OF 10

PROJECT Mountaineer Plant

BORING START 05/20/16 BORING FINISH 05/26/16

SAMPLE NUMBER	SAMPLE	SAMPLE DEPTH IN FEET		STANDARD PENETRATION RESISTANCE BLOWS / 6"	TOTAL LENGTH RECOVERY	RQD	DEPTH IN FEET	GRAPHIC LOG	USCS	SOIL / ROCK IDENTIFICATION	WELL	DRILLER'S NOTES
		FROM	TO			%						
							205					
42	RC	206.0	211.0		56.4	89%						
							210					
43	RC	211.0	213.5		33	96%				Claystone/Mudstone; field strength strong; color 7.5 R 3/3; texture fine grained; structure massive; decomposition slight; disintegration slight; fracture density moderate grades to very intense.		
44	RC	213.5	216.0		27.6	74%						
							215					
45	RC	216.0	221.0		30	48%						
							220					
46	RC	221.0	235.4		175.2	96%				Shaly sandstone grades to sandy shale very fine; field strength strong; color 10G 4/1 (dark greenish gray); texture fine grained; structure massive grades to thinly bedded, weakly developed; decomposition fresh; disintegration slight; fracture density slight. Sandy shale; field strength strong; color 5BG 3/1 (very dark greenish gray); texture fine grained; structure thinly bedded; decomposition fresh; disintegration competent to slight; fracture density slight to moderate.		
							225					
										Claystone/Mudstone; field strength strong; color 7.5R 3/3 (dusky red); texture fine grained; structure massive; decomposition fresh; disintegration competent to slight; fracture density slight to moderate. Shale; field strength strong; color 5BG 3/1 (very dark greenish gray); texture fine grained;		

AEP - AEP.GDT - 09/22/16 10:40 - C:\CHERYL\PROJECTS\AEP MOUNTAINEER 7-2016 REV\AEP MOUNTAINEER.GPJ

Continued Next Page

AMERICAN ELECTRIC POWER SERVICE CORPORATION
 AEP CIVIL ENGINEERING LABORATORY
 LOG OF BORING



JOB NUMBER OH015976.0009

COMPANY American Electric Power

BORING NO. SB-1602 DATE 09/22/16 SHEET 10 OF 10

PROJECT Mountaineer Plant

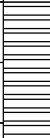
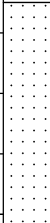
BORING START 05/20/16 BORING FINISH 05/26/16

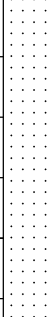
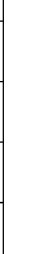
SAMPLE NUMBER	SAMPLE	SAMPLE DEPTH IN FEET		STANDARD PENETRATION RESISTANCE BLOWS / 6"	TOTAL LENGTH RECOVERY	RQD		DEPTH IN FEET	GRAPHIC LOG	USCS	SOIL / ROCK IDENTIFICATION	WELL	DRILLER'S NOTES
		FROM	TO			%	%						
								230			structure thinly bedded grades with massive; decomposition fresh; disintegration competent to slight; fracture density slight to moderate.		
								235			Shaly sandstone; field strength strong; color 5BG 3/1 (very dark greenish gray); texture fine grained; structure thinly bedded, cross bedded from 232 to 234 feet; decomposition fresh; disintegration competent to slight; fracture density slight to moderate.		
47	RC	235.4	241.0		56.4	84%		240			Shale grades with sandy shale (sand fraction is fine to medium); field strength strong; color 5B 5/1 (bluish gray); texture fine grained; structure thinly bedded with some cross bedding; decomposition fresh; disintegration competent; fracture density unfractured.		
48	RC	241.0	246.0		61.8	102%		245			Sandy shale grades to sandstone; field strength strong; color 10G 4/1 (dark greenish gray) to 10B 5/1 (bluish gray); texture fine grained grades to medium grained; structure massive grades to thinly bedded; decomposition fresh; disintegration competent; fracture density 241 to 241.4 feet very intensely fractured and from 241.4 to 246 feet unfractured.		
49	RC	246.0	251.0		44.4	68%		250			Claystone/Mudstone; field strength strong; color 7.5 R 3/2 to 7.5 R 3/3; texture fine grained; structure massive with faint layered appearance; decomposition fresh; disintegration competent; fracture density intense		
													End of boring at 251 feet.

AEP - AEP.GDT - 09/22/16 10:40 - C:\CHERYL\PROJECTS\AEP MOUNTAINEER 7-2016 REV\AEP MOUNTAINEER.GPJ

**AMERICAN ELECTRIC POWER SERVICE CORPORATION
AEP CIVIL ENGINEERING LABORATORY
LOG OF BORING**

JOB NUMBER **OH015976.0009**

COMPANY **American Electric Power**

PROJECT **Mountaineer Plant**

COORDINATES _____

GROUND ELEVATION **NA** SYSTEM _____

BORING NO. **SB-1609R** DATE **09/22/16** SHEET **1** OF **3**

BORING START **05/11/16** BORING FINISH **05/11/16**

PIEZOMETER TYPE **NA** WELL TYPE _____

HGT. RISER ABOVE GROUND _____ DIA _____

DEPTH TO TOP OF WELL SCREEN _____ BOTTOM _____

WELL DEVELOPMENT _____ BACKFILL _____

FIELD PARTY **NA** RIG **Hollow Stem Auger**

Water Level, ft	▽	▼	▼
TIME			
DATE			

SAMPLE NUMBER	SAMPLE	SAMPLE DEPTH IN FEET		STANDARD PENETRATION RESISTANCE BLOWS / 6"	TOTAL LENGTH RECOVERY	RQD %	DEPTH IN FEET	GRAPHIC LOG	USCS	SOIL / ROCK IDENTIFICATION	WELL	DRILLER'S NOTES
		FROM	TO									
0	NR	0.0	6.0		0					Straight drilled to 6 feet, boring was pre-drilled for utility clearance; no samples were taken.		
1	SS	6.0	8.0	1-0-0-2	24		5			Backfill; silt and sand.		
2	SS	8.0	10.0	6-6-8-9	12			ML CL		Clayey silt; most; low plastic; low tough; yellowish brown (10YR 5/4).		
3	SS	10.0	12.0	4-4-5-4	20		10	ML CL		Clayey silt; trace to little sand; trace to little fine gravel; dry; low plastic; medium toughness; color grades to reddish brown (5YR 4/4); massive; firm. Note: From 8 to 13.5 feet includes some coal fragments.		
4	SS	12.0	14.0	3-4-5-5	13							
5	SS	14.0	16.0	7-7-8-6	18					Note: From 13.5 to 13.6 feet sand lens, fine to medium; loose; dry. Note: From 14 to 16 feet includes <20% mottles; <15 mm in size; distinct contrast; very dark bluish gray (10B 3/1), and dark reddish gray (5R 4/1).		
6	SS	16.0	18.0	3-3-6-6	21		15	SP ML CL		Sand with silt; dry; loose; sand is fine to medium; brown (10YR 5/3). Silt with clay; little sand, fine to coarse; little grave, fine to coarse; dry; firm; reddish brown (5YR 4/4). Note: From 16 to 20 feet gradual increase in		
7	SS	18.0	20.0	1-2-4-4	24							

TYPE OF CASING USED

NA	NQ-2 ROCK CORE	
NA	6" x 3.25 HSA	
NA	9" x 6.25 HSA	
NA	HW CASING ADVANCER	4"
NA	NW CASING	3"
NA	SW CASING	6"
NA	AIR HAMMER	8"

Continued Next Page

PIEZOMETER TYPE: PT = OPEN TUBE POROUS TIP, SS = OPEN TUBE SLOTTED SCREEN, G = GEONOR, P = PNEUMATIC
WELL TYPE: OW = OPEN TUBE SLOTTED SCREEN, GM = GEOMON

RECORDER **J. Wanner**

AEP - AEP.GDT - 09/22/16 10:43 - C:\CHERYL\PROJECTS\AEP MOUNTAINEER 7-2016 REV\AEP MOUNTAINEER.GPJ

AMERICAN ELECTRIC POWER SERVICE CORPORATION
AEP CIVIL ENGINEERING LABORATORY
 LOG OF BORING

JOB NUMBER **OH015976.0009**

COMPANY **American Electric Power**

BORING NO. **SB-1609R** DATE **09/22/16** SHEET **2** OF **3**

PROJECT **Mountaineer Plant**

BORING START **05/11/16** BORING FINISH **05/11/16**

SAMPLE NUMBER	SAMPLE	SAMPLE DEPTH IN FEET		STANDARD PENETRATION RESISTANCE BLOWS / 6"	TOTAL LENGTH RECOVERY	RQD		DEPTH IN FEET	GRAPHIC LOG	USCS	SOIL / ROCK IDENTIFICATION	WELL	DRILLER'S NOTES
		FROM	TO			%							
								20			the abundance and size of mottles.		
8	SS	20.0	22.0	0-2-4-5	24								
9	SS	22.0	24.0	1-2-4-4	24					SM GM	Silt with sand; some gravel; some clay; moist; firm; massive; sand is fine to coarse; gravel is fine to coarse, angular dominant.; dark yellowish brown (10YR 4/4).		
10	SS	24.0	26.0	1-2-7-29	24			25		SM	Silt with very fine sand; some clay; dry; firm; massive; includes trace fine to medium, subangular gravel; very dark bluish gray (10B 3/1).		
11	SS	26.0	28.0	23-24-41-50/3	13					ML CL	Note: From 25.5 to 26 feet broken gravel or rock; dry. Silt with clay; moist; soft; yellowish brown (10YR 5/4).		
12	RC	28.0	30.0		24						Weathered shale; weak plates to 5mm; light brownish gray (2.5Y 6/2) with very dark gray (5YR 3/1) on plate surface.		
13	RC	30.0	31.0		3	0		30			Shale; strong field strength; 10B 5/1 (bluish gray); aphanitic texture; laminated structure; fresh (undecomposed); cross-bedding is prominent 31.0 to 36.0 feet.		
14	RC	31.0	36.0		60	69					Interbedded "Red bed" and blue-gray shale; decreasing shale with depth; intensely fractured to very intensely fractured.		
15	RC	36.0	41.0		63.6	74		35					
16	RC	41.0	44.5		30.6	14		40			Red clay stone or mudstone; weak to very weak field strength, with some recovery having moderate strength; 7.5R 4/2 (weak red); massive to laminated structure; (regionally known as a so-called 'red bed'); intensely fractured to very intensely fractured. Interbedded "red bed" and blue-gray shale; increasing shale with depth; intensely fractured		

Continued Next Page

AEP - AEP.GDT - 09/22/16 10:43 - C:\CHERYL\PROJECTS\AEP MOUNTAINEER 7-2016 REV\AEP MOUNTAINEER.GPJ

AMERICAN ELECTRIC POWER SERVICE CORPORATION
AEP CIVIL ENGINEERING LABORATORY
 LOG OF BORING

JOB NUMBER OH015976.0009

COMPANY American Electric Power

BORING NO. SB-1609R DATE 09/22/16 SHEET 3 OF 3

PROJECT Mountaineer Plant

BORING START 05/11/16 BORING FINISH 05/11/16

SAMPLE NUMBER	SAMPLE	SAMPLE DEPTH IN FEET		STANDARD PENETRATION RESISTANCE BLOWS / 6"	TOTAL LENGTH RECOVERY	RQD	DEPTH IN FEET	GRAPHIC LOG	USCS	SOIL / ROCK IDENTIFICATION	WELL	DRILLER'S NOTES
		FROM	TO			%						
17	RC	44.5	46.0		3.6	0	45			to very intensely fractured.		
18	RC	46.0	51.0		56.4	40						
19	RC	51.0	52.0		5.4	0						
20	RC	52.0	56.0		44.4	46						
21	RC	56.0	65.0		102	81						
							55			Shale, strong field strength; 10B 5/1 (bluish gray): aphanitic texture; laminated structure; fresh (undecomposed); cross-bedding is prominent.		
							60					
							65			End of boring at 65 feet.		

AEP - AEP.GDT - 09/22/16 10:43 - C:\CHERYL\PROJECTS\AEP MOUNTAINEER 7-2016 REV\AEP MOUNTAINEER.GPJ

AMERICAN ELECTRIC POWER SERVICE CORPORATION
AEP CIVIL ENGINEERING LABORATORY
 LOG OF BORING

JOB NUMBER OH015976.0009

COMPANY American Electric Power

PROJECT Mountaineer Plant

COORDINATES _____

GROUND ELEVATION NA SYSTEM _____

BORING NO. SB-1610 DATE 09/22/16 SHEET 1 OF 14

BORING START 06/14/16 BORING FINISH 06/16/16

PIEZOMETER TYPE NA WELL TYPE _____



HGT. RISER ABOVE GROUND _____ DIA _____

DEPTH TO TOP OF WELL SCREEN _____ BOTTOM _____

WELL DEVELOPMENT _____ BACKFILL _____

FIELD PARTY NA RIG CME75

Water Level, ft	▽	▽	▽
TIME			
DATE			

SAMPLE NUMBER	SAMPLE	SAMPLE DEPTH IN FEET		STANDARD PENETRATION RESISTANCE BLOWS / 6"	TOTAL LENGTH RECOVERY	RQD	DEPTH IN FEET	GRAPHIC LOG	USCS	SOIL / ROCK IDENTIFICATION	WELL	DRILLER'S NOTES
		FROM	TO			%						
0	NR	0.0	9.5		0							Straight drilled to 9.5 feet, boring was pre-drilled for utility clearance; no samples were taken.
1	RC	9.5	11.2		12	29	10			Sandstone; field strength moderate to strong; color 10 YR 5/4; texture medium grained; structure massive; decomposition slight; disintegration slight; fracture density moderate to intense.		
2	RC	11.2	15.9		57.6	52				Sandstone; field strength strong except at 15.6 to 15.8 feet is weak; color 10 YR 5/4 with 10 YR 3/4; texture medium grained; structure		

TYPE OF CASING USED

	NQ-2 ROCK CORE
NA	6" x 3.25 HSA
NA	9" x 6.25 HSA
NA	HW CASING ADVANCER 4"
NA	NW CASING 3"
NA	SW CASING 6"
NA	AIR HAMMER 8"

Continued Next Page

PIEZOMETER TYPE: PT = OPEN TUBE POROUS TIP, SS = OPEN TUBE SLOTTED SCREEN, G = GEONOR, P = PNEUMATIC

WELL TYPE: OW = OPEN TUBE SLOTTED SCREEN, GM = GEOMON

RECORDER J. Wanner

AEP - AEP.GDT - 09/22/16 10:45 - C:\CHERYL\PROJECTS\AEP MOUNTAINEER 7-2016 REV\AEP MOUNTAINEER.GPJ

AMERICAN ELECTRIC POWER SERVICE CORPORATION
AEP CIVIL ENGINEERING LABORATORY
 LOG OF BORING

JOB NUMBER OH015976.0009

COMPANY American Electric Power

BORING NO. SB-1610 DATE 09/22/16 SHEET 2 OF 14

PROJECT Mountaineer Plant

BORING START 06/14/16 BORING FINISH 06/16/16

SAMPLE NUMBER	SAMPLE	SAMPLE DEPTH IN FEET		STANDARD PENETRATION RESISTANCE BLOWS / 6"	TOTAL LENGTH RECOVERY	RQD	DEPTH IN FEET	GRAPHIC LOG	USCS	SOIL / ROCK IDENTIFICATION	WELL	DRILLER'S NOTES
		FROM	TO			%						
										thinly bedded; decomposition slight; disintegration slight; fracture density moderate to intense.		
3	RC	15.9	20.9		62.4	58	15			Sandstone; field strength strong; color 5PB 5/1 with 10 YR 3/4, and with 20% 5/5 PB; texture medium grained; structure thinly bedded, dipped non-horizontal; decomposition slight; disintegration slight; fracture density very intensely.		
										Sandstone; field strength strong; color 5B 4/1 (dark bluish gray) to 5PB 5/1 (bluish gray); texture medium grained; structure thinly bedded, dipped non-horizontal; decomposition slight; disintegration slight; fracture density very intensely.		
4	RC	20.9	25.9		58.8	78	20					
5	RC	25.9	30.9		57.6	41	25					

AEP - AEP.GDT - 09/22/16 10:45 - C:\CHERYL\PROJECTS\AEP MOUNTAINEER 7-2016 REV\AEP MOUNTAINEER.GPJ

Continued Next Page

AMERICAN ELECTRIC POWER SERVICE CORPORATION
AEP CIVIL ENGINEERING LABORATORY
 LOG OF BORING



JOB NUMBER OH015976.0009

COMPANY American Electric Power

BORING NO. SB-1610 DATE 09/22/16 SHEET 4 OF 14

PROJECT Mountaineer Plant

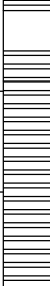
BORING START 06/14/16 BORING FINISH 06/16/16

SAMPLE NUMBER	SAMPLE	SAMPLE DEPTH IN FEET		STANDARD PENETRATION RESISTANCE BLOWS / 6"	TOTAL LENGTH RECOVERY	RQD	DEPTH IN FEET	GRAPHIC LOG	USCS	SOIL / ROCK IDENTIFICATION	WELL	DRILLER'S NOTES
		FROM	TO			%						
							45			Shaly sandstone; field strength strong; color 5BG 4/1 (dark greenish gray) to 5B 5/1 (bluish gray); texture fine grained; structure massive; decomposition slight to moderate; disintegration slight; fracture density none. Claystone/Mudstone; field strength strong; color 5BG 5/1 (greenish gray) to 7.5R 3/2 (dusky red); texture fine grained; structure massive; decomposition slight to moderate; disintegration slight; fracture density none.		
9	RC	45.9	50.9		63.6	44			CL	Shale; field strength strong; color 7.5 R 3/2 to 7.5 R 5/2; texture fine grained; structure massive; decomposition slight; disintegration slight; fracture density moderate. Claystone/Mudstone; field strength strong; color 5BG 4/1 (dark greenish gray) to 5B 5/1 (bluish gray); texture fine grained; structure massive; decomposition slight; disintegration slight; fracture density intense to very intense.		
							50			Sandy shale grades to sandstone; field strength strong; color 7.5 R 3/2 to 7.5 R 5/2; texture fine grained; structure massive; decomposition slight; disintegration slight; fracture density moderate.		
10	RC	50.9	55.9		55.8	83				Claystone/Mudstone; field strength strong; color 5BG 4/1 (dark greenish gray) to 5B 5/1 (bluish gray); texture fine grained; structure massive; decomposition slight; disintegration slight; fracture density intense to very intense. Shale; field strength strong; color 5B 3/1 (very bluish gray) to 10BG 4/1 (dark greenish gray); texture fine grained; structure massive; decomposition fresh to slight; disintegration slight; fracture density moderate.		
							55			Claystone/Mudstone; field strength strong to moderate; color 7.5 R 3/2 to 7.5 R 5/2; texture fine grained; structure massive; decomposition fresh to slight; disintegration slight; fracture density very intense.		
11	RC	55.9	60.9		61.2	63				Shale; field strength strong; color 3.5 B to 4/10 BG; texture fine grained; structure massive; decomposition fresh to slight; disintegration slight; fracture density moderate. Claystone/Mudstone; field strength strong; color 7.5 R 3/2 to 7.5 R 5/2; texture fine grained; structure massive; decomposition fresh to slight; disintegration slight; fracture density moderate to very intense.		
										Sandstone grades with Shaly sandstone; field		

Continued Next Page

AEP - AEP.GDT - 09/22/16 10:45 - C:\CHERYL\PROJECTS\AEP MOUNTAINEER 7-2016 REV\AEP MOUNTAINEER.GPJ

AMERICAN ELECTRIC POWER SERVICE CORPORATION
AEP CIVIL ENGINEERING LABORATORY
 LOG OF BORING

JOB NUMBER OH015976.0009

COMPANY American Electric Power

BORING NO. SB-1610 DATE 09/22/16 SHEET 5 OF 14

PROJECT Mountaineer Plant

BORING START 06/14/16 BORING FINISH 06/16/16

SAMPLE NUMBER	SAMPLE	SAMPLE DEPTH IN FEET		STANDARD PENETRATION RESISTANCE BLOWS / 6"	TOTAL LENGTH RECOVERY	RQD	DEPTH IN FEET	GRAPHIC LOG	USCS	SOIL / ROCK IDENTIFICATION	WELL	DRILLER'S NOTES
		FROM	TO			%						
							60			strength strong; color 5BG 4/1 (dark greenish gray) to 5B 5/1 (bluish gray); texture fine grained; structure thinly bedded; decomposition fresh; disintegration competent; fracture density slight.		
12	RC	60.9	65.9		62.4	103				Grades to shaly sandstone; field strength strong; color 4/5 BG to 5/5 B; texture fine grained; structure massive; decomposition slight; disintegration slight; fracture density moderate grades to slight.		
							65			Shale and claystone/mudstone; field strength weak to moderate; color 2.5 Y 5/2; texture fine grained; structure massive; decomposition moderate; disintegration moderate; fracture density moderate to very intense.		
13	RC	65.9	70.9		58.8	83				Shale; field strength moderate to strong; color 5BG 4/1 (dark greenish gray) to 5B 5/1 (bluish gray); texture fine grained; structure massive; decomposition fresh; disintegration competent; fracture density slight.		
							70			Grades to sandstone; field strength strong; color 4/5 BG to 5/5 B; texture fine grained; structure thin bedded cross bedded; decomposition fresh; disintegration competent; fracture density slight.		
14	RC	70.9	75.9		60	100						

AEP - AEP.GDT - 09/22/16 10:45 - C:\CHERYL\PROJECTS\AEP MOUNTAINEER 7-2016 REV\AEP MOUNTAINEER.GPJ

Continued Next Page

AMERICAN ELECTRIC POWER SERVICE CORPORATION
AEP CIVIL ENGINEERING LABORATORY
 LOG OF BORING

JOB NUMBER OH015976.0009

COMPANY American Electric Power

BORING NO. SB-1610 DATE 09/22/16 SHEET 6 OF 14

PROJECT Mountaineer Plant

BORING START 06/14/16 BORING FINISH 06/16/16

SAMPLE NUMBER	SAMPLE	SAMPLE DEPTH IN FEET		STANDARD PENETRATION RESISTANCE BLOWS / 6"	TOTAL LENGTH RECOVERY	RQD	DEPTH IN FEET	GRAPHIC LOG	USCS	SOIL / ROCK IDENTIFICATION	WELL	DRILLER'S NOTES
		FROM	TO			%						
							75					
15	RC	75.9	80.9		58.8	65						
							80	CL		Claystone/Mudstone; field strength strong; color 5B 3/1 (very dark bluish gray); texture fine grained; structure thinly bedded; decomposition slight; disintegration slight; fracture density intense.		
16	RC	80.9	85.9		58.8	98				Shaly sandstone grades with sandy shale; field strength strong; color 5BG 4/1 (dark greenish gray) to 5B 5/1 (bluish gray); texture fine grained; structure massive; decomposition fresh; disintegration slight; fracture density slight.		
							85					
17	RC	85.9	90.9		60	97						

AEP - AEP.GDT - 09/22/16 10:45 - C:\CHERYL\PROJECTS\AEP MOUNTAINEER 7-2016 REV\AEP MOUNTAINEER.GPJ

Continued Next Page

AMERICAN ELECTRIC POWER SERVICE CORPORATION
AEP CIVIL ENGINEERING LABORATORY
 LOG OF BORING



JOB NUMBER OH015976.0009

COMPANY American Electric Power

BORING NO. SB-1610 DATE 09/22/16 SHEET 7 OF 14

PROJECT Mountaineer Plant

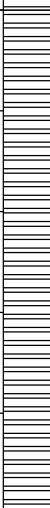
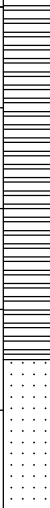
BORING START 06/14/16 BORING FINISH 06/16/16

SAMPLE NUMBER	SAMPLE	SAMPLE DEPTH IN FEET		STANDARD PENETRATION RESISTANCE BLOWS / 6"	TOTAL LENGTH RECOVERY	RQD	DEPTH IN FEET	GRAPHIC LOG	USCS	SOIL / ROCK IDENTIFICATION	WELL	DRILLER'S NOTES
		FROM	TO			%						
18	RC	90.9	95.9		52.8	80	95			Sandy shale; strong field strength; color 10Y 4/1 (dark greenish gray) to 5GY 5/1 (greenish gray); texture fine grained; massive structure; slight decomposition; moderately fractured.		
19	RC	95.9	100.9		61.2	98	100			Muddy shale; field strength strong; color 10Y 4/1 (dark greenish gray) to 5GY 5/1 (greenish gray); texture fine grained; structure massive; decomposition slight; disintegration slight; fracture density slight.		
20	RC	100.9	105.9		57.6	72	105			Note: At 102 feet slickenside.		
										Shaly sandstone; field strength strong; color 10BG 3/1 (very dark greenish gray); texture fine grained; structure massive; decomposition fresh; disintegration competent; fracture density none to slight.		

AEP - AEP.GDT - 09/22/16 10:45 - C:\CHERYL\PROJECTS\AEP MOUNTAINEER 7-2016 REV\AEP MOUNTAINEER.GPJ

Continued Next Page

AMERICAN ELECTRIC POWER SERVICE CORPORATION
 AEP CIVIL ENGINEERING LABORATORY
 LOG OF BORING

JOB NUMBER OH015976.0009

COMPANY American Electric Power

BORING NO. SB-1610 DATE 09/22/16 SHEET 8 OF 14

PROJECT Mountaineer Plant

BORING START 06/14/16 BORING FINISH 06/16/16

SAMPLE NUMBER	SAMPLE	SAMPLE DEPTH IN FEET		STANDARD PENETRATION RESISTANCE BLOWS / 6"	TOTAL LENGTH RECOVERY	RQD	DEPTH IN FEET	GRAPHIC LOG	USCS	SOIL / ROCK IDENTIFICATION	WELL	DRILLER'S NOTES
		FROM	TO			%						
21	RC	105.9	110.4		58.8	59				Sandy shale; field strength strong; color 5BG 4/1 (dark greenish gray) to 5B 5/1 (bluish gray); texture fine grained; structure massive; decomposition slight; disintegration slight; fracture density very intense grades to slight.		
22	RC	110.4	115.4		62.4	55	110		CL	Claystone/mudstone; field strength strong; color 7.5 R 3/2 to 7.5 R 5/2; texture fine grained; structure massive; decomposition slight; disintegration slight; fracture density very intense.		
23	RC	115.4	121.0		62.4	98	115			Sandy shale; field strength strong; color 10B 4/1 (dark bluish gray); texture fine grained; structure massive; decomposition fresh; disintegration competent; fracture density slight. Muddy shale grades to claystone/mudstone; field strength strong; color 10B 4/1 (dark bluish gray) grades to 7.5 R 3/3; texture fine grained; structure massive; decomposition slight; disintegration slight; fracture density intense.		
							120			Sandstone; field strength strong; color 10B 4/1 (dark bluish gray); texture fine grained; structure thinly bedded; decomposition fresh; disintegration competent; fracture density moderate to intense.		

AEP - AEP.GDT - 09/22/16 10:45 - C:\CHERYL\PROJECTS\AEP MOUNTAINEER 7-2016 REV\AEP MOUNTAINEER.GPJ

Continued Next Page

AMERICAN ELECTRIC POWER SERVICE CORPORATION
AEP CIVIL ENGINEERING LABORATORY
 LOG OF BORING







JOB NUMBER OH015976.0009

COMPANY American Electric Power

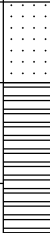
BORING NO. SB-1610 DATE 09/22/16 SHEET 9 OF 14

PROJECT Mountaineer Plant

BORING START 06/14/16 BORING FINISH 06/16/16

SAMPLE NUMBER	SAMPLE	SAMPLE DEPTH IN FEET		STANDARD PENETRATION RESISTANCE BLOWS / 6"	TOTAL LENGTH RECOVERY	RQD	DEPTH IN FEET	GRAPHIC LOG	U S C S	SOIL / ROCK IDENTIFICATION	WELL	DRILLER'S NOTES
		FROM	TO			%						
24	RC	121.0	126.0		39.6	34						
							125			Shale; field strength strong; color 10B 4/1 (dark bluish gray); texture fine grained; structure massive; decomposition slight; disintegration slight; fracture density slight to intense.		
									CL	Claystone/mudstone; field strength strong; color 7.5 R 3/3; texture fine grained; structure massive; decomposition slight; disintegration slight; fracture density slight to intense.		
25	RC	126.0	131.3		81.6	101						
							130			Transition; field strength strong; color 7.5 R 3/3 and 4/10 BG; texture fine grained; structure massive; decomposition fresh; disintegration competent; fracture density slight.		
										Sandstone; field strength strong; color 10B 4/1 (dark bluish gray); fine grained; structure massive; decomposition fresh; disintegration competent; fracture density slight.		
26	RC	131.3	136.3		51.6	78						
										Sandstone grades to shale; field strength strong; color 10B 4/1 (dark bluish gray); texture fine grained; structure massive; decomposition fresh; disintegration competent; fracture density slight.		
										Muddy shale grades to claystone/mudstone; field strength strong; color 10B 4/1 (dark bluish gray) and 7.5 R 4.2; texture fine grained; structure massive; decomposition fresh; disintegration competent; fracture density moderate.		
27	RC	136.3	141.3		54	60						
							135		CL	Claystone/mudstone; field strength strong; color 7.5 R 3/2 and 5/N grades to 2/5 y 5/4		

Continued Next Page

AEP - AEP.GDT - 09/22/16 10:45 - C:\CHERYL\PROJECTS\AEP MOUNTAINEER 7-2016 REV\AEP MOUNTAINEER.GPJ

AMERICAN ELECTRIC POWER SERVICE CORPORATION
AEP CIVIL ENGINEERING LABORATORY
 LOG OF BORING

JOB NUMBER OH015976.0009

COMPANY American Electric Power

BORING NO. SB-1610 DATE 09/22/16 SHEET 10 OF 14

PROJECT Mountaineer Plant

BORING START 06/14/16 BORING FINISH 06/16/16

SAMPLE NUMBER	SAMPLE	SAMPLE DEPTH IN FEET		STANDARD PENETRATION RESISTANCE BLOWS / 6"	TOTAL LENGTH RECOVERY	RQD	DEPTH IN FEET	GRAPHIC LOG	USCS	SOIL / ROCK IDENTIFICATION	WELL	DRILLER'S NOTES
		FROM	TO			%						
							140	[Hatched Pattern]		grades to 7.5 R 3/3; texture fine grained; structure massive; decomposition fresh to slight; disintegration slight; fracture density intense to very intense.		
28	RC	141.3	146.3		62.4	90						
							145	[Dotted Pattern]		Sandstone; field strength strong to very strong; color 10B 5/1 (bluish gray) to 10B 6/1 (bluish gray); texture medium grained; structure massive; decomposition fresh; disintegration competent; fracture density none.		
29	RC	146.3	151.3		61.8	103						
							150	[Dotted Pattern]		Sandstone; field strength strong to very strong; color 5/10 B to 6/10 B; texture medium grained; structure massive; decomposition fresh; disintegration competent; fracture density none.		
30	RC	151.3	156.3		61.8	103						

AEP - AEP.GDT - 09/22/16 10:45 - C:\CHERYL\PROJECTS\AEP MOUNTAINEER 7-2016 REV\AEP MOUNTAINEER.GPJ

Continued Next Page

AMERICAN ELECTRIC POWER SERVICE CORPORATION
AEP CIVIL ENGINEERING LABORATORY
 LOG OF BORING

JOB NUMBER OH015976.0009

COMPANY American Electric Power

BORING NO. SB-1610 DATE 09/22/16 SHEET 11 OF 14

PROJECT Mountaineer Plant

BORING START 06/14/16 BORING FINISH 06/16/16

SAMPLE NUMBER	SAMPLE	SAMPLE DEPTH IN FEET		STANDARD PENETRATION RESISTANCE BLOWS / 6"	TOTAL LENGTH RECOVERY	RQD	DEPTH IN FEET	GRAPHIC LOG	USCS	SOIL / ROCK IDENTIFICATION	WELL	DRILLER'S NOTES
		FROM	TO			%						
							155					
31	RC	156.3	160.7		51.6	85						
							160			Sandy shale grades to shale; field strength strong; color 5B 5/1 (bluish gray); texture fine grained; structure thinly bedded; decomposition fresh; disintegration competent to slight; fracture density slight.		
32	RC	160.7	165.7		61.2	44				Muddy shale; field strength strong; color 7.5 R 4/3; texture fine grained; structure thinly bedded; decomposition fresh; disintegration competent to slight; fracture density slight.		
									CL	Claystone/mudstone; field strength strong; color 7.5 R 3/3; texture fine grained; structure massive; decomposition slight; disintegration slight; fracture density very intense.		
										SHALE; field strength strong; color 5B 5/1 (bluish gray); texture fine grained; structure massive; decomposition slight; disintegration slight; fracture density none.		
										Claystone/mudstone; field strength strong; color 7.5 R 3/2 to 7.5 R 5/2; texture fine grained; structure massive; decomposition slight; disintegration slight; fracture density intense to very intense.		
33	RC	165.7	170.7		56.4	66	165					

Continued Next Page

AEP - AEP.GDT - 09/22/16 10:45 - C:\CHERYL\PROJECTS\AEP MOUNTAINEER 7-2016 REV\AEP MOUNTAINEER.GPJ

AMERICAN ELECTRIC POWER SERVICE CORPORATION
AEP CIVIL ENGINEERING LABORATORY
 LOG OF BORING



JOB NUMBER OH015976.0009

COMPANY American Electric Power

BORING NO. SB-1610 DATE 09/22/16 SHEET 12 OF 14

PROJECT Mountaineer Plant

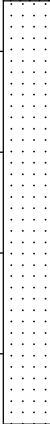
BORING START 06/14/16 BORING FINISH 06/16/16

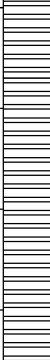
SAMPLE NUMBER	SAMPLE	SAMPLE DEPTH IN FEET		STANDARD PENETRATION RESISTANCE BLOWS / 6"	TOTAL LENGTH RECOVERY	RQD	DEPTH IN FEET	GRAPHIC LOG	USCS	SOIL / ROCK IDENTIFICATION	WELL	DRILLER'S NOTES
		FROM	TO			%						
							170					
34	RC	170.7	175.7		58.8	95				Sandstone; field strength strong; color 7.5 R 3/3 and 5B 5/1 (bluish gray); texture fine grained; structure massive; decomposition slight; disintegration slight; fracture density moderate to intense.		
							175		CL	Claystone/mudstone; field strength strong; color 7.5 R 3/3; texture fine grained; structure massive; decomposition fresh; disintegration competent; fracture density slight.		
35	RC	175.7	180.7		60	92				Sandy shale; field strength strong; color 5B 4/1 (dark bluish gray); structure thinly bedded; decomposition fresh; disintegration competent; fracture density none.		
							180			Sandy shale grades to shaly sandstone; field strength strong; color 5B 4/1 (dark bluish gray); structure thinly bedded; decomposition fresh; disintegration competent; fracture density none.		
36	RC	180.7	185.7		58.8	98						

AEP - AEP.GDT - 09/22/16 10:45 - C:\CHERYL\PROJECTS\AEP MOUNTAINEER 7-2016 REV\AEP MOUNTAINEER.GPJ

Continued Next Page

AMERICAN ELECTRIC POWER SERVICE CORPORATION
 AEP CIVIL ENGINEERING LABORATORY
 LOG OF BORING



JOB NUMBER OH015976.0009

COMPANY American Electric Power

BORING NO. SB-1610 DATE 09/22/16 SHEET 13 OF 14

PROJECT Mountaineer Plant

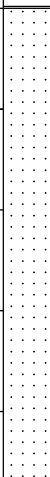
BORING START 06/14/16 BORING FINISH 06/16/16

SAMPLE NUMBER	SAMPLE	SAMPLE DEPTH IN FEET		STANDARD PENETRATION RESISTANCE BLOWS / 6"	TOTAL LENGTH RECOVERY	RQD	DEPTH IN FEET	GRAPHIC LOG	USCS	SOIL / ROCK IDENTIFICATION	WELL	DRILLER'S NOTES
		FROM	TO			%						
							185					
37	RC	185.7	190.7		62.4	99				Shale; field strength strong; color 5B 4/1 (dark bluish gray); texture fine grained; structure thinly bedded; decomposition fresh; disintegration competent; fracture density slight.		
							190					
38	RC	190.7	195.7		60	100				Sandstone; field strength strong; color 5B 4/1 (dark bluish gray); texture fine grained; structure thinly bedded; decomposition fresh; disintegration competent; fracture density slight.		
							195					
39	RC	195.7	200.7		55.2	90				Muddy shale; field strength strong; color 10BG 3/1 (very dark greenish gray and 7.5 R 3/2; texture fine grained; structure massive; decomposition fresh; disintegration competent; fracture density none.		

AEP - AEP.GDT - 09/22/16 10:45 - C:\CHERYL\PROJECTS\AEP MOUNTAINEER 7-2016 REV\AEP MOUNTAINEER.GPJ

Continued Next Page

AMERICAN ELECTRIC POWER SERVICE CORPORATION
AEP CIVIL ENGINEERING LABORATORY
 LOG OF BORING

JOB NUMBER OH015976.0009

COMPANY American Electric Power

BORING NO. SB-1610 DATE 09/22/16 SHEET 14 OF 14

PROJECT Mountaineer Plant

BORING START 06/14/16 BORING FINISH 06/16/16

SAMPLE NUMBER	SAMPLE	SAMPLE DEPTH IN FEET		STANDARD PENETRATION RESISTANCE BLOWS / 6"	TOTAL LENGTH RECOVERY	RQD	DEPTH IN FEET	GRAPHIC LOG	USCS	SOIL / ROCK IDENTIFICATION	WELL	DRILLER'S NOTES
		FROM	TO			%						
40	RC	200.7	205.1	51.6	67		200			Sandstone; field strength strong; color 5PB 4/1 (dark bluish gray) with 20% 7.5 R 4/3; texture fine grained; structure thinly bedded; decomposition slight; disintegration slight; fracture density moderate.		
							205			End of boring at 205.1 feet.		

**AMERICAN ELECTRIC POWER SERVICE CORPORATION
AEP CIVIL ENGINEERING LABORATORY
LOG OF BORING**

JOB NUMBER **OH015976.0009**

COMPANY **American Electric Power**

PROJECT **Mountaineer Plant**

COORDINATES _____

GROUND ELEVATION **NA** SYSTEM _____

Water Level, ft	▽	▼	▼
TIME			
DATE			

BORING NO. **SB-1619R (ALT)** DATE **09/22/16** SHEET **1** OF **2**

BORING START **05/12/16** BORING FINISH **05/12/16**



PIEZOMETER TYPE **NA** WELL TYPE _____

HGT. RISER ABOVE GROUND _____ DIA _____

DEPTH TO TOP OF WELL SCREEN _____ BOTTOM _____

WELL DEVELOPMENT _____ BACKFILL _____

FIELD PARTY **NA** RIG **Hollow Stem Auger**

SAMPLE NUMBER	SAMPLE	SAMPLE DEPTH IN FEET		STANDARD PENETRATION RESISTANCE BLOWS / 6"	TOTAL LENGTH RECOVERY	RQD %	DEPTH IN FEET	GRAPHIC LOG	USCS	SOIL / ROCK IDENTIFICATION	WELL	DRILLER'S NOTES
		FROM	TO									
	NR	0.0	6.0		0					Straight drilled to 6 feet, boring was pre-drilled for utility clearance; no samples were taken.		
1	SS	6.0	8.0	2-3-3-3	16		5		CL ML	Silt with clay; some sand, fine to coarse; trace gravel, fine to medium, subrounded, dry; firm; yellowish brown (10YR 5/4). Note: From 6 to 8 feet material was non-plastic. Note: From 7 to 8 feet includes some coal fragments.		
2	SS	8.0	10.0	1-1-3-2	13				CL ML CL ML CL ML	Sand with gravel; some silt; wet; loose; sand is fine to coarse; gravel is fine, subrounded. Silt with clay; trace fine to medium sand; dry; firm; non-plastic.		
3	SS	10.0	12.0	NM	24		10		CL ML CL ML	Silt; some clay; some fine sand; moist; soft; N 7/ (light gray). Clayey silt; moist; soft; medium plastic; low toughness; massive, N 5/ (gray). Note: At 10.5 feet trace coarse subangular gravel.		
4	SS	12.0	14.0	NM	24							
5	SS	14.0	16.0	NM	24							
TYPE OF CASING USED										<i>Continued Next Page</i>		
		NQ-2 ROCK CORE										
NA		6" x 3.25 HSA										
NA		9" x 6.25 HSA										
NA		HW CASING ADVANCER		4"								
NA		NW CASING		3"								
NA		SW CASING		6"								
NA		AIR HAMMER		8"								
										PIEZOMETER TYPE: PT = OPEN TUBE POROUS TIP, SS = OPEN TUBE SLOTTED SCREEN, G = GEONOR, P = PNEUMATIC		
										WELL TYPE: OW = OPEN TUBE SLOTTED SCREEN, GM = GEOMON		
										RECORDER J. Wanner		

AEP - AEP.GDT - 09/22/16 10:48 - C:\CHERYL\PROJECTS\AEP MOUNTAINEER 7-2016 REV\AEP MOUNTAINEER.GPJ

AMERICAN ELECTRIC POWER SERVICE CORPORATION
AEP CIVIL ENGINEERING LABORATORY
 LOG OF BORING



JOB NUMBER OH015976.0009

COMPANY American Electric Power

BORING NO. SB-1619R (ALT) DATE 09/22/16 SHEET 2 OF 2

PROJECT Mountaineer Plant

BORING START 05/12/16 BORING FINISH 05/12/16

SAMPLE NUMBER	SAMPLE	SAMPLE DEPTH IN FEET		STANDARD PENETRATION RESISTANCE BLOWS / 6"	TOTAL LENGTH RECOVERY	RQD	DEPTH IN FEET	GRAPHIC LOG	USCS	SOIL / ROCK IDENTIFICATION	WELL	DRILLER'S NOTES
		FROM	TO			%						
6	SS	16.0	18.0	0-0-0-3	24					mm in size, white quarts.		
7	SS	18.0	20.0	1-1-2-3	13				SM GM	Grades to silt; some sand, fine to coarse; some gravel, fine to medium, angular; little clay; dry; firm massive; non-plastic; non-dilatancy; 10B 4/1 (dark bluish gray). Note: At 18 to 20 feet dry; driller comments spoon had water in it.		
8	SS	20.0	22.0	1-4-5-3	14		20					
9	SS	22.0	24.0	3-5-5-6	20							
10	SS	24.0	26.0	3-5-7-7	13					Note: At 23 feet increase in common i.e. 10% area; medium; mottles; brown (7.5 YR 4/3).		
11	SS	26.0	28.0	4-8-10-6	13							
12	SS	28.0	30.0	3-5-8-6	13							
13	SS	30.0	32.0	4-23-30-41	0.7		30		CH	Clay; some silt; dry; hard to very hard; high plasticity; high toughness: dark reddish brown (2.5YR 3/4).		
14	SS	32.0	46.0	13-50/2	0.3					Weathered shale, no distinct plates; very hard; dry ; 5G 3/1 (very dark greenish gray).		
										End of boring at 33.2 feet refusal bedrock.		

AEP - AEP.GDT - 09/22/16 10:48 - C:\CHERYL\PROJECTS\AEP MOUNTAINEER 7-2016 REV\AEP MOUNTAINEER.GPJ

AMERICAN ELECTRIC POWER SERVICE CORPORATION
AEP CIVIL ENGINEERING LABORATORY
 LOG OF BORING

JOB NUMBER **OH015976.0009**

COMPANY **American Electric Power**

PROJECT **Mountaineer Plant**

COORDINATES _____

GROUND ELEVATION **NA** SYSTEM _____

BORING NO. **SB-1619R** DATE **09/22/16** SHEET **1** OF **2**

BORING START **05/11/16** BORING FINISH **05/11/16**

PIEZOMETER TYPE **NA** WELL TYPE _____



HGT. RISER ABOVE GROUND _____ DIA _____

DEPTH TO TOP OF WELL SCREEN _____ BOTTOM _____

WELL DEVELOPMENT _____ BACKFILL _____

FIELD PARTY **NA** RIG **Hollow Stem Auger**

Water Level, ft	▽	▼	▼
TIME			
DATE			

SAMPLE NUMBER	SAMPLE	SAMPLE DEPTH IN FEET		STANDARD PENETRATION RESISTANCE BLOWS / 6"	TOTAL LENGTH RECOVERY	RQD %	DEPTH IN FEET	GRAPHIC LOG	USCS	SOIL / ROCK IDENTIFICATION	WELL	DRILLER'S NOTES
		FROM	TO									
0	NR	0.0	6.0		0					Straight drilled to 6 feet, boring was pre-drilled for utility clearance; no samples were taken.		
1	SS	6.0	8.0	1-0-0-2	24		5			Backfill; silt and sand.		
2	SS	8.0	10.0	6-6-8-9	12		10		CL ML	Clayey silt; moist; low plasticity; low tough; yellowish brown (10YR 5/4).		
3	SS	10.0	12.0	4-4-5-4	20				CL ML	Clayey silt; trace to little sand; trace to little fine gravel; dry; low plasticity; medium toughness; massive; firm; color grades to reddish brown (5YR 4/4). Note: From 8 to 10 feet includes some coal fragments. Note: From 10 to 11 feet includes some coal fragments.		
4	SS	12.0	14.0	3-4-5-5	13							
5	SS	14.0	16.0	7-7-8-6	18					Note: From 13.5 to 13.6 feet sand lens; fine to coarse; loose; dry. Note: From 14 to 16 feet increase <20% mottles; <15 mm in size; distinct contrast; very		

TYPE OF CASING USED

NA	NQ-2 ROCK CORE	
NA	6" x 3.25 HSA	
NA	9" x 6.25 HSA	
NA	HW CASING ADVANCER	4"
NA	NW CASING	3"
NA	SW CASING	6"
NA	AIR HAMMER	8"

Continued Next Page

PIEZOMETER TYPE: PT = OPEN TUBE POROUS TIP, SS = OPEN TUBE SLOTTED SCREEN, G = GEONOR, P = PNEUMATIC

WELL TYPE: OW = OPEN TUBE SLOTTED SCREEN, GM = GEOMON

RECORDER **J. Wanner**

AEP - AEP.GDT - 09/22/16 10:47 - C:\CHERYL\PROJECTS\AEP MOUNTAINEER 7-2016 REV\AEP MOUNTAINEER.GPJ

AMERICAN ELECTRIC POWER SERVICE CORPORATION
AEP CIVIL ENGINEERING LABORATORY
 LOG OF BORING

JOB NUMBER OH015976.0009

COMPANY American Electric Power

BORING NO. SB-1619R DATE 09/22/16 SHEET 2 OF 2

PROJECT Mountaineer Plant

BORING START 05/11/16 BORING FINISH 05/11/16

SAMPLE NUMBER	SAMPLE	SAMPLE DEPTH IN FEET		STANDARD PENETRATION RESISTANCE BLOWS / 6"	TOTAL LENGTH RECOVERY	RQD	DEPTH IN FEET	GRAPHIC LOG	USCS	SOIL / ROCK IDENTIFICATION	WELL	DRILLER'S NOTES
		FROM	TO			%						
6	SS	16.0	18.0	3-3-6-6	21				SP CL ML	dark bluish gray (10B 3/1 (very dark bluish gray) and 5R 4/1 (dark bluish gray). Sand with silt; dry; loose; sand is fine to coarse; brown (10YR 5/3). Silt with clay; little sand, fine to coarse; little gravel; dry; firm; reddish brown (5YR 4/4). Note: From 16 to 20 feet granules increase in abundance and size of mottles.		
7	SS	18.0	20.0	1-2-4-4	24							
8	SS	20.0	22.0	0-2-4-5	24		20					
9	SS	22.0	24.0	1-2-4-4	24				SP SM	Silt with sand; some gravel; some clay; moist; firm; massive; sand is fine to coarse; gravel is fine to coarse, angular dominant; dark yellowish brown (10YR 4/4).		
10	SS	24.0	26.0	1-2-7-29	24				SM	Silt with very fine sand; some clay; dry; firm; massive; include trace fine to medium subangular gravel; 10B 3/1 (very dark bluish gray).		
11	SS	26.0	28.0	23-24-41-50/3	13				CL ML	Broken gravel or rock; dry. Silt with clay; moist; soft; yellowish brown (10YR 5/4). Weathered shale; up to 5 mm; light brownish gray (2.5Y 6/2) to very dark brown (5YR 3/1) at plate surfaces.		
										End of boring at 27.9 feet top of rock.		

AEP - AEP.GDT - 09/22/16 10:47 - C:\CHERYL\PROJECTS\AEP MOUNTAINEER 7-2016 REV\AEP MOUNTAINEER.GPJ



AEP 1986, 1992

**Monitoring Well Construction
Diagrams**

MW-1 to MW-20

COMPANY MOUNTAINNEER PLANT
 PROJECT ASH LANDFILL
 COORDINATES N.709,726.78 E.1,731,757.61
 DATE INSTALLED 7-25-86
 LATITUDE N. 38 56 43.00
 LONGITUDE W. 81 56 33.09

WELL CONSTRUCTION
 SUMMARY ELEVATION
 (ft. NGVD)
 WELL NO. MW-1
 REF. DATUM PT. 856.35
 GRADE 854.61

NOTE: CASING PROTECTOR DETAILS
 NOT SHOWN

- 1 GROUT SEAL CEMENT/BENTONITE
 - 2 BENTONITE SEAL
 - 3 GEOMON UNIT 1.25 POLETHYLENE
 - 4 GRAVEL PACK CONCRETE SAND
 - 5 CONTINUOUS UNKINKED NYLON TUBING EXTENDED TO TOP OF CHECK VALVE
 - 6 CASING 3/4 DIA. SCH. 80 PVC
 - 7 BRASS 'Y'FITTING
- MW-1 & MW-2 NESTED IN THE SAME
 3" DIAMETER BORE HOLE

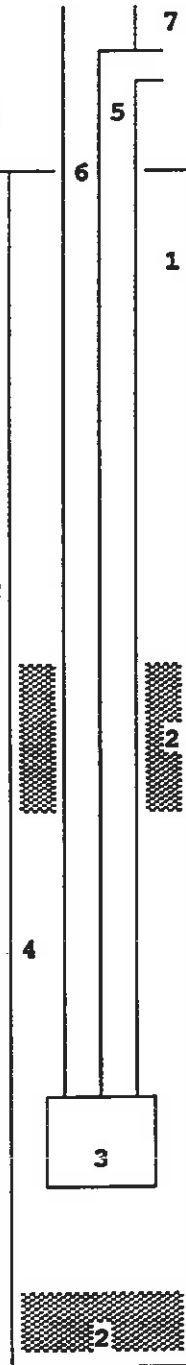

CEMENTED BENTONITE SEAL FROM
 824.61 TO BOTTOM OF CONCRETE
 PAD.

TOP OF BENTONITE SEAL 824.61

TOP OF GRAVEL PACK 815.21

CHECK VALVE 709.61
 TOP OF SCREEN 709.01

BOTTOM OF SCREEN 705.01

BOTTOM OF GRAVEL PACK 703.61

BOTTOM OF BORE HOLE 642.61

GEOTECHNICAL ENGINEERING SECTION
 CIVIL ENGINEERING DESIGN

AMERICAN ELECTRIC POWER SERVICE CORPORATION

GEOMON
 WELL

CDS-04C

COMPANY MOUNTAINNEER PLANT
 PROJECT ASH LANDFILL
 COORDINATES N.709,726.78 E.1,731,757.61
 DATE INSTALLED 7-25-86
 LATITUDE N.38 56 43.00
 LONGITUDE W. 81 56 35.09

WELL CONSTRUCTION
 SUMMARY ELEVATION
 (ft. NGVD)
 WELL NO. MW-2
 REF. DATUM PT. 856.35
 GRADE 854.61

NOTE: CASING PROTECTOR DETAILS
 NOT SHOWN

- 1 GROUT SEAL SEE MW-1
- 2 BENTONITE SEAL
- 3 GEOMON UNIT 1.25 POLETHYLENE
- 4 GRAVEL PACK CONCRETE SAND
- 5 CONTINUOUS UNKINKED NYLON TUBING EXTENDED TO TOP OF CHECK VALVE
- 6 CASING 3/4" DIA. SCH. 80 PVC
- 7 BRASS 'Y'FITTING

MW-1 & MW-2 NESTED IN SAME
 3" DIAMETER HOLE.

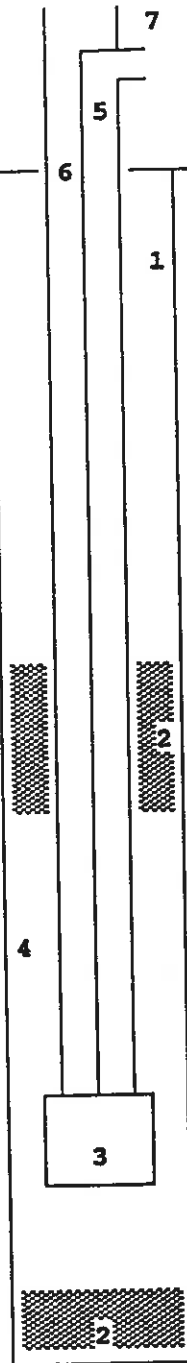

NOTE: SEE WELL LOG MW-1 FOR
 REMAINING PORTION OF HOLE.

TOP OF BENTONITE SEAL 703.61

TOP OF GRAVEL PACK 685.71

CHECK VALVE 652.91
 TOP OF SCREEN 652.31

BOTTOM OF SCREEN 648.31

BOTTOM OF GRAVEL PACK 642.61

BOTTOM OF BORE HOLE 580.61

GEOTECHNICAL ENGINEERING SECTION
 CIVIL ENGINEERING DESIGN

AMERICAN ELECTRIC POWER SERVICE CORPORATION

GEOMON
 WELL

CDS-04C

COMPANY MOUNTAINNEER PLANT
 PROJECT ASH LANDFILL
 COORDINATES N.709,173.32 E.1,728,977.06
 DATE INSTALLED 7-21-86
 LATITUDE N.38 56 37.25
 LONGITUDE W.81 57 09.95

WELL CONSTRUCTION
 SUMMARY ELEVATION
 (ft. NGVD)
 WELL NO. MW-3
 REF. DATUM PT. 857.56
 GRADE 855.56

NOTE: CASING PROTECTOR DETAILS NOT SHOWN

- 1 GROUT SEAL CEMENTED/BENTONITE
 - 2 BENTONITE SEAL
 - 3 GEOMON UNIT 1.25 POLYETHYLENE
 - 4 GRAVEL PACK CONCRETE SAND
 - 5 CONTINUOUS UNKINKED NYLON TUBING EXTENDED TO TOP OF CHECK VALVE
 - 6 CASING 3/4" DIA. SCH. 80 PVC
 - 7 BRASS 'Y' FITTING
- BOREING DIAMETER 3"
 BENTONITE SEAL 705.16 TO 595.56

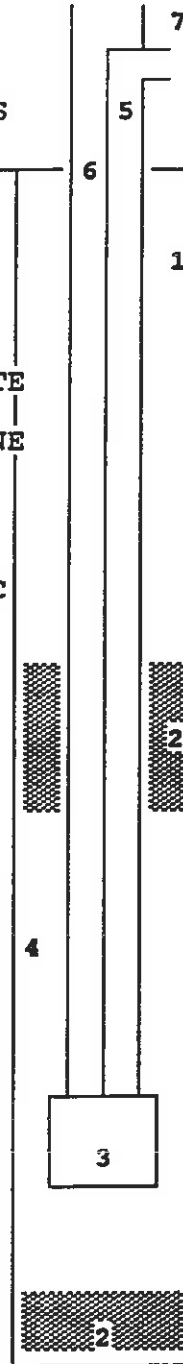

CEMENT BENTONITE SEAL FROM 820.86 TO BOTTOM OF CONCRETE PAD.

TOP OF BENTONITE SEAL 820.86

TOP OF GRAVEL PACK 816.26

CHECK VALVE 712.96
TOP OF SCREEN 712.36

BOTTOM OF SCREEN 708.36

BOTTOM OF GRAVEL PACK 705.16

BOTTOM OF BORE HOLE 595.56

GEOTECHNICAL ENGINEERING SECTION
 CIVIL ENGINEERING DESIGN

AMERICAN ELECTRIC POWER SERVICE CORPORATION

GEOMON
 WELL

CDS-04C

COMPANY MOUNTAINNEER PLANT
 PROJECT ASH LANDFILL
 COORDINATES N.710,357.00.E.1,731,153.00
 DATE INSTALLED 7-21-86
 LATITUDE N.38 56 49.17
 LONGITUDE W.81 56 42.82

WELL CONSTRUCTION
 SUMMARY ELEVATION
 (ft. NGVD)
 WELL NO. MW-4
 REF. DATUM PT. 803.44
 GRADE 802.08

NOTE: CASING PROTECTOR DETAILS
 NOT SHOWN

- 1 GROUT SEAL CEMENT BENTONITE
- 2 BENTONITE SEAL
- 3 GEOMON UNIT 1.25 POLYETHYENE
- 4 GRAVEL PACK CONCRETE SAND
- 5 CONTINUOUS UNKINKED NYLON TUBING EXTENDED TO TOP OF CHECK VALVE
- 6 CASING 3/4" DIA. SCH. 80 PVC
- 7 BRASS 'Y' FITTING BORE HOLE 3" DIA.

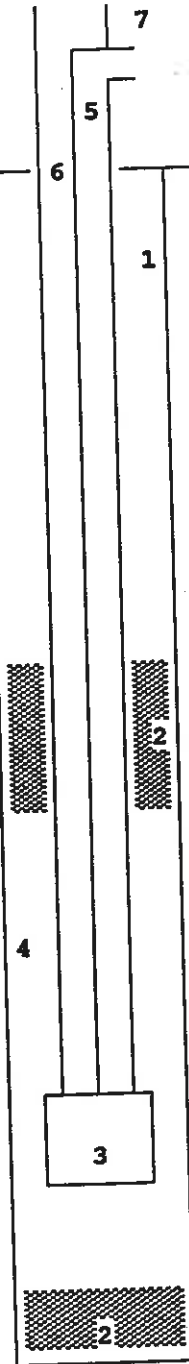

CEMENT BENTONITE SEAL FROM
 782.38 TO BOTTOM OF CONCRETE
 PAD.

TOP OF BENTONITE SEAL 782.38

TOP OF GRAVEL PACK 777.08

CHECK VALVE 707.68
 TOP OF SCREEN 707.08

BOTTOM OF SCREEN 703.08

BOTTOM OF GRAVEL PACK 702.38

BOTTOM OF BORE HOLE 702.38

GEOTECHNICAL ENGINEERING SECTION
 CIVIL ENGINEERING DESIGN

AMERICAN ELECTRIC POWER SERVICE CORPORATION

GEOMON
 WELL '
 CDS-04C

COMPANY MOUNTAINEER PLANT
 PROJECT ASH LANDFILL
 COORDINATES N.711462.71 E.1728597.82
 DATE INSTALLED 6-23-92
 LATITUDE 38 56 59.84041
 LONGITUDE 81 57 15.30527

**WELL CONSTRUCTION
 SUMMARY ELEVATION
 (ft. NGVD)**
 WELL NO. MW-5
 REF. DATUM PT. 791.45
 GRADE 788.93

NOTE: CASING PROTECTOR DETAILS NOT SHOWN

- 1 GROUT SEAL VOLCLAY GROUT
 - 2 BENTONITE SEAL
 - 3 GEOMON UNIT 1.25 DIA. 20 SLOT SCREEN
 - 4 GRAVEL PACK #4 OHIO QUARTZ
 - 5 CONTINUOUS UNKINKED NYLON TUBING EXTENDED TO TOP OF CHECK VALVE
 - 6 CASING 1" DIA. SCH. 80 PVC
 - 7 BRASS 'Y' FITTING
- BENTONITE PELLETS FROM 738.73 TO 698.93 EMPLACED BY TREMIE PIPE.
 3" DIA. BORE HOLE.

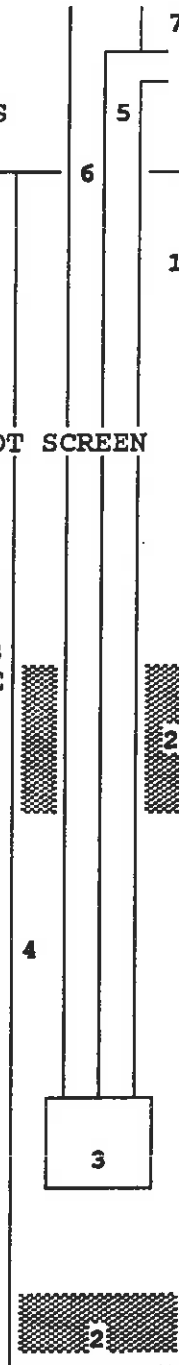

VOLCLAY GROUT FROM 764.63 TO BOTTOM OF CONCRETE PAD.

TOP OF BENTONITE SEAL 764.63

TOP OF GRAVEL PACK 759.73

CHECK VALVE 742.73
 TOP OF SCREEN 742.13
 BOTTOM OF SCREEN 740.13
 GEOMON TIP 739.73

BOTTOM OF GRAVEL PACK 738.73

BOTTOM OF BORE HOLE 698.93

GEOTECHNICAL ENGINEERING SECTION
 CIVIL ENGINEERING DESIGN

AMERICAN ELECTRIC POWER SERVICE CORPORATION

GEOMON
 WELL

CDS-04C

MW-6 2" well

Ground concrete will
be placed AFTER
construction

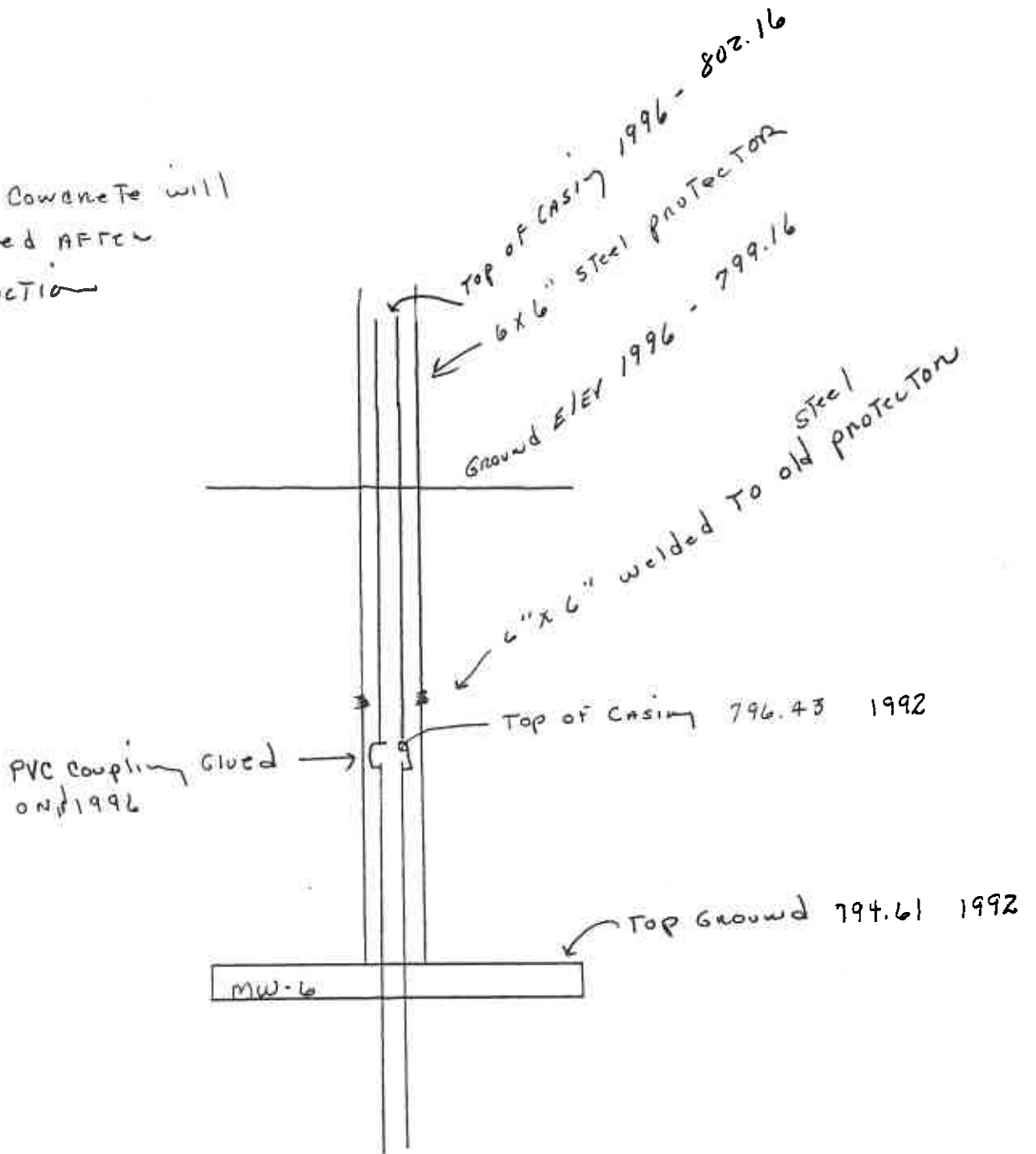

COMPANY APCO MOUNTAINEER PLANT
 PROJECT ASH LANDFILL
 COORDINATES N.712003.88 E.1729676.15
 DATE INSTALLED 6-16-92
 LATITUDE 38 57 05.29684
 LONGITUDE 81 57 01.72920
 NOTE: CASING PROTECTOR DETAILS
 NOT SHOWN

WELL CONSTRUCTION
 SUMMARY ELEVATION
 (ft. NGVD)
 WELL NO. MW-6
 REF. DATUM PT. 796.43
 GRADE 794.61

- 1 GROUT SEAL VALCLAY GROUT
- 2 BENTONITE SEAL PELLETS SEAL
- 3 SCREEN 20 SLOT SIZE 2" DIA.
- 4 GRAVEL PACK #4 OHIO QUARTZ
- 5 N.A.
- 6 RISER PIPE 2" DIA. SCH. 40
 6-15-92 BAILED HOLE DRY.
 6-16-92 SWL 663.71
 6-16-92 AFTER INSTALLATION
 BAILED WELL TO 664.61
 BORE HOLE 6" DIAMETER

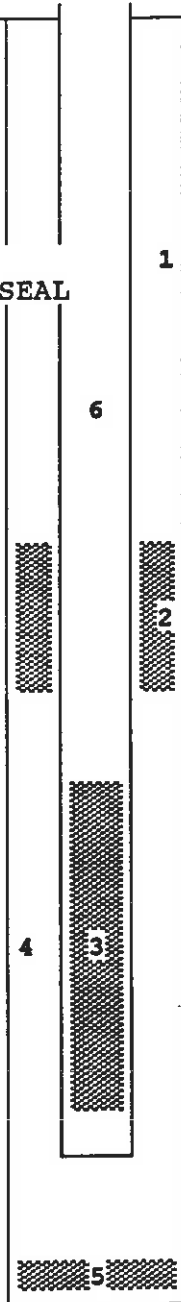

VOLCLAY GROUT FROM 675.41
TO BOTTOM OF CONCRETE PAD.

TOP OF BENTONITE SEAL 675.41

TOP OF GRAVEL PACK 670.11

TOP OF SCREEN 668.81

BOTTOM OF SCREEN 659.81

BOTTOM OF BLANK SECTION 658.91

BOTTOM OF GRAVEL PACK 657.61

BOTTOM OF BORE HOLE 654.61

GEOTECHNICAL ENGINEERING SECTION
 CIVIL ENGINEERING DESIGN

AMERICAN ELECTRIC POWER SERVICE CORPORATION

OBSERVATION
 WELL

CDS-04

MW-07 1" well

Ground concrete will
be placed AFTER
CONSTRUCTION

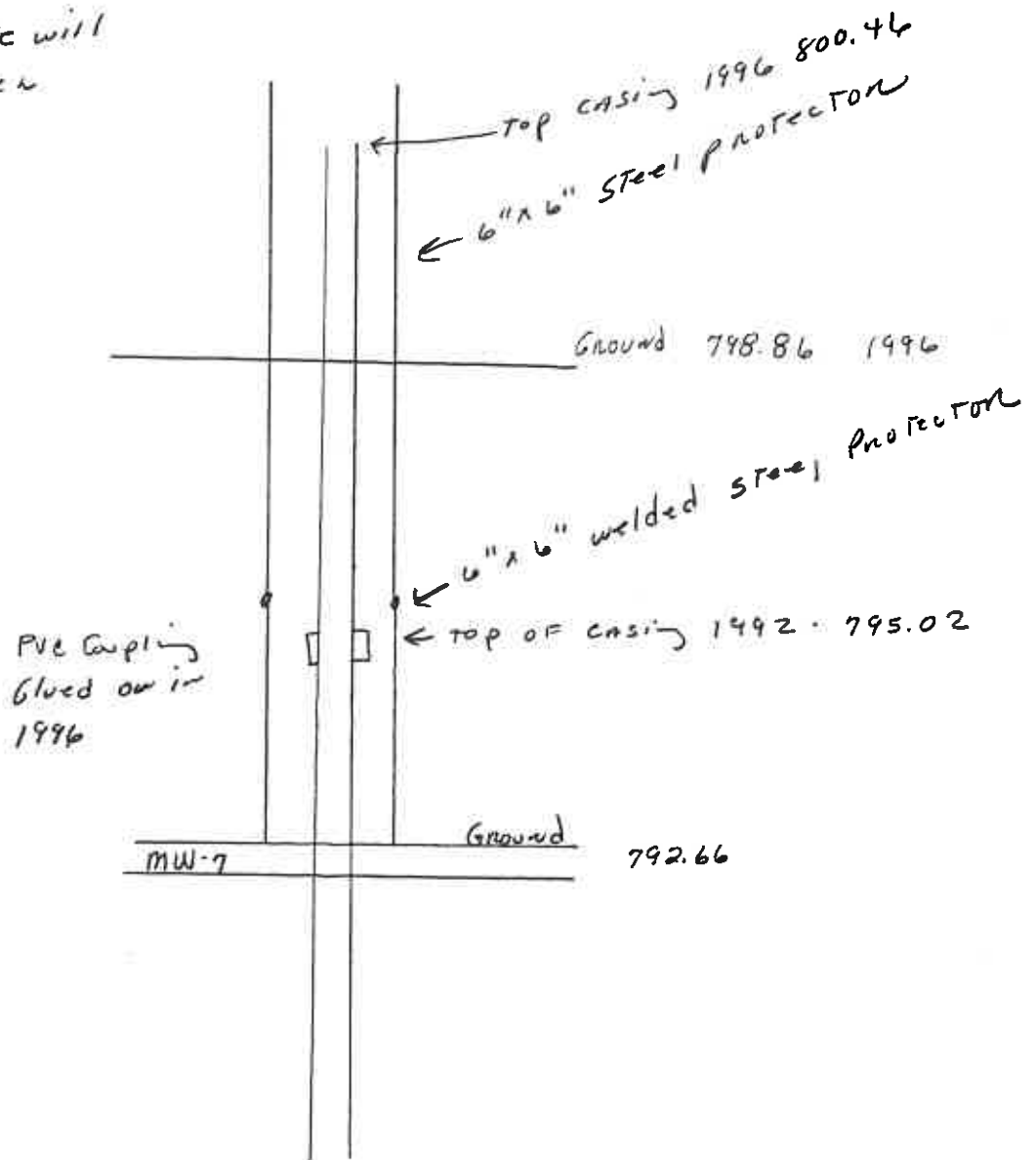

COMPANY MOUNTAINEER PLANT.
 PROJECT ASH LANDFILL
 COORDINATES N.711982.06 E.1729623.07
 DATE INSTALLED 6-1-92
 LATITUDE 38 57 05.07624
 LONGITUDE 81 57 02.39998

WELL CONSTRUCTION
 SUMMARY ELEVATION
 (ft. NGVD)
 WELL NO. MW-7
 REF. DATUM PT. 795.02
 GRADE 792.66

NOTE: CASING PROTECTOR DETAILS
 NOT SHOWN

- 1 GROUT SEAL VOLCLAY GROUT
- 2 BENTONITE SEAL BENTONITE
- 3 GEOMON UNIT 1.25 DIA. 20 SLOT SCREEN
- 4 GRAVEL PACK #4 OHIO QUARTZ
- 5 CONTINUOUS UNKINKED NYLON TUBING EXTENDED TO TOP OF CHECK VALVE
- 6 CASING 1"DIA. SCH.80 PVC
- 7 BRASS 'Y'FITTING SWL 762.46 PRIOR TO INSTALLATION.

BORE HOLE DIAMETER 3"

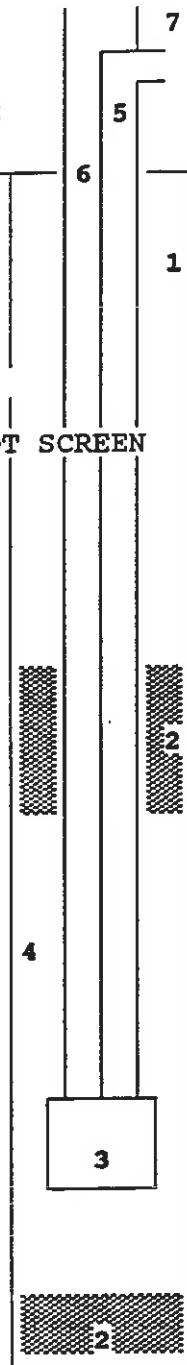

VOLCLAY GROUT FROM 768.66 TO
 BOTTOM OF CONCRETE PAD.

TOP OF BENTONITE SEAL 768.86

TOP OF GRAVEL PACK 762.86

CHECK VALVE 740.06

TOP OF SCREEN 739.46

BOTTOM OF SCREEN 737.46

GEOMON TIP 737.06

BOTTOM OF GRAVEL PACK 735.66

BOTTOM OF BORE HOLE 701.66

GEOTECHNICAL ENGINEERING SECTION
 CIVIL ENGINEERING DESIGN

AMERICAN ELECTRIC POWER SERVICE CORPORATION

GEOMON
 WELL

CDS-04C

COMPANY APCO MOUNTAINEER PLANT
 PROJECT ASH LANDFILL
 COORDINATES N.710780.86 E.1730856.45
 DATE INSTALLED 7-29-92
 LATITUDE 38 56 53.33134
 LONGITUDE 81 56 46.63136
 NOTE: CASING PROTECTOR DETAILS
 NOT SHOWN

WELL CONSTRUCTION
 SUMMARY ELEVATION
 (ft. NGVD)
 WELL NO. MW-8
 REF. DATUM PT. 677.23
 GRADE 675.49

- 1 GROUT SEAL VOLCLAY GROUT
- 2 BENTONITE SEAL BENTONITE
- 3 SCREEN 2" DIA. 20 SLOT SCREEN
GRAVEL PACK #4 OHIO QUARTZ
- 5 N.A.
- 6 RISER PIPE 2"DIA SCH 40 PVC

BAILED WATER FROM COMPLETED
 WELL. WATER LEVEL WOULD
 NOT DROP BELOW 663.49
 ELEVATION. RECOVERED TO
 669.49 ELEVATION WITH IN
 MINUTES.

BORE HOLE 6"DIAMETER
 BENTONITE PELLETS EMPLACED
 THROUGH TREMIE PIPE FROM
 620.49 TO 570.79.

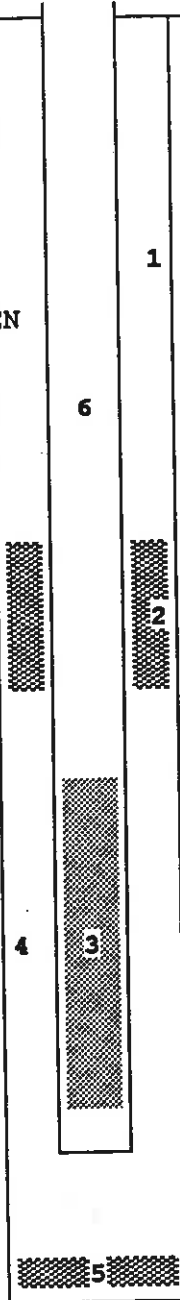

VOLCLAY GROUT FROM 638.89
 TO BOTTOM OF CONCRETE PAD.

TOP OF BENTONITE SEAL 638.89

TOP OF GRAVEL PACK 632.89

TOP OF SCREEN 631.49

BOTTOM OF SCREEN 622.59

BOTTOM OF BLANK SECTION 621.49

BOTTOM OF GRAVEL PACK 620.49

BOTTOM OF BORE HOLE 570.79

GEOTECHNICAL ENGINEERING SECTION
 CIVIL ENGINEERING DESIGN

AMERICAN ELECTRIC POWER SERVICE CORPORATION

OBSERVATION
 WELL

CDS-04

COMPANY APCO MOUNTAINEER PLANT
 PROJECT ASH LANDFILL
 COORDINATES N.712268.45 E.1732217.43
 DATE INSTALLED 8-6-92
 LATITUDE 38 57 08.17104
 LONGITUDE 81 56 29.59950
 NOTE: CASING PROTECTOR DETAILS
 NOT SHOWN

WELL CONSTRUCTION
 SUMMARY ELEVATION
 (ft. NGVD)
 WELL NO. MW-9
 REF. DATUM PT. 644.9
 GRADE 643.0

- 1 GROUT SEAL VOLCLAY GROUT
- 2 BENTONITE SEAL
- 3 SCREEN 2"DIA 20 SLOT SCREEN
- 4 GRAVEL PACK #4 OHIO QUARTZ
- 5 N.A.
- 6 RISER PIPE 2" DIA. SCH. 40

BAILED WELL AFTER
 INSTALLATION SWL RECOVERED
 TO APPROX. 6 FT. FROM
 GRADE.
 BORE HOLE 6" DIAMETER

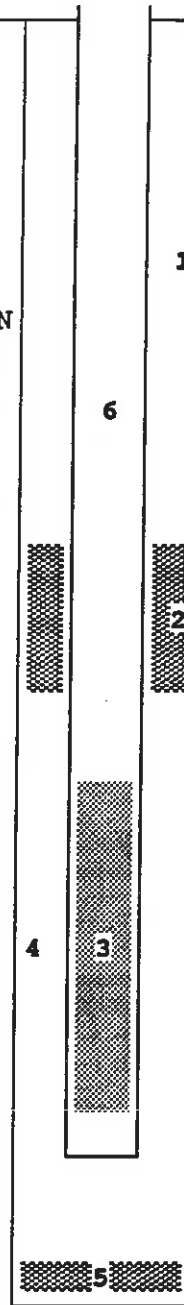

- 1 VOLCLAY GROUT FROM 607.0 TO
BOTTOM OF CONCRETE PAD.

TOP OF BENTONITE SEAL 607.0

TOP OF GRAVEL PACK 600.1

TOP OF SCREEN 599.2

BOTTOM OF SCREEN 590.1

BOTTOM OF BLANK SECTION 589.0

BOTTOM OF GRAVEL PACK 587.7

BOTTOM OF BORE HOLE 587.7

GEOTECHNICAL ENGINEERING SECTION
 CIVIL ENGINEERING DESIGN

AMERICAN ELECTRIC POWER SERVICE CORPORATION

OBSERVATION
 WELL

CDS-04

COMPANY MOUNTAINEER PLANT
 PROJECT ASH LANDFILL
 COORDINATES 710968.64 E.1730231.83
 DATE INSTALLED 7-9-92
 LATITUDE 38 56 55.12112
 LONGITUDE 81 57 54.56506

WELL CONSTRUCTION
 SUMMARY ELEVATION
 (ft. NGVD)
 WELL NO. MW-10
 REF. DATUM PT. 813.07
 GRADE 810.83

NOTE: CASING PROTECTOR DETAILS
 NOT SHOWN

- 1 GROUT SEAL VOLCLAY GROUT
- 2 BENTONITE SEAL PELLETS
- 3 GEOMON UNIT 1.25 DIA. 20 SLOT
- 4 GRAVEL PACK #4 OHIO QUARTZ
- 5 CONTINUOUS UNKINKED NYLON TUBING EXTENDED TO TOP OF CHECK VALVE
- 6 CASING 1" SCH. 80 PVC
- 7 BRASS 'Y' FITTING

SWL 773.63 PRIOR TO
 INSTALLATION.

6" DIA BORE HOLE
 WELLS MW-10 AND MW-11 NESTED
 IN THE SAME HOLE.

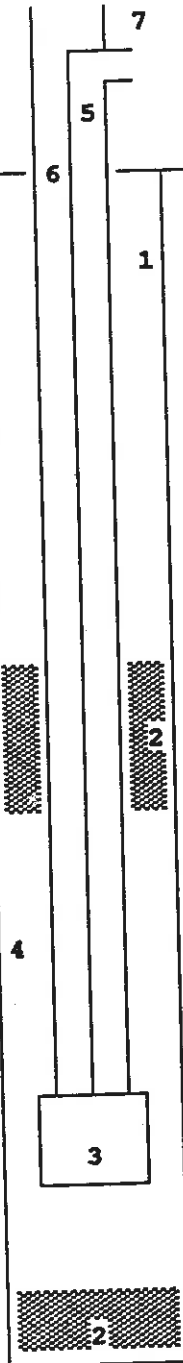

VOLCLAY GROUT FROM 747.33 TO
 BOTTOM OF CONCRETE PAD.

TOP OF BENTONITE SEAL 747.33

TOP OF GRAVEL PACK 739.53

CHECK VALVE 724.33
 TOP OF SCREEN 723.73
 BOTTOM OF SCREEN 721.73
 GEOMON TIP 721.33

BOTTOM OF GRAVEL PACK 718.73

BOTTOM OF BORE HOLE 658.63

GEOTECHNICAL ENGINEERING SECTION
 CIVIL ENGINEERING DESIGN

AMERICAN ELECTRIC POWER SERVICE CORPORATION

GEOMON
 WELL

CDS-04C

COMPANY APCO MOUNTAINEER PLANT
 PROJECT ASH LANDFILL
 COORDINATES N.710968.29 E.1730231.77
 DATE INSTALLED 7-8-922
 LATITUDE 38 56 55.12004
 LONGITUDE 81 56 54.56455
 NOTE: CASING PROTECTOR DETAILS
 NOT SHOWN

WELL CONSTRUCTION
 SUMMARY ELEVATION
 (ft. NGVD)
 WELL NO. MW-11
 REF. DATUM PT. 813.63
 GRADE 810.83

- 1 GROUT SEAL BENTONITE PELLETS
- 2 BENTONITE SEAL
- 3 SCREEN 2"DIA. 20 SLOT PVC
- 4 GRAVEL PACK #4 OHIO QUARTZ
- 5 N.A.
- 6 RISER PIPE 2" DIA SCH. 40 PVC

SWL BAILED HOLE DRY PRIOR TO INSTALLATION.

MW-10 AND MW-11 NESTED IN THE SAME 6" DIA HOLE.

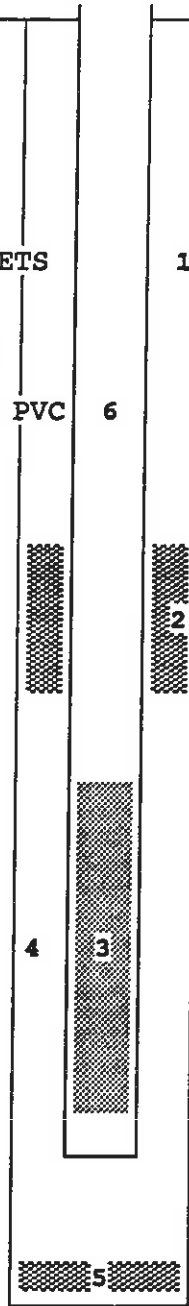

1 BENTONITE PELLETS FROM 673.83 TO 718.13.

TOP OF BENTONITE SEAL 718.73

TOP OF GRAVEL PACK 673.83

TOP OF SCREEN 670.93

BOTTOM OF SCREEN 661.93

BOTTOM OF BLANK SECTION 660.83

BOTTOM OF GRAVEL PACK 659.83

BOTTOM OF BORE HOLE 658.63

GEOTECHNICAL ENGINEERING SECTION
 CIVIL ENGINEERING DESIGN

AMERICAN ELECTRIC POWER SERVICE CORPORATION

OBSERVATION
 WELL

CDS-04

COMPANY APCO MOUNTAINTEES PLANT
 PROJECT LANDFILL
 COORDINATES N.709162.51 E.1728963.47
 DATE INSTALLED 5-6-92
 LATITUDE 38 56 37.14206
 LONGITUDE 81 57 10.38134

WELL CONSTRUCTION
 SUMMARY ELEVATION
 (ft. NGVD)
 WELL NO. MW12
 REF. DATUM PT. 858.85
 GRADE 856.93

NOTE: CASING PROTECTOR DETAILS
 NOT SHOWN

- 1 GROUT SEAL VOLCLAY GROUT
- 2 BENTONITE SEAL PELLETS
- 3 GEOMON UNIT 1.25 DIA. 20 SLOT
- 4 GRAVEL PACK #4 OHIO QUARTZ
- 5 CONTINUOUS UNKINKED NYLON TUBING EXTENDED TO TOP OF CHECK VALVE
- 6 CASING 1" DIA SCH. 80 PVC.
- 7 BRASS 'Y' FITTING

SWL PRIOR TO INSTALLATION 8FT.
 HOLE BAILED DRY PRIOR TO
 INSTALLATION.

UNIT PURGED AFTER INSTALLATION
 SWL NOT NOTED SINCE THIS
 WATER IS DISPLACED BY WELL.

BORING DIAMETER 3"

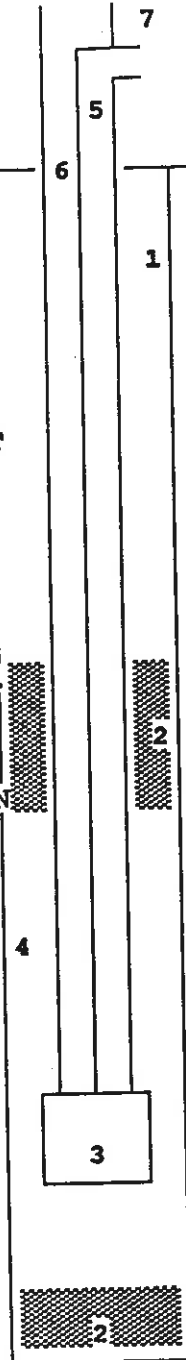

VOLCLAY GROUT FROM 690.93 TO
 BOTTOM OF CONCRETE PAD.

TOP OF BENTONITE SEAL 690.93

TOP OF GRAVEL PACK 684.93

CHECK VALVE 666.93
 TOP OF SCREEN 666.33
 BOTTOM OF SCREEN 664.33
 GEOMON TIP 663.93

BOTTOM OF GRAVEL PACK 662.93

BOTTOM OF BORE HOLE 656.63

GEOTECHNICAL ENGINEERING SECTION
 CIVIL ENGINEERING DESIGN

AMERICAN ELECTRIC POWER SERVICE CORPORATION

GEOMON
 WELL

CDS-04C

COMPANY APCO MOUNTAINTAINTER PLANT
 PROJECT LANDFILL
 COORDINATES N.710337.36 E.1731154.1
 DATE INSTALLED 5-14-92
 LATITUDE 38 56 48.97734
 LONGITUDE 81 56 42.79826

WELL CONSTRUCTION
 SUMMARY ELEVATION
 (ft. NGVD)
 WELL NO. MW-13
 REF. DATUM PT. 805.05
 GRADE 802.01

NOTE: CASING PROTECTOR DETAILS
 NOT SHOWN

- 1 GROUT SEAL VOLCLAY GROUT
- 2 BENTONITE SEAL PELLETS
- 3 GEOMON UNIT 1.25 DIA 20 SLOT
- 4 GRAVEL PACK #4 OHIO QUARTZ
- 5 CONTINUOUS UNKINKED NYLON TUBING EXTENDED TO TOP OF CHECK VALVE
- 6 CASING 1" DIA. SCH. 80 PVC
- 7 BRASS 'Y' FITTING

BORE HOLE DIAMETER 3".

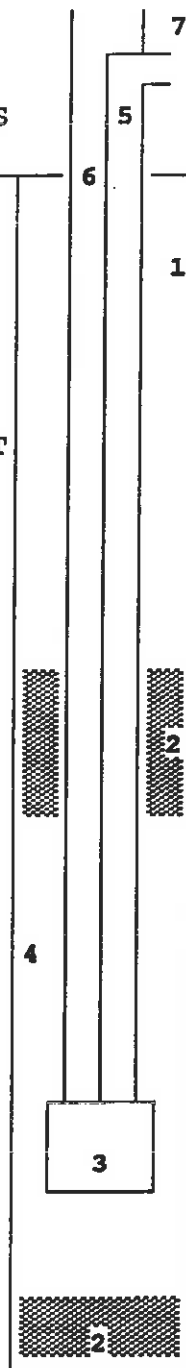

VOLCLAY GROUT FROM 674.01 TO
 BOTTOM OF CONCRETE PAD.

TOP OF BENTONITE SEAL 674.01

TOP OF GRAVEL PACK 668.51

CHECK VALVE 651.21
 TOP OF SCREEN 650.61
 BOTTOM OF SCREEN 648.61
 GEOMON TIP 648.21

BOTTOM OF GRAVEL PACK 647.01

BOTTOM OF BORE HOLE 647.01

GEOTECHNICAL ENGINEERING SECTION
 CIVIL ENGINEERING DESIGN

AMERICAN ELECTRIC POWER SERVICE CORPORATION

GEOMON,
 WELL

CDS-04C

COMPANY APCO MOUNTAINEER PLANT
 PROJECT ASH LANDFILL
 COORDINATES N.710272.6 E.1729225.46
 DATE INSTALLED 8-11-92
 LATITUDE 38 56 48.14330
 LONGITUDE 81 57 07.20934

NOTE: CASING PROTECTOR DETAILS
 NOT SHOWN

WELL CONSTRUCTION
 SUMMARY ELEVATION
 (ft. NGVD)
 WELL NO. MW-14
 REF. DATUM PT. 716.87
 GRADE 715.1

- 1 GROUT SEAL VOLCLAY
- 2 BENTONITE SEAL PELLETS
- 3 SCREEN 2" DIA. 20 SLOT PVC
- 4 GRAVEL PACK #4 OHIO QUARTZ
- 5 N.A.
- 6 RISER PIPE 2" DIA. SCH 40 PVC

WELL BAILED DRY AFTER
 INSTALLATION.

BOREHOLE DIAMETER 6"

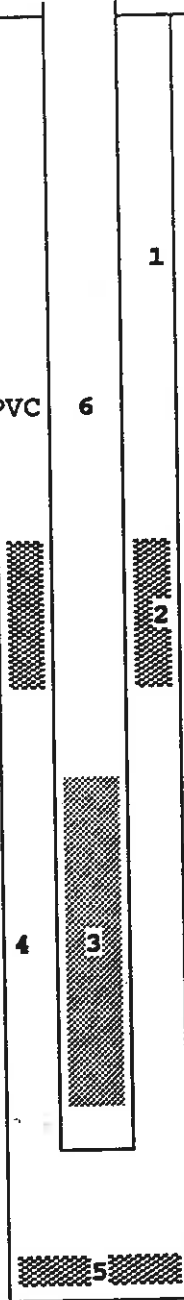

VOLCLAY GROUT FROM 676.9 TO
 BOTTOM OF CONCRETE PAD.

TOP OF BENTONITE SEAL 676.9

TOP OF GRAVEL PACK 671.1

TOP OF SCREEN 669.7

BOTTOM OF SCREEN 660.2

BOTTOM OF BLANK SECTION 659.7

BOTTOM OF GRAVEL PACK 658.7

BOTTOM OF BORE HOLE 658.7

GEOTECHNICAL ENGINEERING SECTION
 CIVIL ENGINEERING DESIGN

AMERICAN ELECTRIC POWER SERVICE CORPORATION

OBSERVATION
 WELL

CDS-04

COMPANY APCO MOUNTAINEER PLANT
 PROJECT ASH LANDFILL
 COORDINATES N.710943.81 E.1730886.18
 DATE INSTALLED 7-22-92
 LATITUDE 38 56 54.94387
 LONGITUDE 81 56 46.27894
 NOTE: CASING PROTECTOR DETAILS
 NOT SHOWN

WELL CONSTRUCTION
 SUMMARY ELEVATION
 (ft. NGVD)
 WELL NO. MW-15
 REF. DATUM PT. 681.2
 GRADE 679.29

- 1 GROUT SEAL VOLCLAY GROUT
- 2 BENTONITE SEAL PELLETS
- 3 SCREEN 2" DIA. 20 SLOT PVC
- 4 GRAVEL PACK #4 OHIO QUARTZ
- 5 N.A.
- 6 RISER PIPE 2" DIA. SCH. 40 PVC BORE HOLE 6"

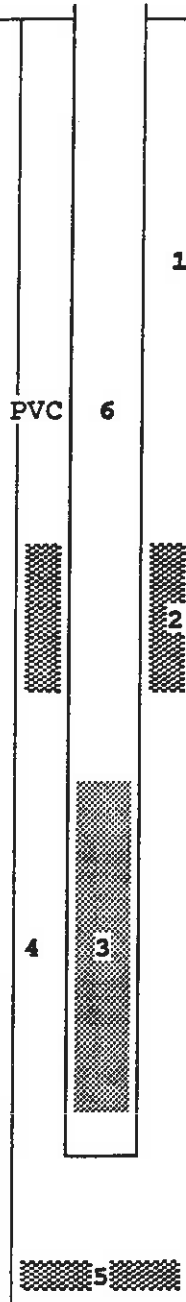

VOLCLAY GROUT FROM 640.59 TO BOTTOM OF CONCRETE PAD.

TOP OF BENTONITE SEAL 640.59

TOP OF GRAVEL PACK 635.59

TOP OF SCREEN 634.39

BOTTOM OF SCREEN 625.39

BOTTOM OF BLANK SECTION 624.29

BOTTOM OF GRAVEL PACK 623.29

BOTTOM OF BORE HOLE 621.19

GEOTECHNICAL ENGINEERING SECTION
 CIVIL ENGINEERING DESIGN

AMERICAN ELECTRIC POWER SERVICE CORPORATION

OBSERVATION
 WELL

CDS-04

COMPANY APCO MOUNTAINEER PLANT
 PROJECT ASH LANDFILL
 COORDINATES N.714546.94 E.1733259.19
 DATE INSTALLED 5-21-92
 LATITUDE 38 57 30.79416
 LONGITUDE 81 56 16.70491

WELL CONSTRUCTION
 SUMMARY ELEVATION
 (ft. NGVD)
 WELL NO. MW-16
 REF. DATUM PT. 628.78
 GRADE 626.03

NOTE: CASING PROTECTOR DETAILS
 NOT SHOWN

- 1 GROUT SEAL VOLCLAY GROUT
- 2 BENTONITE SEAL PELLETS
- 3 SCREEN 2" DIA. 20 SLOT PVC
- 4 GRAVEL PACK #4 OHIO QUARTZ
- 5 N.A.
- 6 RISER PIPE 2" DIA. SCH. 40

BORE HOLE 6"

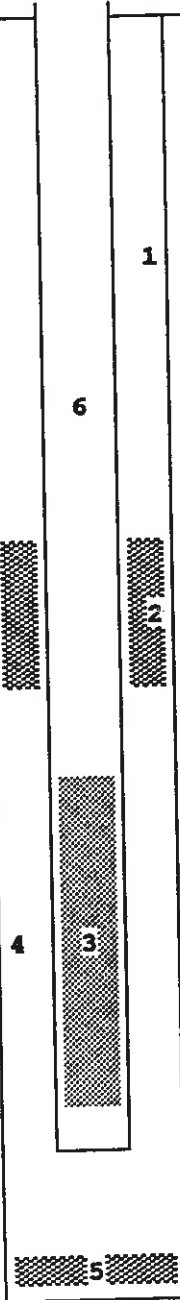

BENTONITE PELLETS FROM 621.03
 TO BOTTOM OF CONCRETE PAD.
 BENTONITE PELLETS WERE HYDRATED
 DURING INSTALLATION.

TOP OF BENTONITE SEAL 621.03

TOP OF GRAVEL PACK 616.03

TOP OF SCREEN 615.03

BOTTOM OF SCREEN 604.58

BOTTOM OF BLANK SECTION 604.03

BOTTOM OF GRAVEL PACK 597.53

BOTTOM OF BORE HOLE 597.53

GEOTECHNICAL ENGINEERING SECTION
 CIVIL ENGINEERING DESIGN

OBSERVATION
 WELL

AMERICAN ELECTRIC POWER SERVICE CORPORATION

CDS-04

COMPANY APCO MOUNTAINEER PLANT
 PROJECT ASH LANDFILL
 COORDINATES N.714833.45 E.1733260.67
 DATE INSTALLED 5-20-92
 LATITUDE 38 57 33.62858
 LONGITUDE 81 56 16.72503
 NOTE: CASING PROTECTOR DETAILS
 NOT SHOWN

WELL CONSTRUCTION
 SUMMARY ELEVATION
 (ft. NGVD)
 WELL NO. MW-17
 REF. DATUM PT. 623.29
 GRADE 621.47

- 1 GROUT SEAL VOLCLAY GROUT
- 2 BENTONITE SEAL PELLETS
- 3 SCREEN 2" DIA. 20 SLOT PVC
- 4 GRAVEL PACK #4 OHIO QUARTZ
- 5 N.A.
- 6 RISER PIPE 2" DIA. SCH. 40 PVC

BORE HOLE DIAMETER 6"

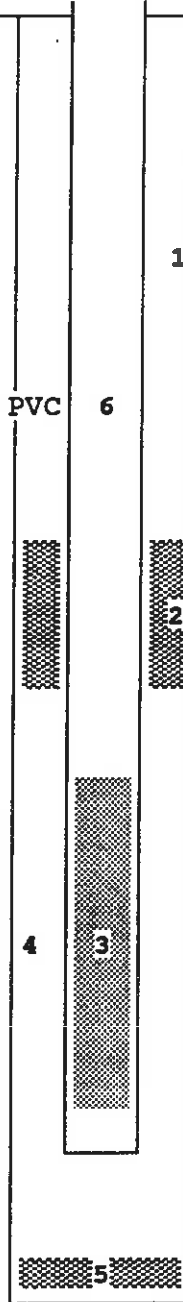

VOLCLAY GROUT TO BOTTOM OF CONCRETE PAD.

TOP OF BENTONITE SEAL 609.47

TOP OF GRAVEL PACK 604.47

TOP OF SCREEN 602.92

BOTTOM OF SCREEN 593.47

BOTTOM OF BLANK SECTION 592.47

BOTTOM OF GRAVEL PACK 590.97

BOTTOM OF BORE HOLE 590.97

GEOTECHNICAL ENGINEERING SECTION
 CIVIL ENGINEERING DESIGN
 AMERICAN ELECTRIC POWER SERVICE CORPORATION

OBSERVATION
 WELL
 CDS-04

COMPANY APCO MOUNTAINEER PLANT
 PROJECT ASH LANDFILL
 COORDINATES N.714922.00 E.1733257.86
 DATE INSTALLED 5-19-92
 LATITUDE 38 57 34.50337
 LONGITUDE 81 56 16.77161
 NOTE: CASING PROTECTOR DETAILS
 NOT SHOWN

WELL CONSTRUCTION
 SUMMARY ELEVATION
 (ft. NGVD)
 WELL NO. MW-18
 REF. DATUM PT. 623.78
 GRADE 621.95

- 1 GROUT SEAL VOLCLAY GROUT
- 2 BENTONITE SEAL PELLETS
- 3 SCREEN 2" DIA. 20 SLOT PVC
- 4 GRAVEL PACK #4 OHIO QUARTZ
- 5 N.A.
- 6 RISER PIPE 2" DIA. SCH. 40 PVC

SWL PRIOR TO INSTALLATION
 608.65
 BAILED TO 20.0 DURING
 INSTALLATION.

BORE HOLE DIAMETER 6"

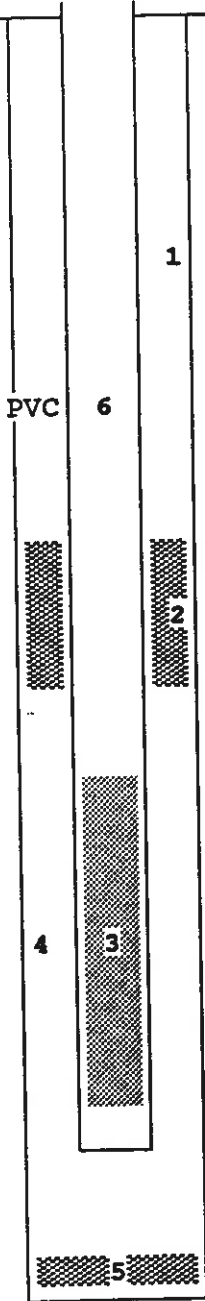

VOLCLAY GROUT FROM 612.95 TO
BOTTOM OF CONCRETE PAD.

TOP OF BENTONITE SEAL 612.95

TOP OF GRAVEL PACK 608.15

TOP OF SCREEN 606.85

BOTTOM OF SCREEN 597.75

BOTTOM OF BLANK SECTION 596.75

BOTTOM OF GRAVEL PACK 595.75

BOTTOM OF BORE HOLE 595.75

GEOTECHNICAL ENGINEERING SECTION
 CIVIL ENGINEERING DESIGN

AMERICAN ELECTRIC POWER SERVICE CORPORATION

OBSERVATION
 WELL

CDS-04

COMPANY APCO MOUNTAINEER PLANT
 PROJECT ASH LANDFILL
 COORDINATES N.712263.69 E.1732224.97
 DATE INSTALLED 8-13-92
 LATITUDE 38 57 08.12124
 LONGITUDE 81 56 29.50359
 NOTE: CASING PROTECTOR DETAILS
 NOT SHOWN

WELL CONSTRUCTION
 SUMMARY ELEVATION
 (ft. NGVD)
 WELL NO. MW-19
 REF. DATUM PT. 645.14
 GRADE 643.18

- 1 GROUT SEAL BENTONITE PELLETS
- 2 BENTONITE SEAL PELLETS
- 3 SCREEN 2" DIA. 20 SLOT PVC.
- 4 GRAVEL PACK #4 OHIO QUARTZ
- 5 N.A.
- 6 RISER PIPE 2" DIA. SCH. 40 PVC

BORE HOLE DIAMETER 6"
 CLUSTERED WELL SITE WITH
 MW-9.

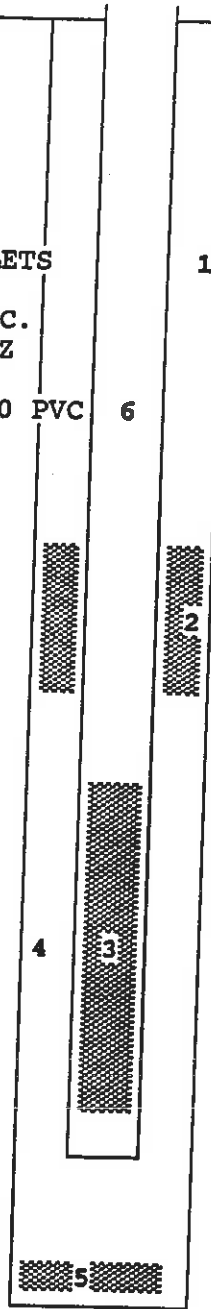

TOP OF BENTONITE SEAL BOTTOM
 OF CONCRETE PAD. PELLETS WERE
 HYDRATED DURING INSTALLATION.

TOP OF GRAVEL PACK 632.68

TOP OF SCREEN 631.58

BOTTOM OF SCREEN 622.68

BOTTOM OF BLANK SECTION 621.58

BOTTOM OF GRAVEL PACK 620.38

BOTTOM OF BORE HOLE 620.38

GEOTECHNICAL ENGINEERING SECTION
 CIVIL ENGINEERING DESIGN

AMERICAN ELECTRIC POWER SERVICE CORPORATION

OBSERVATION
 WELL

CDS-04

COMPANY APCO MOUNTAINEER PLANT
 PROJECT ASH LANDFILL
 COORDINATES N.710956.09 E.1730893.81
 DATE INSTALLED 8-18-92
 LATITUDE 38 56 55.06653
 LONGITUDE 81 56 46.18349

NOTE: CASING PROTECTOR DETAILS
 NOT SHOWN

WELL CONSTRUCTION
 SUMMARY ELEVATION
 (ft. NGVD)
 WELL NO. MW-20
 REF. DATUM PT. 682.03
 GRADE 679.99

- 1 GROUT SEAL BENTONITE PELLETS
- 2 BENTONITE SEAL
- 3 SCREEN 2" DIA. 20 SLOT PVC
- 4 GRAVEL PACK #4 OHIO QUARTZ
- 5 N.A.
- 6 RISER PIPE 2" DIA. SCH. 40

BORE HOLE DIAMETER 6"
 CLUSTERED WELL SITE WITH
 MW-15.

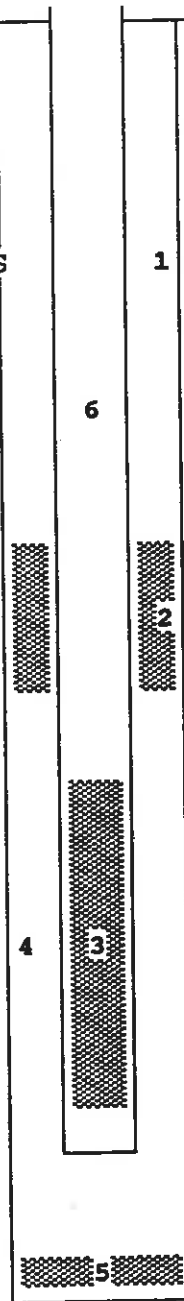

BENTONITE SEAL FROM 632.68 TO
 BOTTOM OF CONCRETE PAD.
 BENTONITE PELLETS WERE HYDRATED
 DURING INSTALLATION.

TOP OF GRAVEL PACK 672.09

TOP OF SCREEN 671.09

BOTTOM OF SCREEN 662.09

BOTTOM OF BLANK SECTION 660.99

BOTTOM OF GRAVEL PACK 659.49

BOTTOM OF BORE HOLE 659.49

GEOTECHNICAL ENGINEERING SECTION
 CIVIL ENGINEERING DESIGN

AMERICAN ELECTRIC POWER SERVICE CORPORATION

OBSERVATION
 WELL

CDS-04



AEP 1992, 2005, 2006, 2008

**Monitoring Well Construction
Diagrams**

**MW-05 to MW-22, MW-24 to
MW-26, MW-34 to MW-44,
MW-44D, MW-44I, MW-44S**

AMERICAN ELECTRIC POWER SERVICE CORPORATION
 AEP CIVIL ENGINEERING LABORATORY
 MONITORING WELL CONSTRUCTION







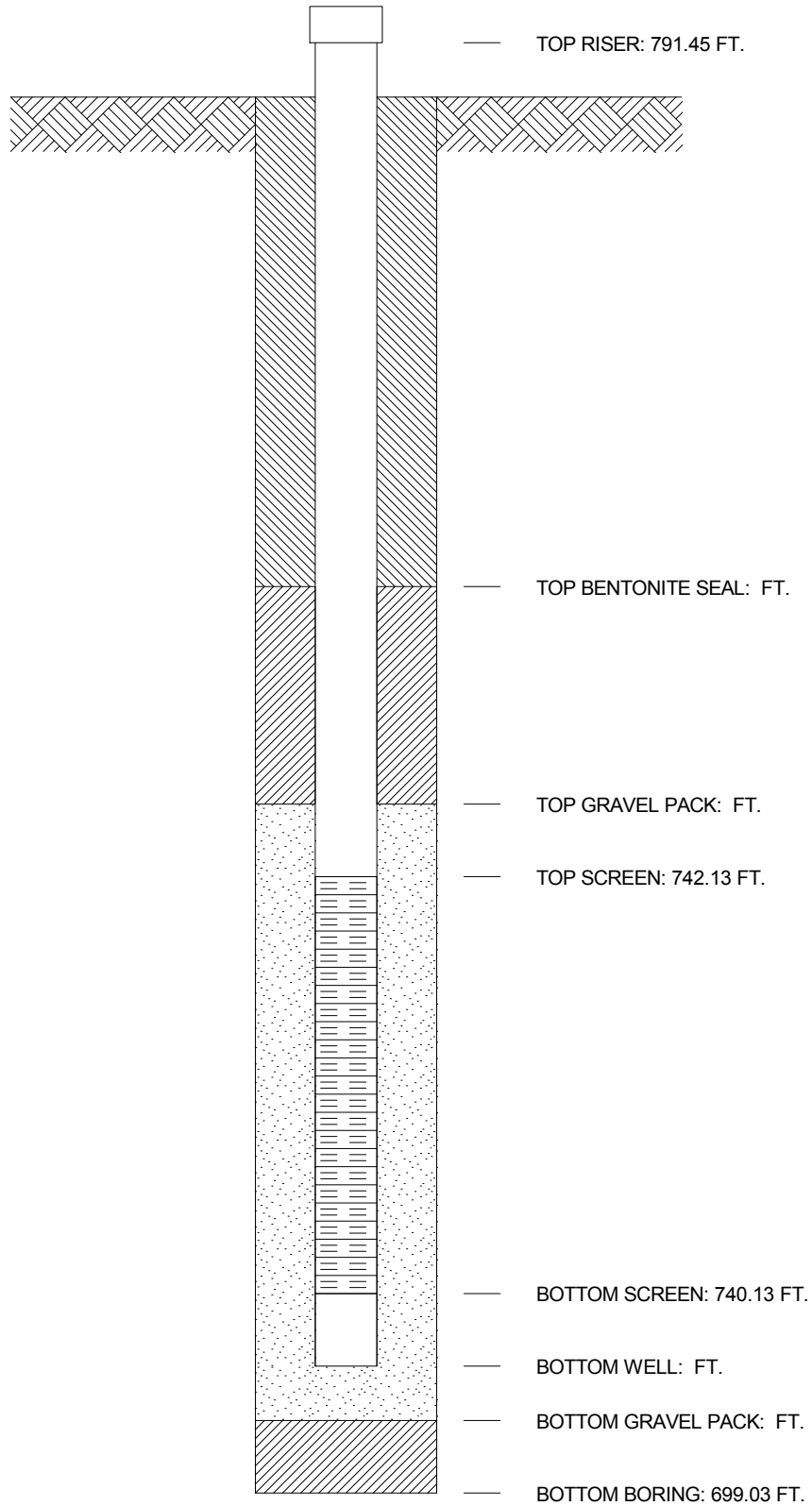

JOB NUMBER _____
 COMPANY **APPALACHIAN POWER COMPANY**
 PROJECT **MOUNTAINEER LBR LANDFILL**
 COORDINATES **N 711,462.7 E 1,728,597.8**
 SYSTEM _____

WELL No. _____ BORING No. **MW-05** INSTALLED **6/23/92**

GROUND ELEVATION 788.93 FT.



-  GROUT SEAL:
-  BENTONITE SEAL:
-  SCREEN: dia., ,
-  GRAVEL PACK:
-  RISER PIPE: , dia.,
-  SPACERS, DEPTH:

AMERICAN ELECTRIC POWER SERVICE CORPORATION
 AEP CIVIL ENGINEERING LABORATORY
 MONITORING WELL CONSTRUCTION







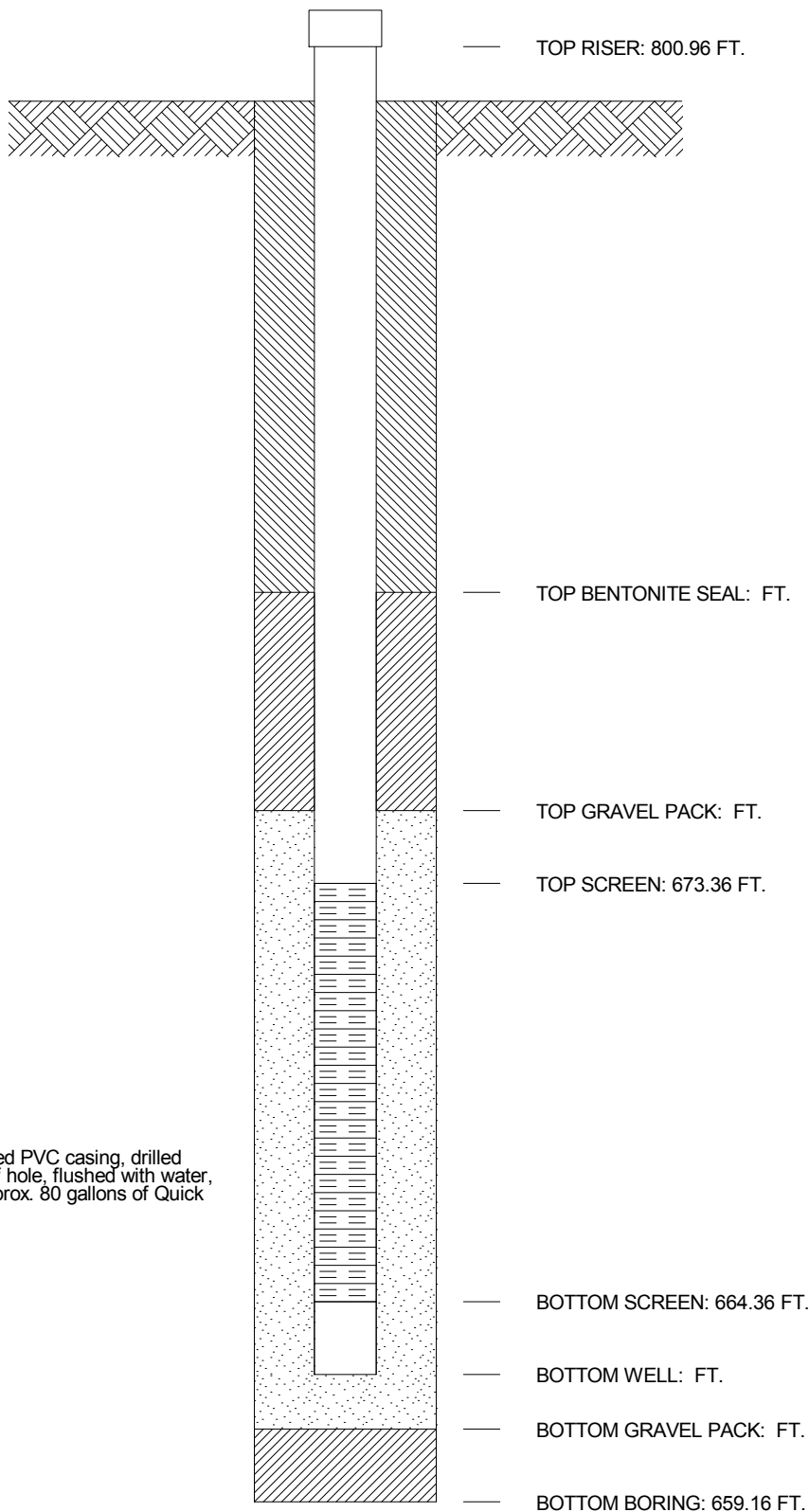

JOB NUMBER _____
 COMPANY **APPALACHIAN POWER COMPANY**
 PROJECT **MOUNTAINEER LBR LANDFILL**
 COORDINATES **N 712,003.9 E 1,729,676.1**
 SYSTEM _____

WELL No. _____ BORING No. **MW-06** INSTALLED **7/16/92**

GROUND ELEVATION 799.16 FT.



-  GROUT SEAL:
-  BENTONITE SEAL:
-  SCREEN: dia., ,
-  GRAVEL PACK:
-  RISER PIPE: , dia.,
-  SPACERS, DEPTH:

WV00019







Well abandoned 8/18/99 - Pulled PVC casing, drilled 5.25" roller bit to bottom of hole, flushed with water, & triemie grouted with approx. 80 gallons of Quick grout

AMERICAN ELECTRIC POWER SERVICE CORPORATION
 AEP CIVIL ENGINEERING LABORATORY
 MONITORING WELL CONSTRUCTION



JOB NUMBER _____
 COMPANY **APPALACHIAN POWER COMPANY** WELL No. **9621** BORING No. **MW-07** INSTALLED **6/19/92**
 PROJECT **MOUNTAINEER LBR LANDFILL**
 COORDINATES **N 711,982.1 E 1,729,623.0**
 SYSTEM _____

GROUND ELEVATION 800.46 FT.

-  GROUT SEAL: 50 GALLONS QUICK GROUT
-  BENTONITE SEAL: 50 # BENTONITE CHIPS
-  SCREEN: 2.0 dia., PVC SCH 40 20 SLOT, 9.0
-  GRAVEL PACK: 175# No.4 OHIO QUARTZ
-  RISER PIPE: 2.0, dia., PVC SCH 40
-  SPACERS, DEPTH: 25', 26'

WV00019

Well abandoned 8/17/99 - Pulled PVC casing, drilled 2.875" roller bit to bottom of hole, flushed with water, & triemie grouted with approx. 50 gallons of Quick grout

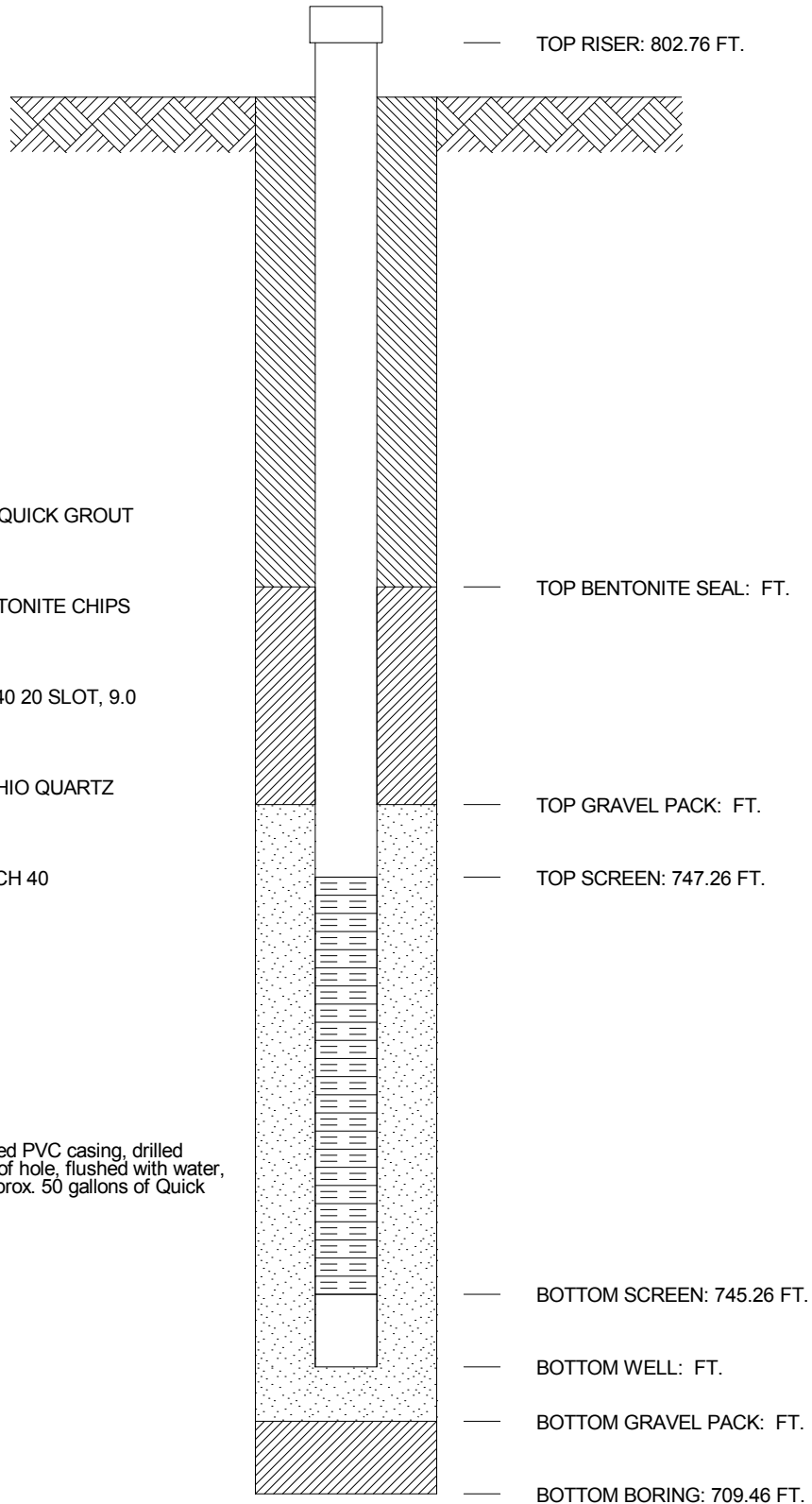







AMERICAN ELECTRIC POWER SERVICE CORPORATION
 AEP CIVIL ENGINEERING LABORATORY
 MONITORING WELL CONSTRUCTION



JOB NUMBER _____
 COMPANY **APPALACHIAN POWER COMPANY**
 PROJECT **MOUNTAINEER LBR LANDFILL**
 COORDINATES **N 710,780.9 E 1,730,856.4**
 SYSTEM _____

WELL No. _____ BORING No. **MW-08** INSTALLED **7/29/92**

GROUND ELEVATION 675.49 FT.

-  GROUT SEAL:
-  BENTONITE SEAL:
-  SCREEN: dia., ,
-  GRAVEL PACK:
-  RISER PIPE: , dia.,
-  SPACERS, DEPTH:

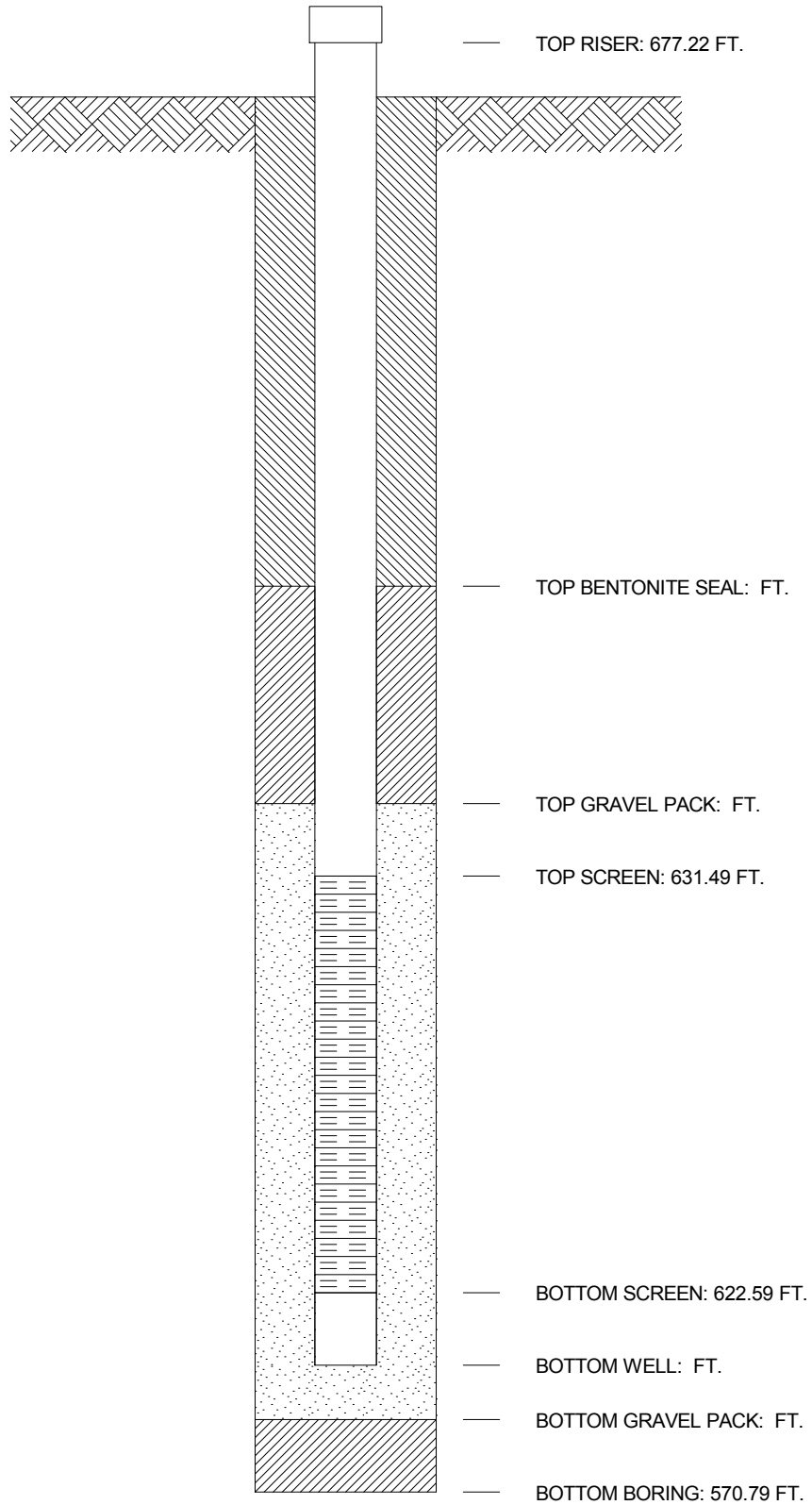

AMERICAN ELECTRIC POWER SERVICE CORPORATION
 AEP CIVIL ENGINEERING LABORATORY
 MONITORING WELL CONSTRUCTION







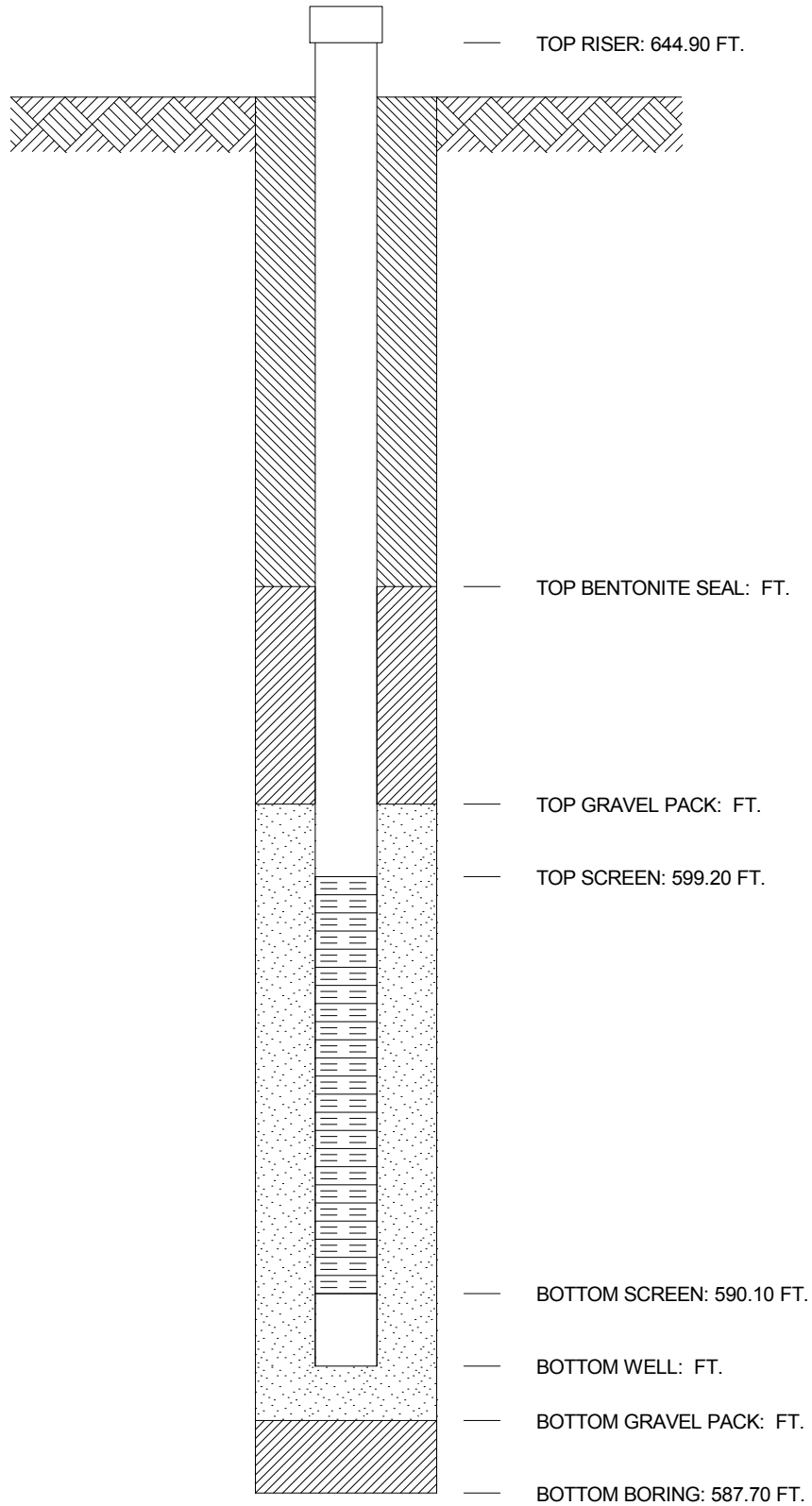

JOB NUMBER _____
 COMPANY **APPALACHIAN POWER COMPANY**
 PROJECT **MOUNTAINEER LBR LANDFILL**
 COORDINATES **N 712,268.5 E 1,732,217.4**
 SYSTEM _____

WELL No. _____ BORING No. **MW-09** INSTALLED **8/13/92**

GROUND ELEVATION 643.00 FT.



-  GROUT SEAL:
-  BENTONITE SEAL:
-  SCREEN: dia., ,
-  GRAVEL PACK:
-  RISER PIPE: , dia.,
-  SPACERS, DEPTH:







AMERICAN ELECTRIC POWER SERVICE CORPORATION
 AEP CIVIL ENGINEERING LABORATORY
 MONITORING WELL CONSTRUCTION

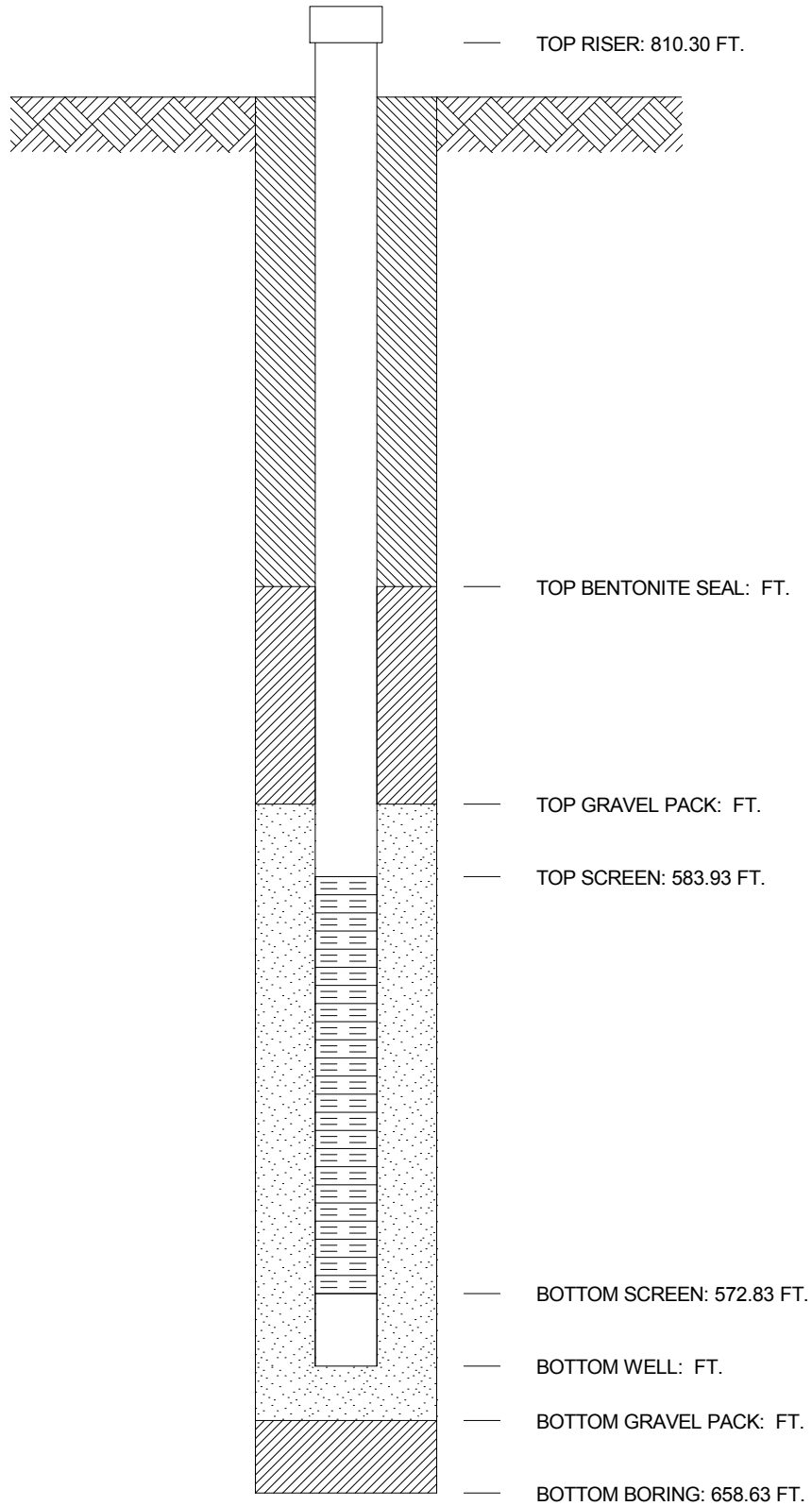

JOB NUMBER _____
 COMPANY **APPALACHIAN POWER COMPANY** WELL No. _____ BORING No. **MW-10** INSTALLED **7/8/92**
 PROJECT **MOUNTAINEER LBR LANDFILL**
 COORDINATES **N 710,968.6 E 1,730,231.8**
 SYSTEM _____

GROUND ELEVATION 810.83 FT.









-  GROUT SEAL:
-  BENTONITE SEAL:
-  SCREEN: dia., ,
-  GRAVEL PACK:
-  RISER PIPE: , dia.,
-  SPACERS, DEPTH:

AMERICAN ELECTRIC POWER SERVICE CORPORATION
 AEP CIVIL ENGINEERING LABORATORY
 MONITORING WELL CONSTRUCTION



JOB NUMBER _____
 COMPANY **APPALACHIAN POWER COMPANY** WELL No. _____ BORING No. **MW-11** INSTALLED _____
 PROJECT **MOUNTAINEER LBR LANDFILL**
 COORDINATES _____
 SYSTEM _____

GROUND ELEVATION FT. _____

-  GROUT SEAL:
-  BENTONITE SEAL:
-  SCREEN: dia., ,
-  GRAVEL PACK:
-  RISER PIPE: , dia.,
-  SPACERS, DEPTH:

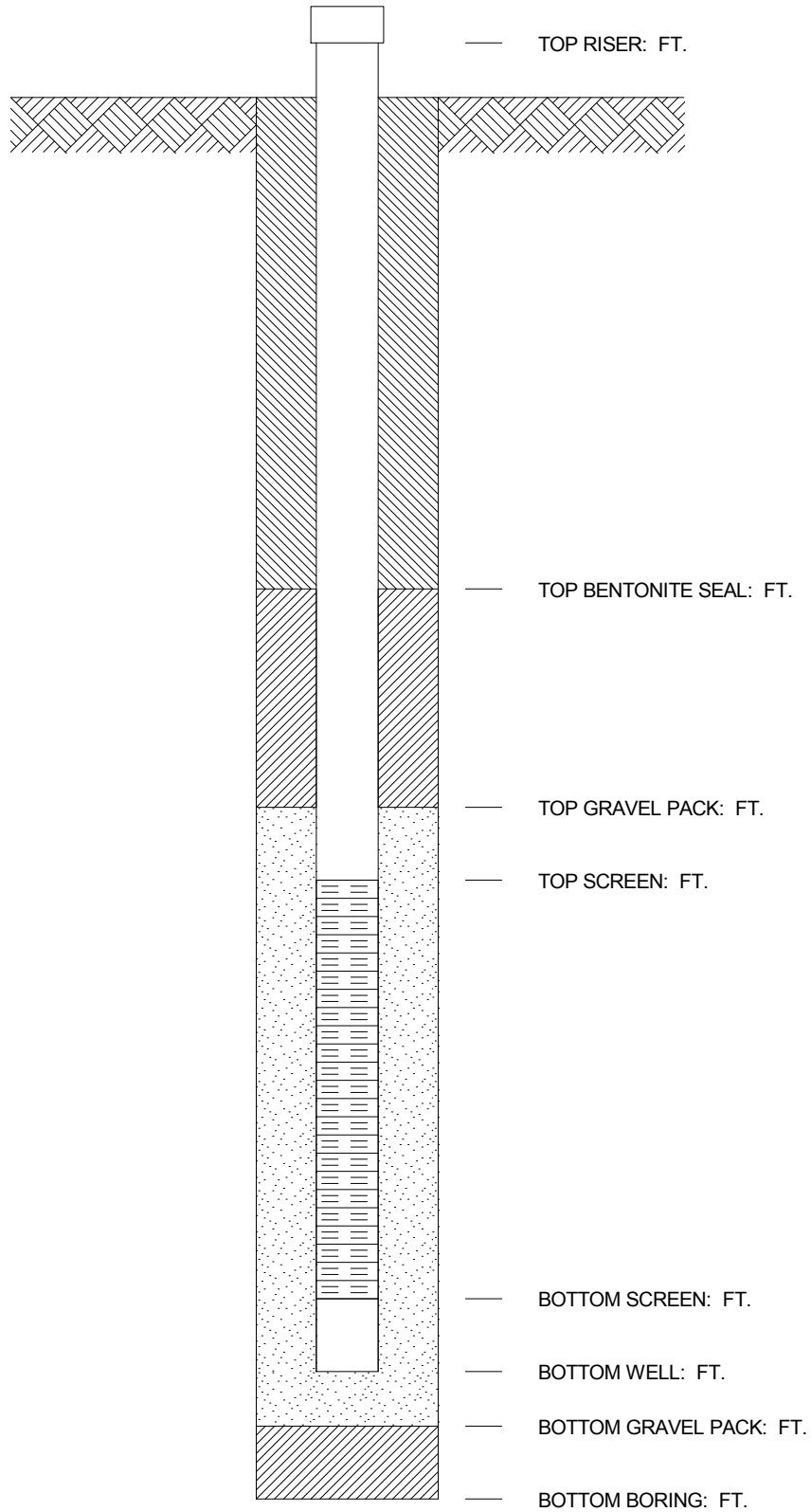

AMERICAN ELECTRIC POWER SERVICE CORPORATION
 AEP CIVIL ENGINEERING LABORATORY
 MONITORING WELL CONSTRUCTION







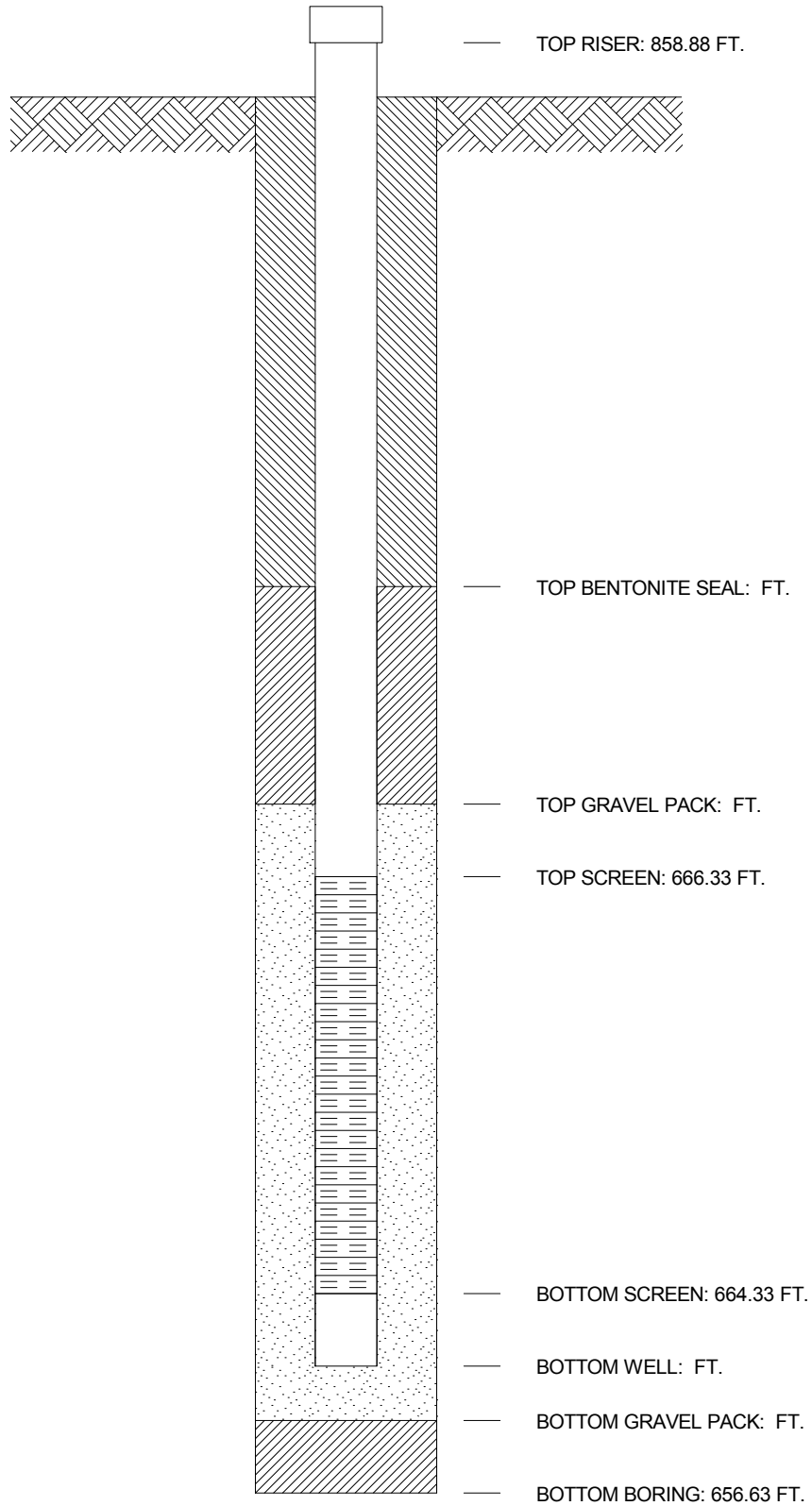

JOB NUMBER _____
 COMPANY **APPALACHIAN POWER COMPANY**
 PROJECT **MOUNTAINEER LBR LANDFILL**
 COORDINATES **N 709,162.5 E 1,728,963.4**
 SYSTEM _____

WELL No. _____ BORING No. **MW-12** INSTALLED **5/6/92**

GROUND ELEVATION 856.93 FT.



-  GROUT SEAL:
-  BENTONITE SEAL:
-  SCREEN: dia., ,
-  GRAVEL PACK:
-  RISER PIPE: , dia.,
-  SPACERS, DEPTH:

AMERICAN ELECTRIC POWER SERVICE CORPORATION
 AEP CIVIL ENGINEERING LABORATORY
 MONITORING WELL CONSTRUCTION



JOB NUMBER _____
 COMPANY **APPALACHIAN POWER COMPANY**
 PROJECT **MOUNTAINEER LBR LANDFILL**
 COORDINATES **N 710,337.4 E 1,731,154.1**
 SYSTEM _____

WELL No. **9622** BORING No. **MW-13** INSTALLED **5/13/92**

GROUND ELEVATION 802.01 FT.

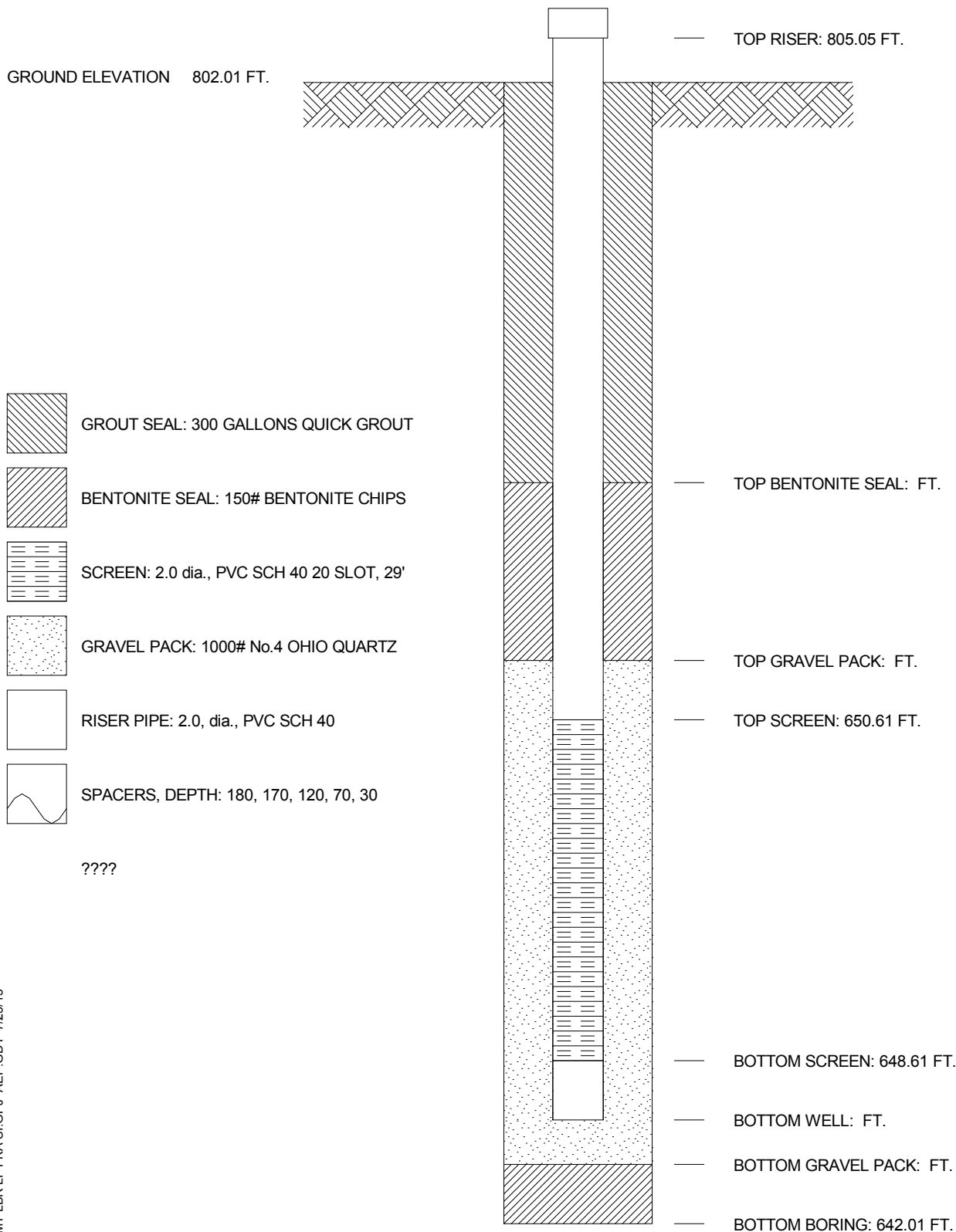







AMERICAN ELECTRIC POWER SERVICE CORPORATION
 AEP CIVIL ENGINEERING LABORATORY
 MONITORING WELL CONSTRUCTION

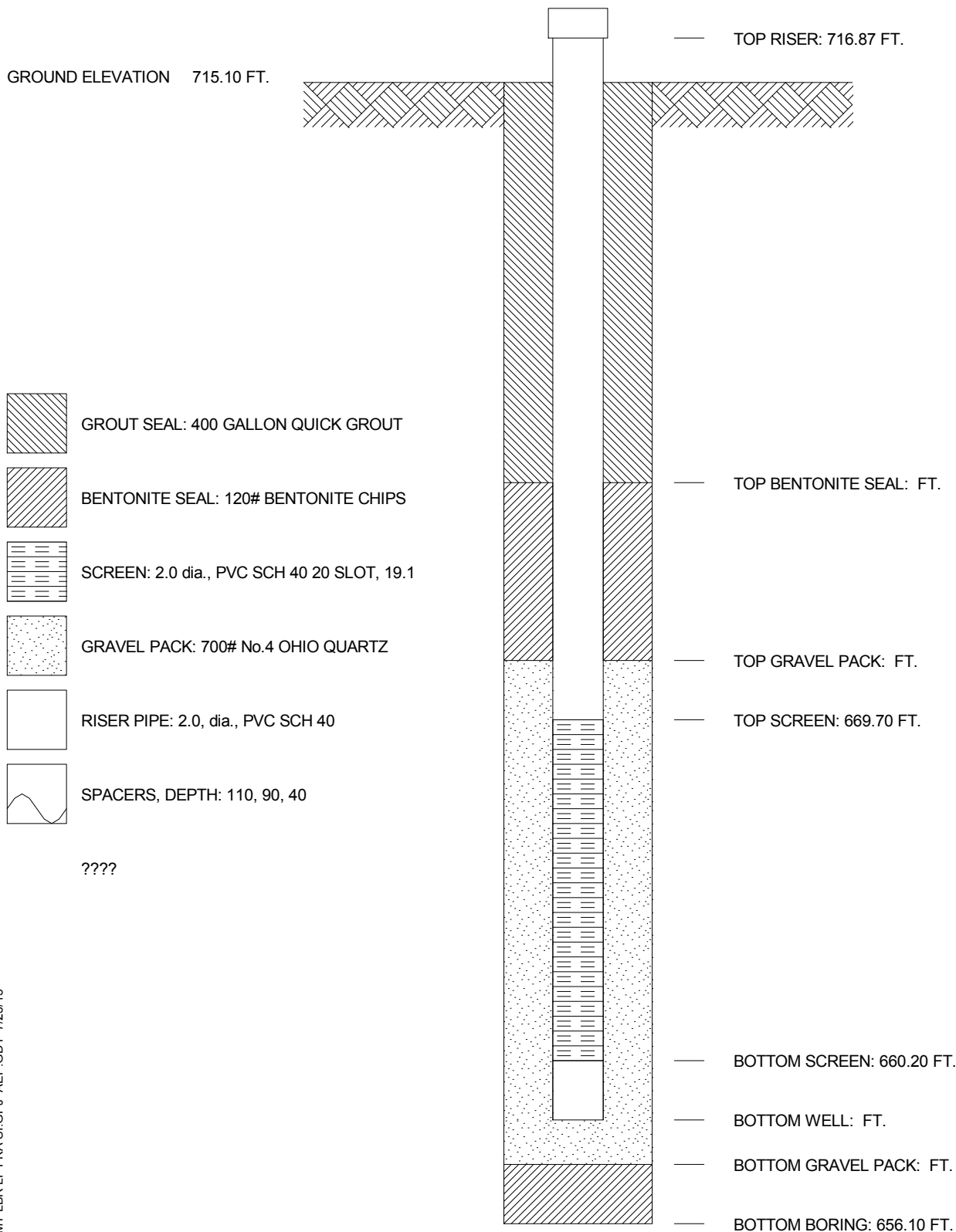

JOB NUMBER _____
 COMPANY **APPALACHIAN POWER COMPANY** WELL No. **9623** BORING No. **MW-14** INSTALLED **8/11/92**
 PROJECT **MOUNTAINEER LBR LANDFILL**
 COORDINATES **N 710,272.6 E 1,729,225.4**
 SYSTEM _____

GROUND ELEVATION 715.10 FT.



-  GROUT SEAL: 400 GALLON QUICK GROUT
-  BENTONITE SEAL: 120# BENTONITE CHIPS
-  SCREEN: 2.0 dia., PVC SCH 40 20 SLOT, 19.1
-  GRAVEL PACK: 700# No.4 OHIO QUARTZ
-  RISER PIPE: 2.0, dia., PVC SCH 40
-  SPACERS, DEPTH: 110, 90, 40

????

AMERICAN ELECTRIC POWER SERVICE CORPORATION
 AEP CIVIL ENGINEERING LABORATORY
 MONITORING WELL CONSTRUCTION







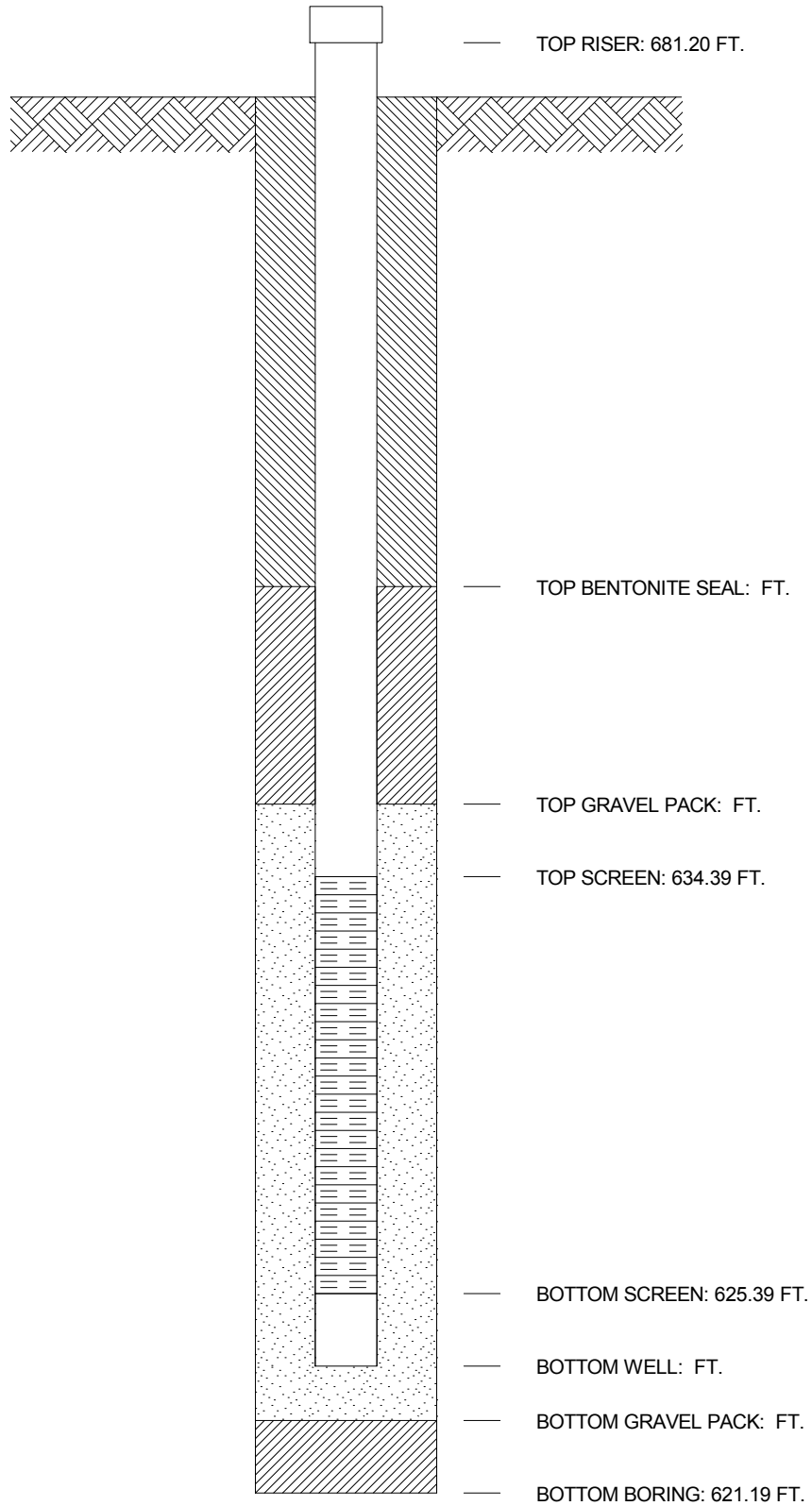

JOB NUMBER _____
 COMPANY **APPALACHIAN POWER COMPANY**
 PROJECT **MOUNTAINEER LBR LANDFILL**
 COORDINATES **N 710,943.8 E 1,730,886.1**
 SYSTEM _____

WELL No. _____ BORING No. **MW-15** INSTALLED **7/22/92**

GROUND ELEVATION 679.29 FT.



-  GROUT SEAL:
-  BENTONITE SEAL:
-  SCREEN: dia., ,
-  GRAVEL PACK:
-  RISER PIPE: , dia.,
-  SPACERS, DEPTH:

AMERICAN ELECTRIC POWER SERVICE CORPORATION
 AEP CIVIL ENGINEERING LABORATORY
 MONITORING WELL CONSTRUCTION







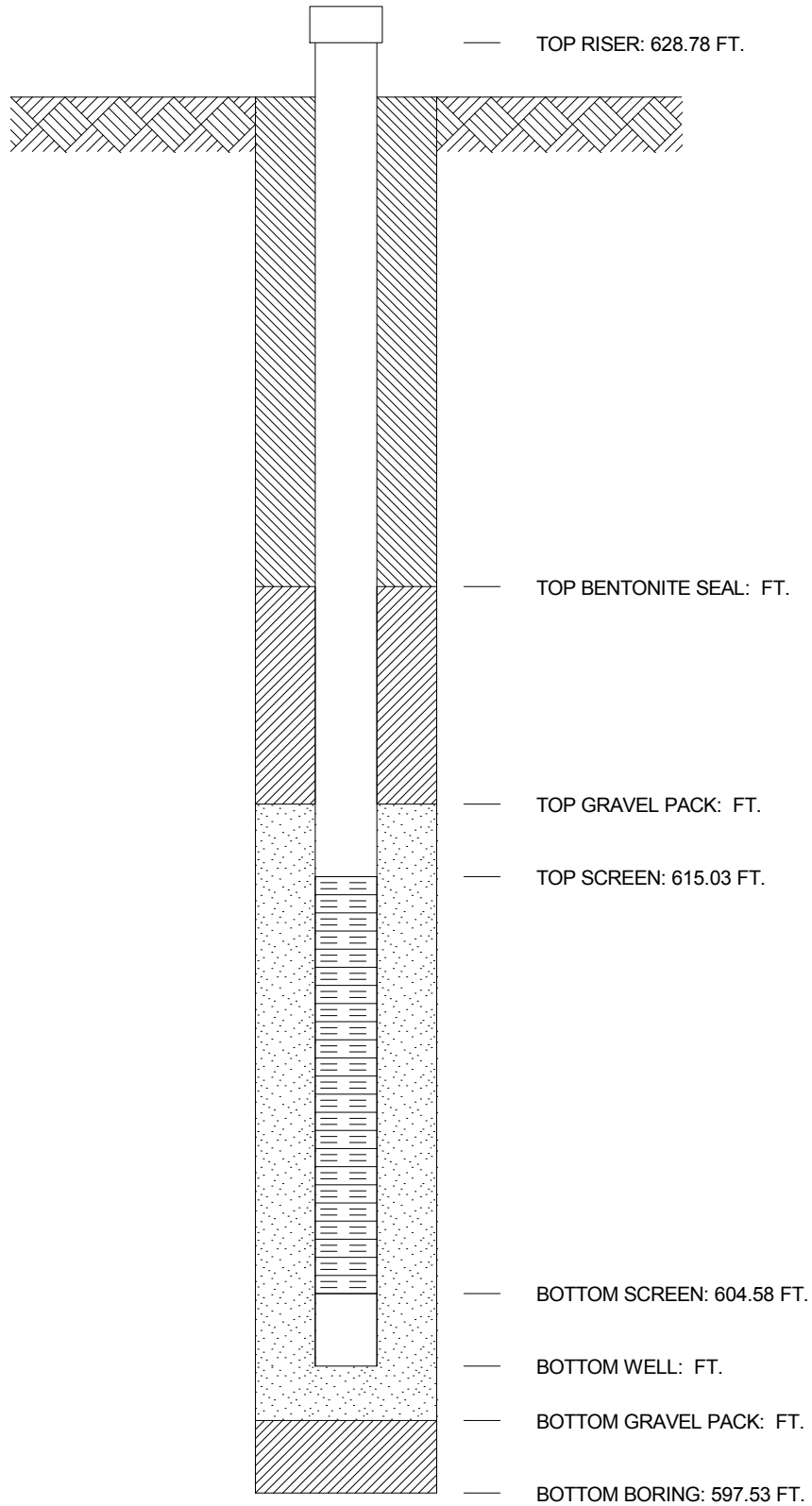

JOB NUMBER _____
 COMPANY **APPALACHIAN POWER COMPANY**
 PROJECT **MOUNTAINEER LBR LANDFILL**
 COORDINATES **N 714,546.9 E 1,733,259.1**
 SYSTEM _____

WELL No. _____ BORING No. **MW-16** INSTALLED **5/21/92**

GROUND ELEVATION 626.03 FT.



-  GROUT SEAL:
-  BENTONITE SEAL:
-  SCREEN: dia., ,
-  GRAVEL PACK:
-  RISER PIPE: , dia.,
-  SPACERS, DEPTH:

AMERICAN ELECTRIC POWER SERVICE CORPORATION
 AEP CIVIL ENGINEERING LABORATORY
 MONITORING WELL CONSTRUCTION







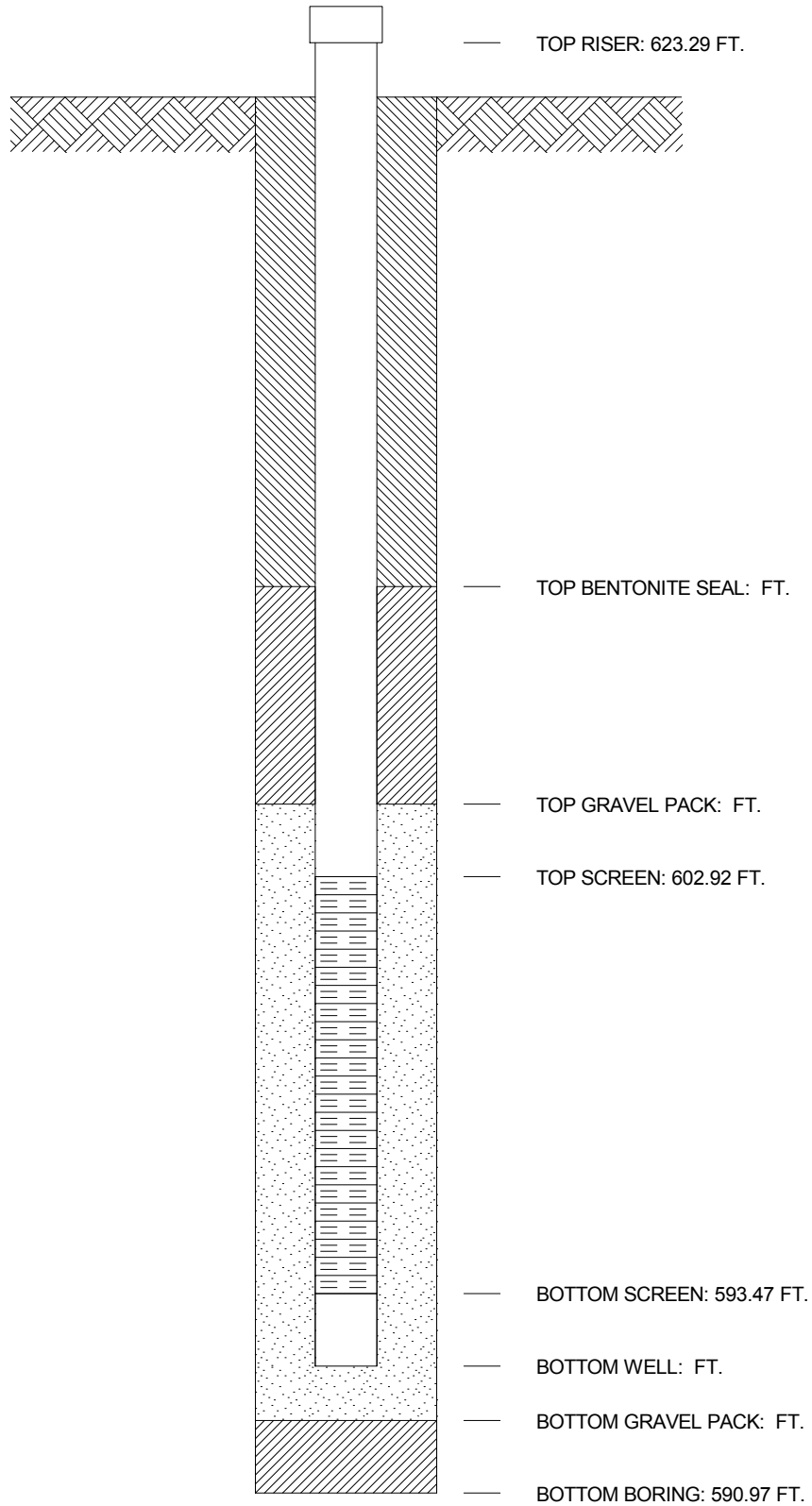

JOB NUMBER _____
 COMPANY **APPALACHIAN POWER COMPANY**
 PROJECT **MOUNTAINEER LBR LANDFILL**
 COORDINATES **N 714,833.5 E 1,733,260.6**
 SYSTEM _____

WELL No. _____ BORING No. **MW-17** INSTALLED **5/20/92**

GROUND ELEVATION 621.47 FT.



-  GROUT SEAL:
-  BENTONITE SEAL:
-  SCREEN: dia., ,
-  GRAVEL PACK:
-  RISER PIPE: , dia.,
-  SPACERS, DEPTH:

AMERICAN ELECTRIC POWER SERVICE CORPORATION
 AEP CIVIL ENGINEERING LABORATORY
 MONITORING WELL CONSTRUCTION







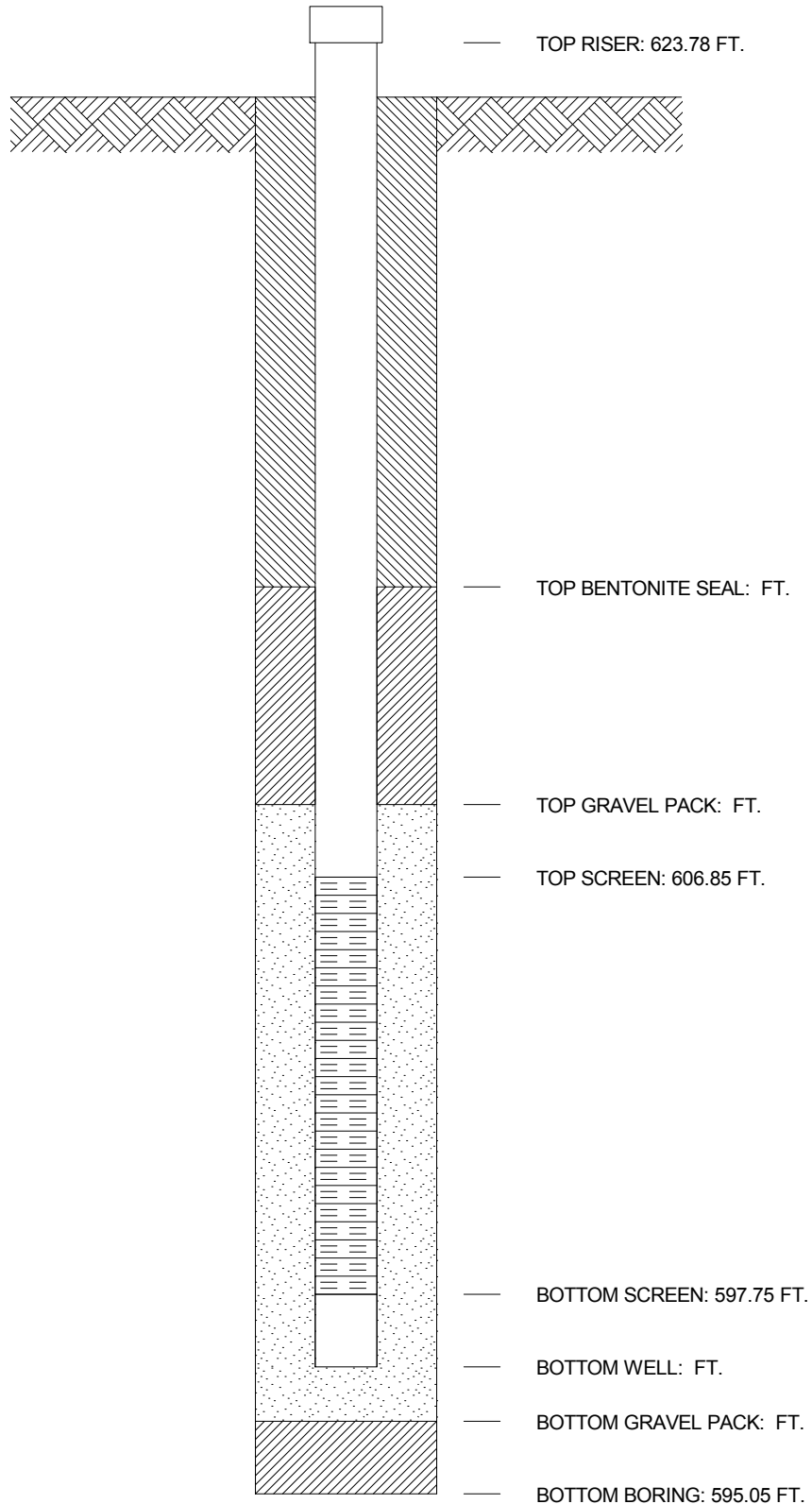

JOB NUMBER _____
 COMPANY **APPALACHIAN POWER COMPANY**
 PROJECT **MOUNTAINEER LBR LANDFILL**
 COORDINATES **N 714,922.0 E 1,733,257.8**
 SYSTEM _____

WELL No. _____ BORING No. **MW-18** INSTALLED **5/19/92**

GROUND ELEVATION 621.95 FT.



-  GROUT SEAL:
-  BENTONITE SEAL:
-  SCREEN: dia., ,
-  GRAVEL PACK:
-  RISER PIPE: , dia.,
-  SPACERS, DEPTH:

AMERICAN ELECTRIC POWER SERVICE CORPORATION
 AEP CIVIL ENGINEERING LABORATORY
 MONITORING WELL CONSTRUCTION







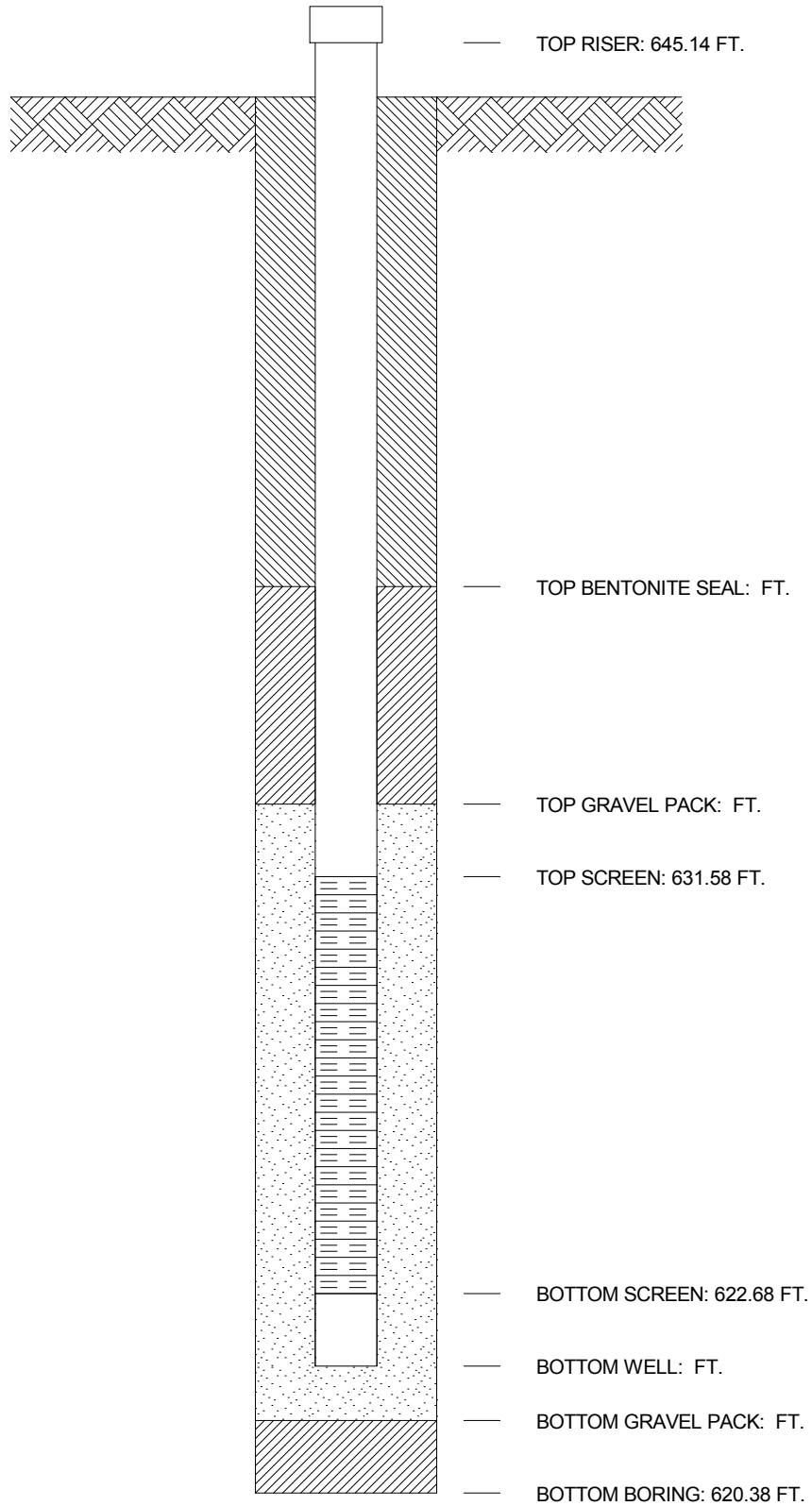

JOB NUMBER _____
 COMPANY **APPALACHIAN POWER COMPANY**
 PROJECT **MOUNTAINEER LBR LANDFILL**
 COORDINATES **N 712,263.7 E 1,732,224.9**
 SYSTEM _____

WELL No. _____ BORING No. **MW-19** INSTALLED **8/13/92**

GROUND ELEVATION 643.18 FT.



-  GROUT SEAL:
-  BENTONITE SEAL:
-  SCREEN: dia., ,
-  GRAVEL PACK:
-  RISER PIPE: , dia.,
-  SPACERS, DEPTH:

AMERICAN ELECTRIC POWER SERVICE CORPORATION
 AEP CIVIL ENGINEERING LABORATORY
 MONITORING WELL CONSTRUCTION







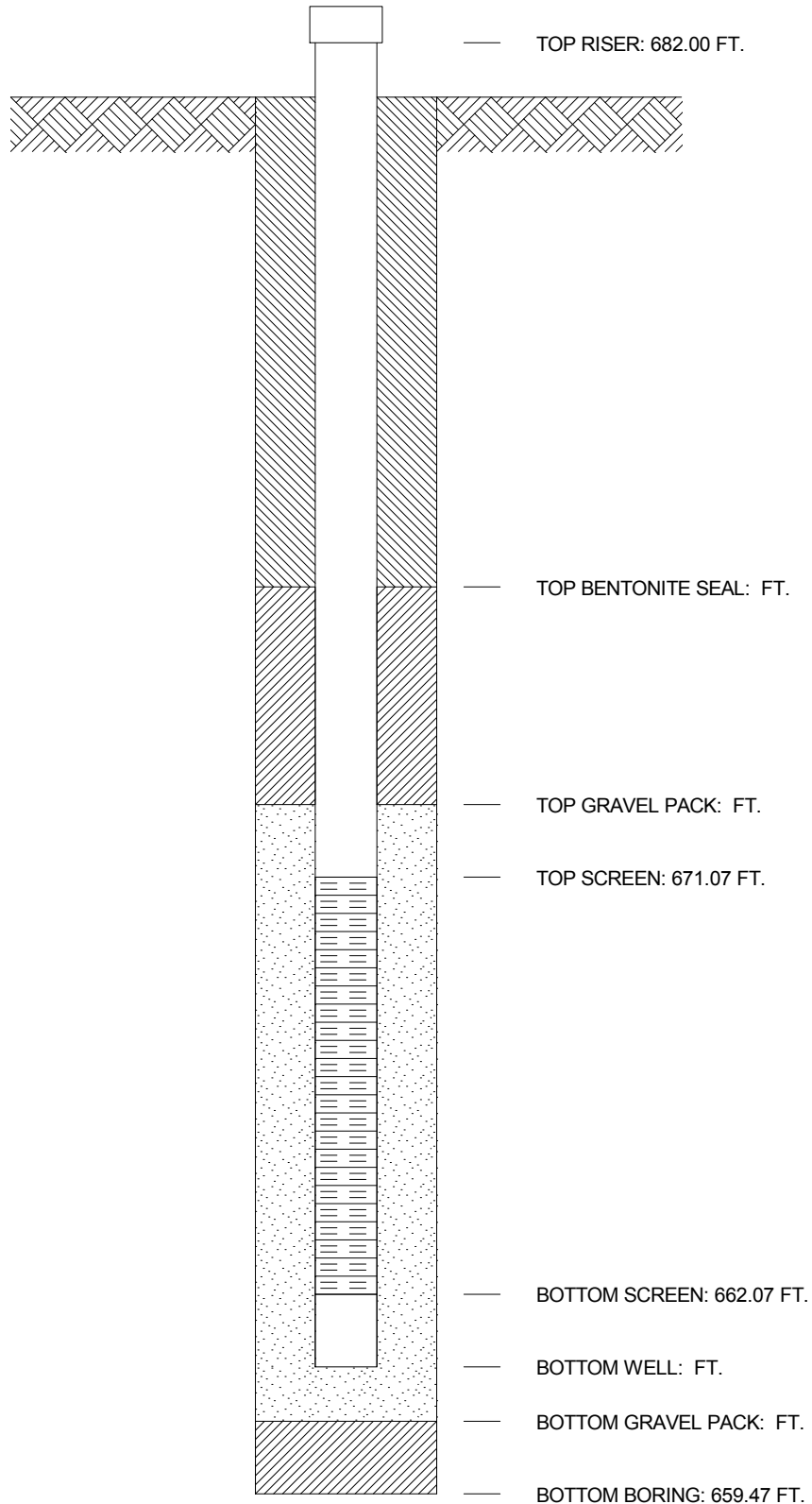

JOB NUMBER _____
 COMPANY **APPALACHIAN POWER COMPANY**
 PROJECT **MOUNTAINEER LBR LANDFILL**
 COORDINATES **N 710,956.1 E 1,730,893.8**
 SYSTEM _____

WELL No. _____ BORING No. **MW-20** INSTALLED **8/18/92**

GROUND ELEVATION 679.97 FT.



-  GROUT SEAL:
-  BENTONITE SEAL:
-  SCREEN: dia., ,
-  GRAVEL PACK:
-  RISER PIPE: , dia.,
-  SPACERS, DEPTH:

AMERICAN ELECTRIC POWER SERVICE CORPORATION
 AEP CIVIL ENGINEERING LABORATORY
 MONITORING WELL CONSTRUCTION



JOB NUMBER _____
 COMPANY **APPALACHIAN POWER COMPANY**
 PROJECT **MOUNTAINEER LBR LANDFILL**
 COORDINATES **N 710,790.4 E 1,730,872.3**
 SYSTEM _____

WELL No. _____ BORING No. **MW-21** INSTALLED **9/2/92**

GROUND ELEVATION 674.90 FT.

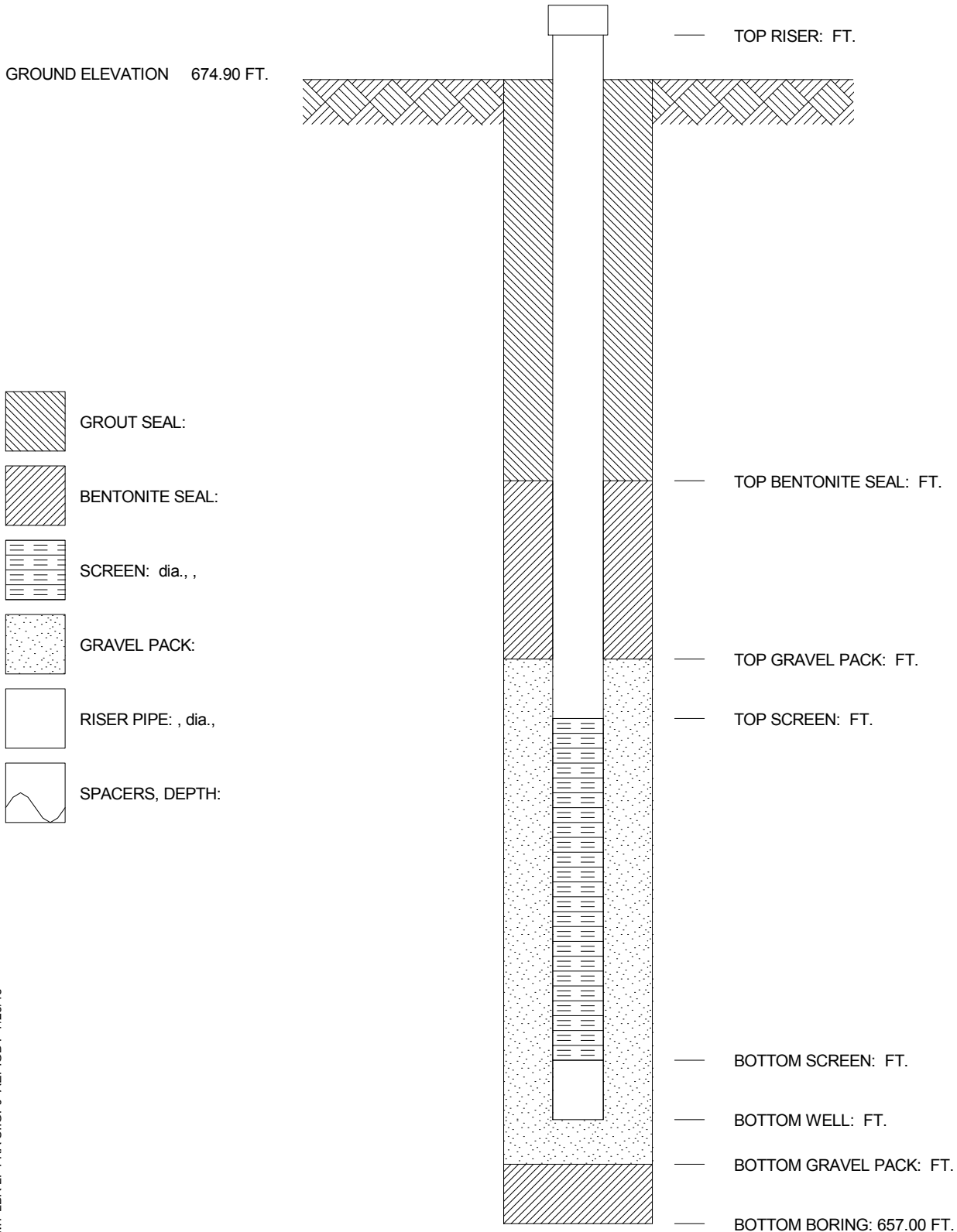







AMERICAN ELECTRIC POWER SERVICE CORPORATION
 AEP CIVIL ENGINEERING LABORATORY
 MONITORING WELL CONSTRUCTION



JOB NUMBER _____
 COMPANY **APPALACHIAN POWER COMPANY**
 PROJECT **MOUNTAINEER LBR LANDFILL**
 COORDINATES _____
 SYSTEM _____

WELL No. _____ BORING No. **MW-22** INSTALLED **7/1/92**

GROUND ELEVATION FT. _____

-  GROUT SEAL:
-  BENTONITE SEAL:
-  SCREEN: dia., ,
-  GRAVEL PACK:
-  RISER PIPE: , dia.,
-  SPACERS, DEPTH:

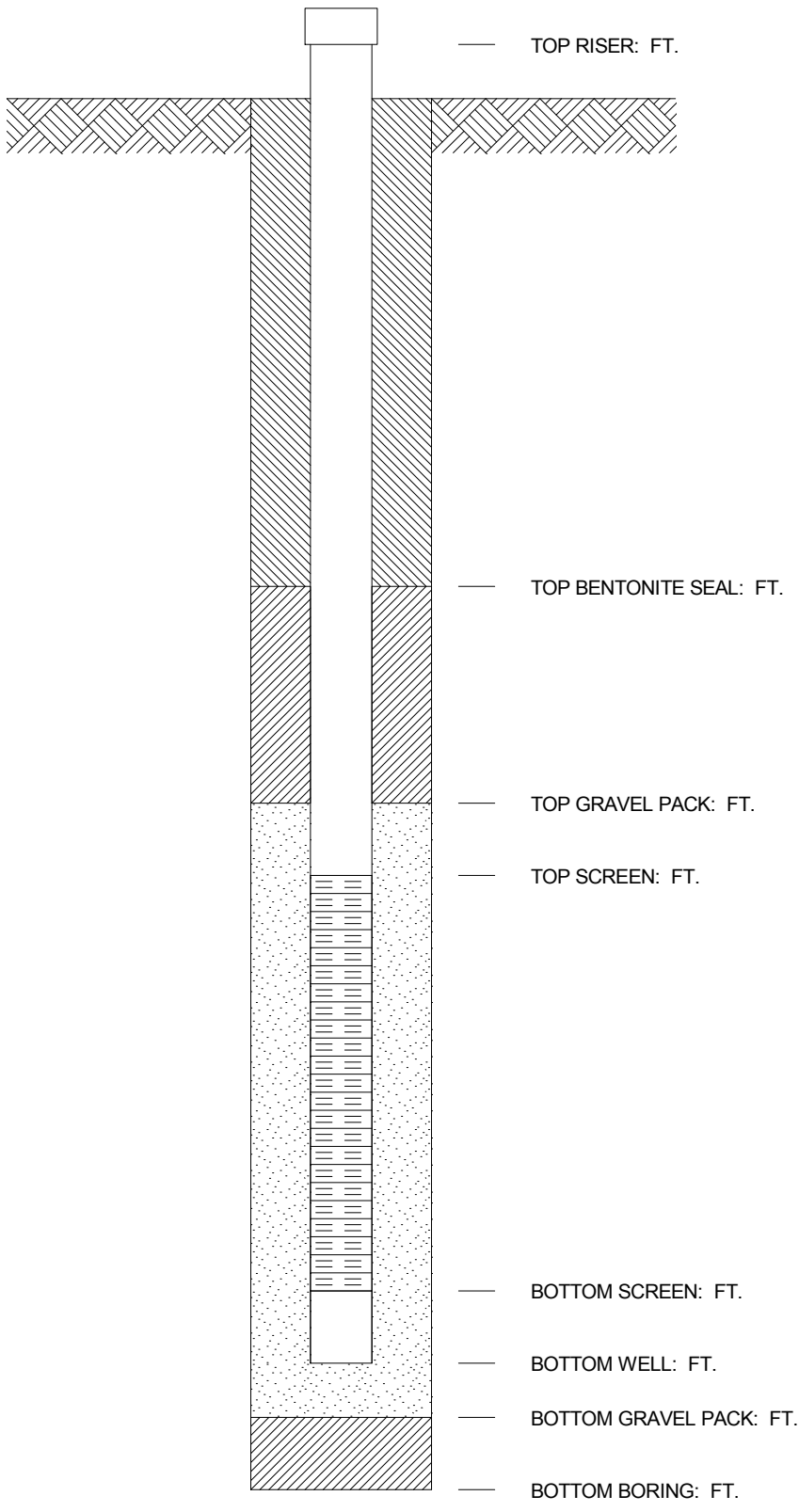







AMERICAN ELECTRIC POWER SERVICE CORPORATION
 AEP CIVIL ENGINEERING LABORATORY
 MONITORING WELL CONSTRUCTION

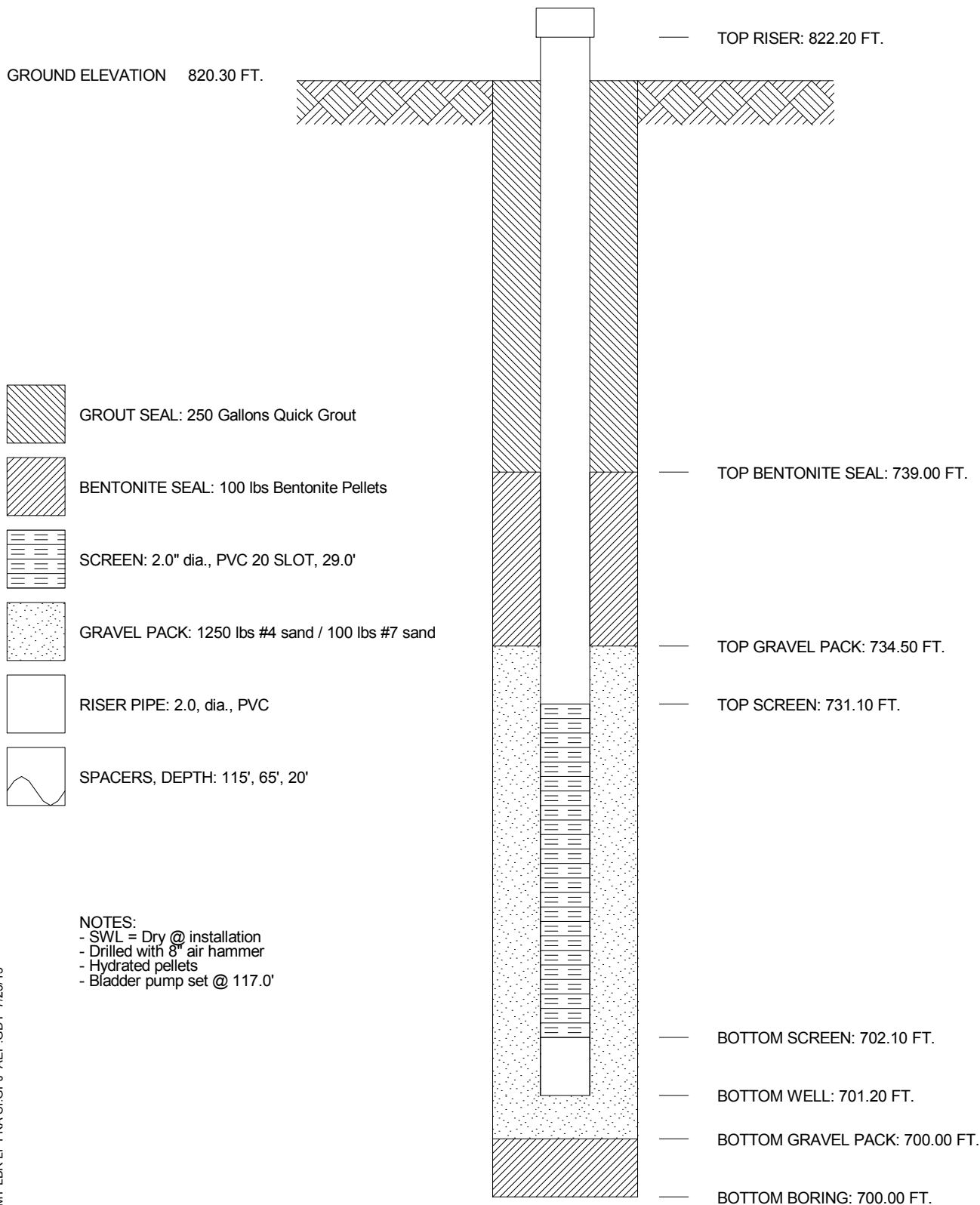

JOB NUMBER _____
 COMPANY **APPALACHIAN POWER COMPANY** WELL No. **MW-24** BORING No. **MW-24** INSTALLED **8/17/05**
 PROJECT **MOUNTAINEER LBR LANDFILL**
 COORDINATES **N 709,346.7 E 1,732,174.7**
 SYSTEM **State Plane using NAD27**

GROUND ELEVATION 820.30 FT.



-  GROUT SEAL: 250 Gallons Quick Grout
-  BENTONITE SEAL: 100 lbs Bentonite Pellets
-  SCREEN: 2.0" dia., PVC 20 SLOT, 29.0'
-  GRAVEL PACK: 1250 lbs #4 sand / 100 lbs #7 sand
-  RISER PIPE: 2.0, dia., PVC
-  SPACERS, DEPTH: 115', 65', 20'







NOTES:
 - SWL = Dry @ installation
 - Drilled with 8" air hammer
 - Hydrated pellets
 - Bladder pump set @ 117.0'

AMERICAN ELECTRIC POWER SERVICE CORPORATION
 AEP CIVIL ENGINEERING LABORATORY
 MONITORING WELL CONSTRUCTION



JOB NUMBER _____
 COMPANY **APPALACHIAN POWER COMPANY** WELL No. **MW-25** BORING No. **MW-25** INSTALLED **8/15/05**
 PROJECT **MOUNTAINEER LBR LANDFILL**
 COORDINATES **N 709,352.0 E 1,732,176.8**
 SYSTEM **State Plane using NAD27**

GROUND ELEVATION 820.30 FT.

-  GROUT SEAL: 500 Gallons Quick Grout
-  BENTONITE SEAL: 100 lbs Bentonite Pellets
-  SCREEN: 2.0" dia., PVC 20 SLOT, 48.0'
-  GRAVEL PACK: 1750 lbs #4 sand / 100 lbs #7 sand
-  RISER PIPE: 2.0, dia., PVC
-  SPACERS, DEPTH: 270', 210', 150', 100', 50'

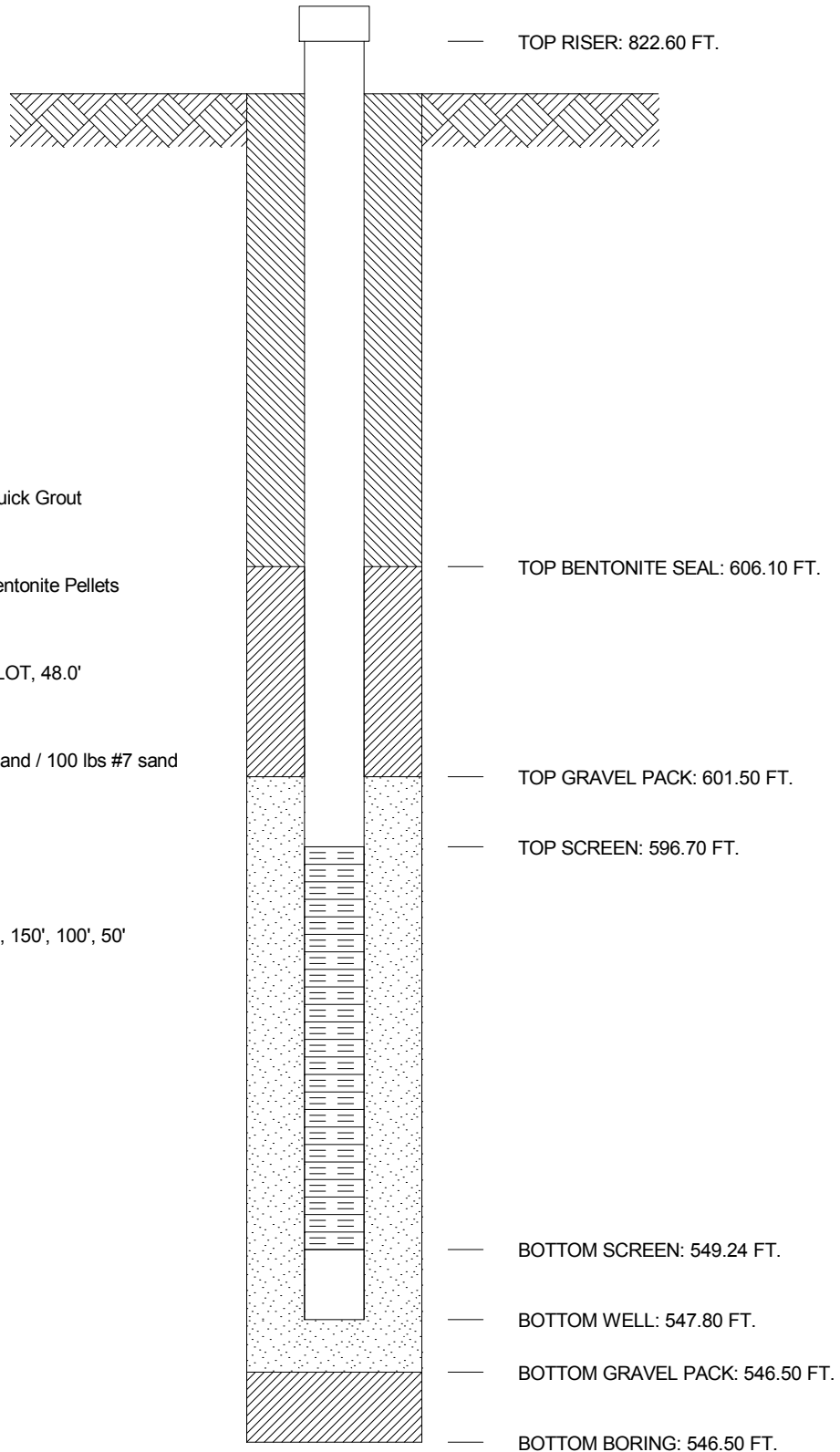







- NOTES:
- SWL = Dry @ installation
 - Drilled with 8" air hammer
 - Hydrated pellets
 - No pump installed

AMERICAN ELECTRIC POWER SERVICE CORPORATION
 AEP CIVIL ENGINEERING LABORATORY
 MONITORING WELL CONSTRUCTION



JOB NUMBER _____
 COMPANY **APPALACHIAN POWER COMPANY** WELL No. **MW-26** BORING No. **MW-26** INSTALLED **8/24/05**
 PROJECT **MOUNTAINEER LBR LANDFILL**
 COORDINATES **N 712,549.0 E 1,731,434.9**
 SYSTEM **State Plane using NAD27**

GROUND ELEVATION 718.20 FT.

-  GROUT SEAL: 50 Gallons Quick Grout
-  BENTONITE SEAL: 100 lbs Bentonite Pellets
-  SCREEN: 2.0" dia., PVC 20 SLOT, 29.0'
-  GRAVEL PACK: 900 lbs #4 sand / 100 lbs #7 sand
-  RISER PIPE: 2.0, dia., PVC
-  SPACERS, DEPTH: 55', 20'

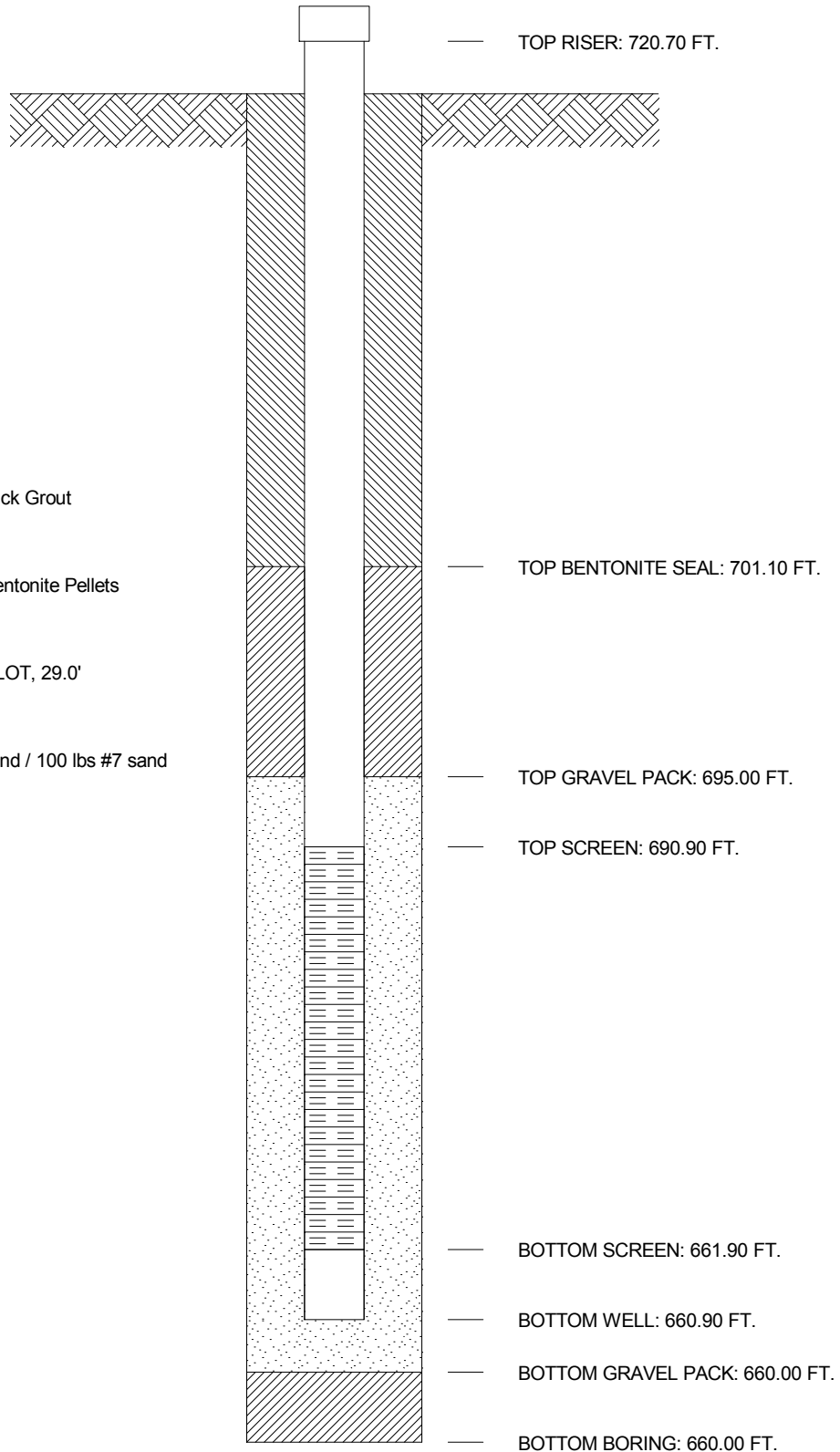

- NOTES:
- SWL = Dry @ installation
 - Drilled with 8" air hammer
 - Hydrated pellets
 - Bladder pump set @ 55.3'

AMERICAN ELECTRIC POWER SERVICE CORPORATION
 AEP CIVIL ENGINEERING LABORATORY
 MONITORING WELL CONSTRUCTION



JOB NUMBER _____
 COMPANY **APPALACHIAN POWER COMPANY** WELL No. **MW-34** BORING No. **MW-34** INSTALLED **8/4/05**
 PROJECT **MOUNTAINEER LBR LANDFILL**
 COORDINATES **N 712,520.8 E 1,730,800.7**
 SYSTEM **State Plane using NAD27**

GROUND ELEVATION 815.60 FT.

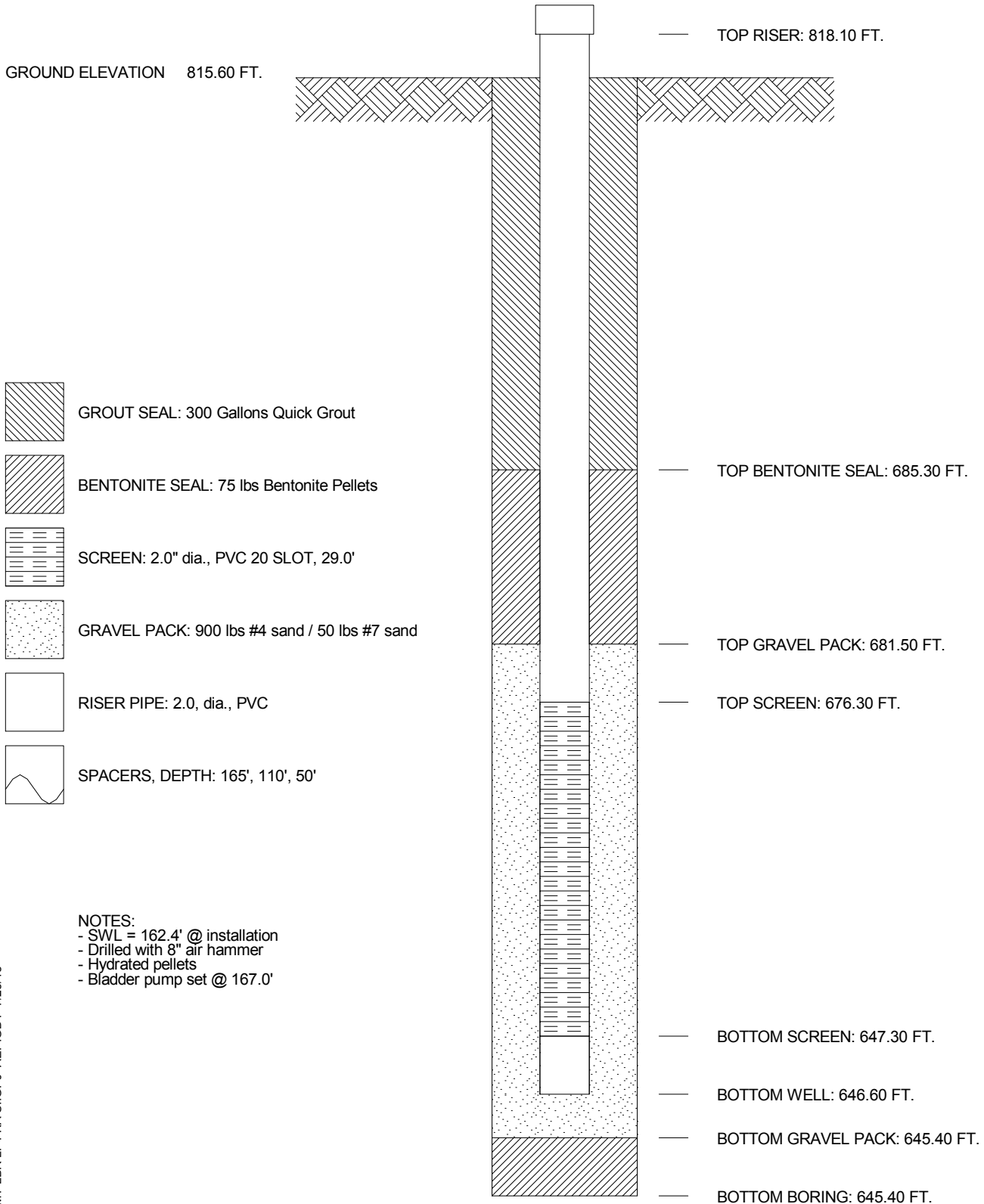

NOTES:
 - SWL = 162.4' @ installation
 - Drilled with 8" air hammer
 - Hydrated pellets
 - Bladder pump set @ 167.0'

AMERICAN ELECTRIC POWER SERVICE CORPORATION
 AEP CIVIL ENGINEERING LABORATORY
 MONITORING WELL CONSTRUCTION



JOB NUMBER _____
 COMPANY **APPALACHIAN POWER COMPANY** WELL No. **MW-35** BORING No. **MW-35** INSTALLED **8/25/05**
 PROJECT **MOUNTAINEER LBR LANDFILL**
 COORDINATES **N 713,097.6 E 1,734,440.0**
 SYSTEM **State Plane using NAD27**

GROUND ELEVATION 790.10 FT.

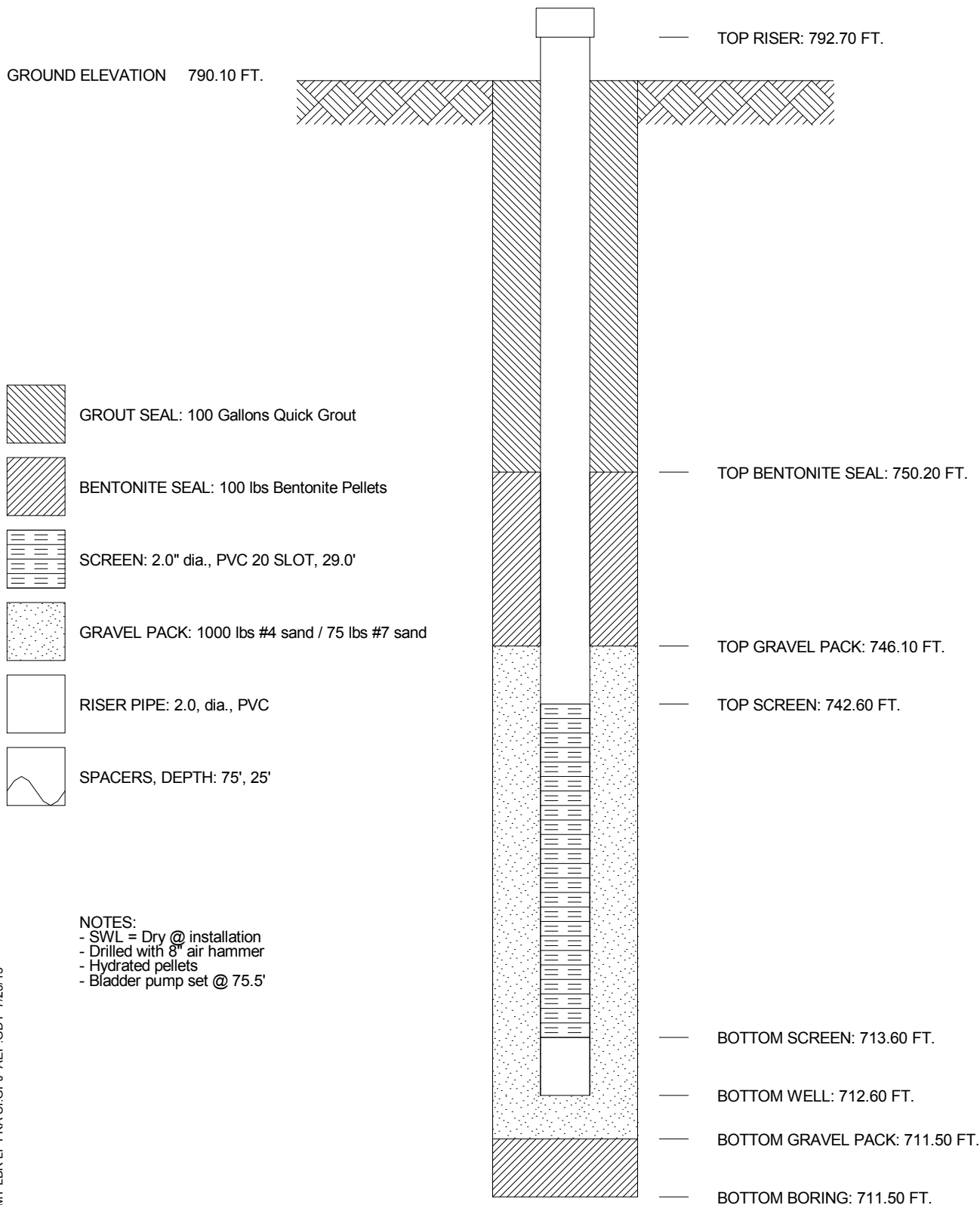







NOTES:
 - SWL = Dry @ installation
 - Drilled with 8" air hammer
 - Hydrated pellets
 - Bladder pump set @ 75.5'

AMERICAN ELECTRIC POWER SERVICE CORPORATION
 AEP CIVIL ENGINEERING LABORATORY
 MONITORING WELL CONSTRUCTION



JOB NUMBER _____
 COMPANY **APPALACHIAN POWER COMPANY** WELL No. **MW-36** BORING No. **MW-36** INSTALLED **7/14/05**
 PROJECT **MOUNTAINEER LBR LANDFILL**
 COORDINATES **N 713,372.6 E 1,733,667.3**
 SYSTEM **State Plane using NAD27**

GROUND ELEVATION 797.60 FT.

-  GROUT SEAL: 75 Gallons Quick Grout
-  BENTONITE SEAL: 100 lbs Bentonite Pellets
-  SCREEN: 2.0" dia., PVC 20 SLOT, 29.0'
-  GRAVEL PACK: 1150 lbs #4 sand / 50 lbs #7 sand
-  RISER PIPE: 2.0, dia., PVC
-  SPACERS, DEPTH: 85', 40'

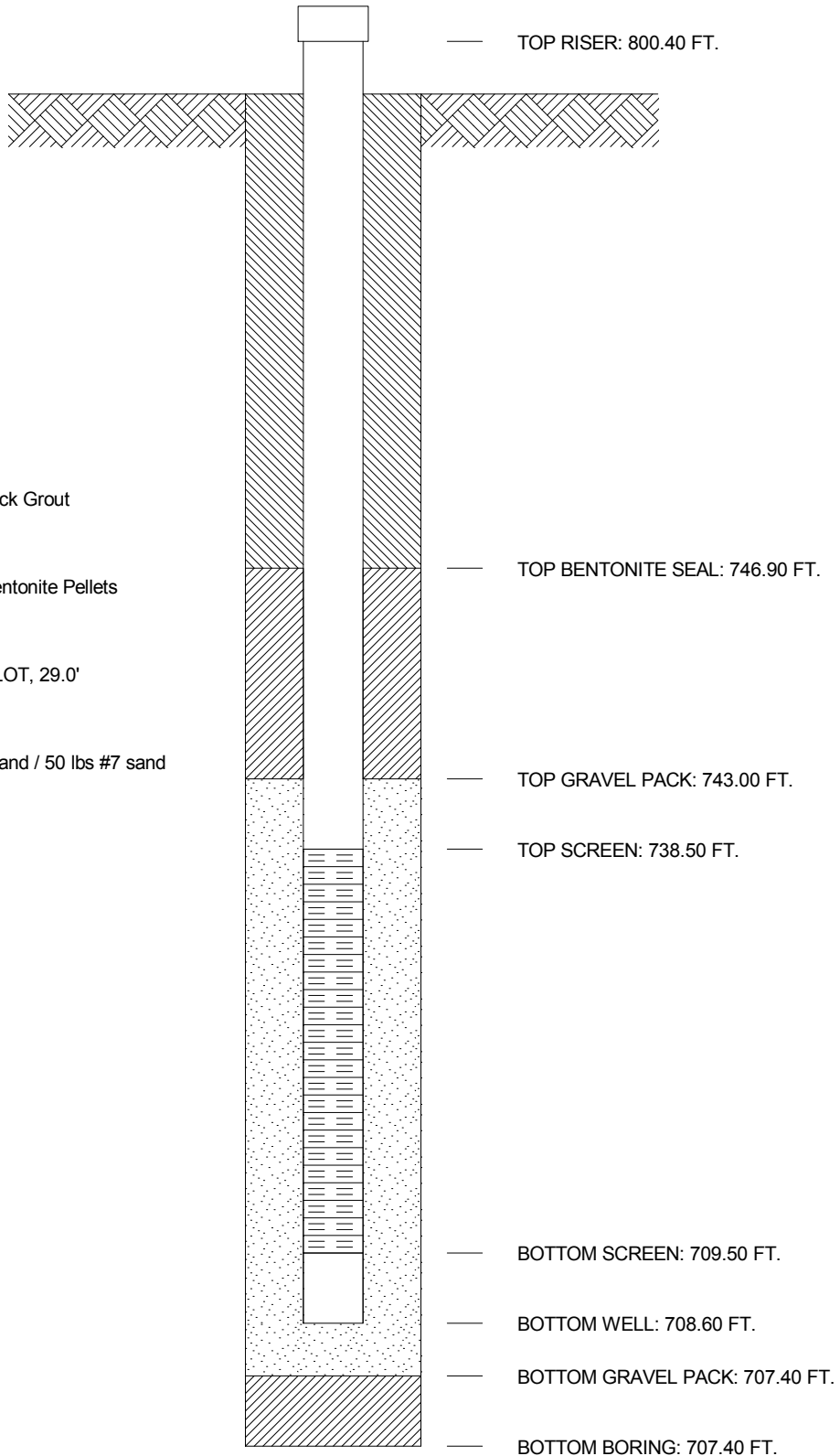

- NOTES:
- SWL = 87.3' @ installation
 - Drilled with 8" air hammer
 - Hydrated pellets
 - Bladder pump set @ 87.0'







AMERICAN ELECTRIC POWER SERVICE CORPORATION
 AEP CIVIL ENGINEERING LABORATORY
 MONITORING WELL CONSTRUCTION

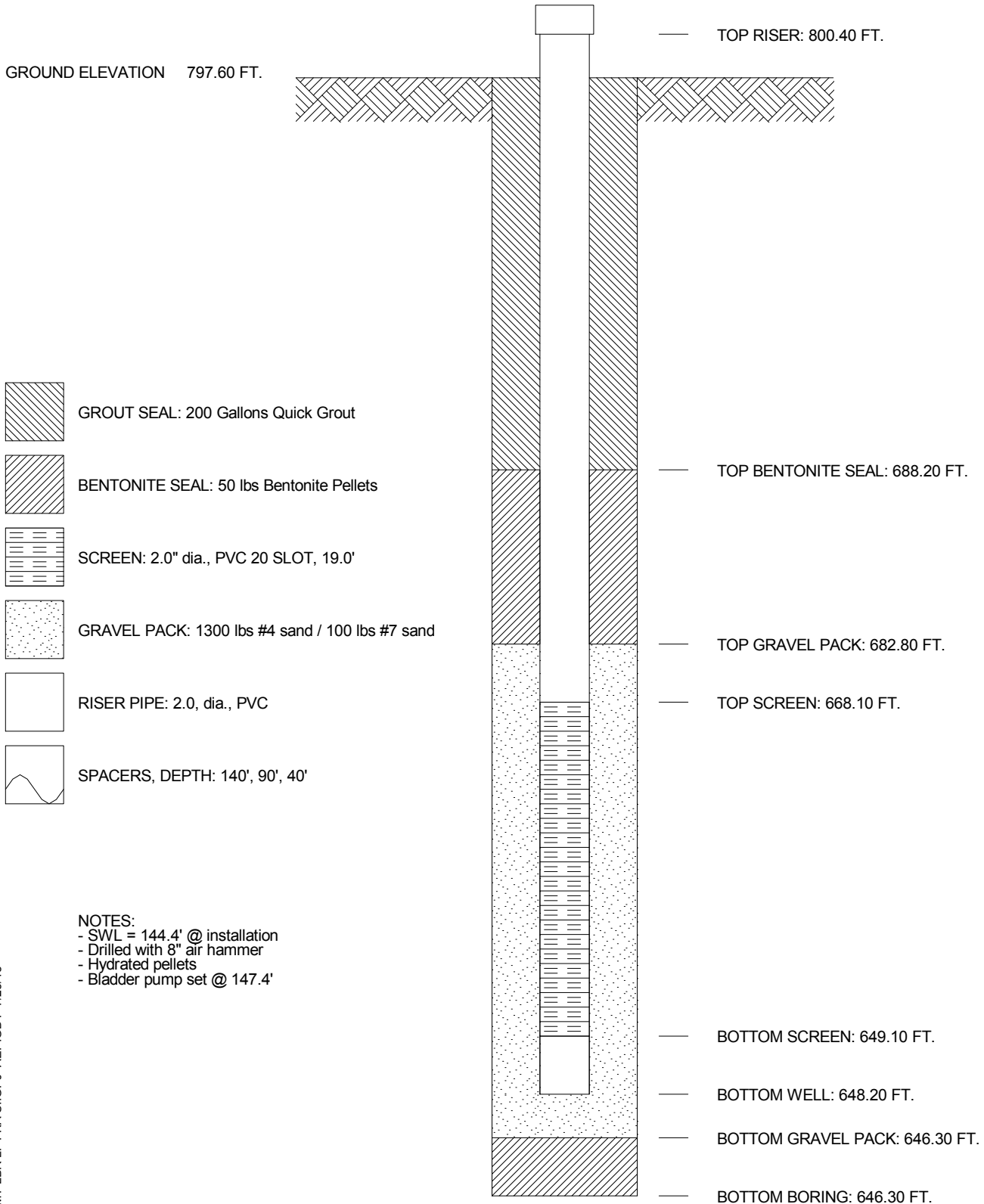

JOB NUMBER _____
 COMPANY **APPALACHIAN POWER COMPANY** WELL No. **MW-37** BORING No. **MW-37** INSTALLED **7/12/05**
 PROJECT **MOUNTAINEER LBR LANDFILL**
 COORDINATES **N 713,377.0 E 1,733,669.5**
 SYSTEM **State Plane using NAD27**

GROUND ELEVATION 797.60 FT.



-  GROUT SEAL: 200 Gallons Quick Grout
-  BENTONITE SEAL: 50 lbs Bentonite Pellets
-  SCREEN: 2.0" dia., PVC 20 SLOT, 19.0'
-  GRAVEL PACK: 1300 lbs #4 sand / 100 lbs #7 sand
-  RISER PIPE: 2.0, dia., PVC
-  SPACERS, DEPTH: 140', 90', 40'







NOTES:
 - SWL = 144.4' @ installation
 - Drilled with 8" air hammer
 - Hydrated pellets
 - Bladder pump set @ 147.4'

AMERICAN ELECTRIC POWER SERVICE CORPORATION
 AEP CIVIL ENGINEERING LABORATORY
 MONITORING WELL CONSTRUCTION



JOB NUMBER _____
 COMPANY **APPALACHIAN POWER COMPANY** WELL No. **MW-38** BORING No. **MW-38** INSTALLED **9/8/05**
 PROJECT **MOUNTAINEER LBR LANDFILL**
 COORDINATES **N 713,736.0 E 1,732,795.5**
 SYSTEM **State Plane using NAD27**

GROUND ELEVATION 627.70 FT.

-  GROUT SEAL: Hole Plug
-  BENTONITE SEAL: 125 lbs Bentonite Pellets
-  SCREEN: 2.0" dia., 15' Prepacked Screen, 20 SLOT, 15.0'
-  GRAVEL PACK: 750 lbs #4 sand / 50 lbs #7 sand
-  RISER PIPE: 2.0, dia., PVC
-  SPACERS, DEPTH: 23'

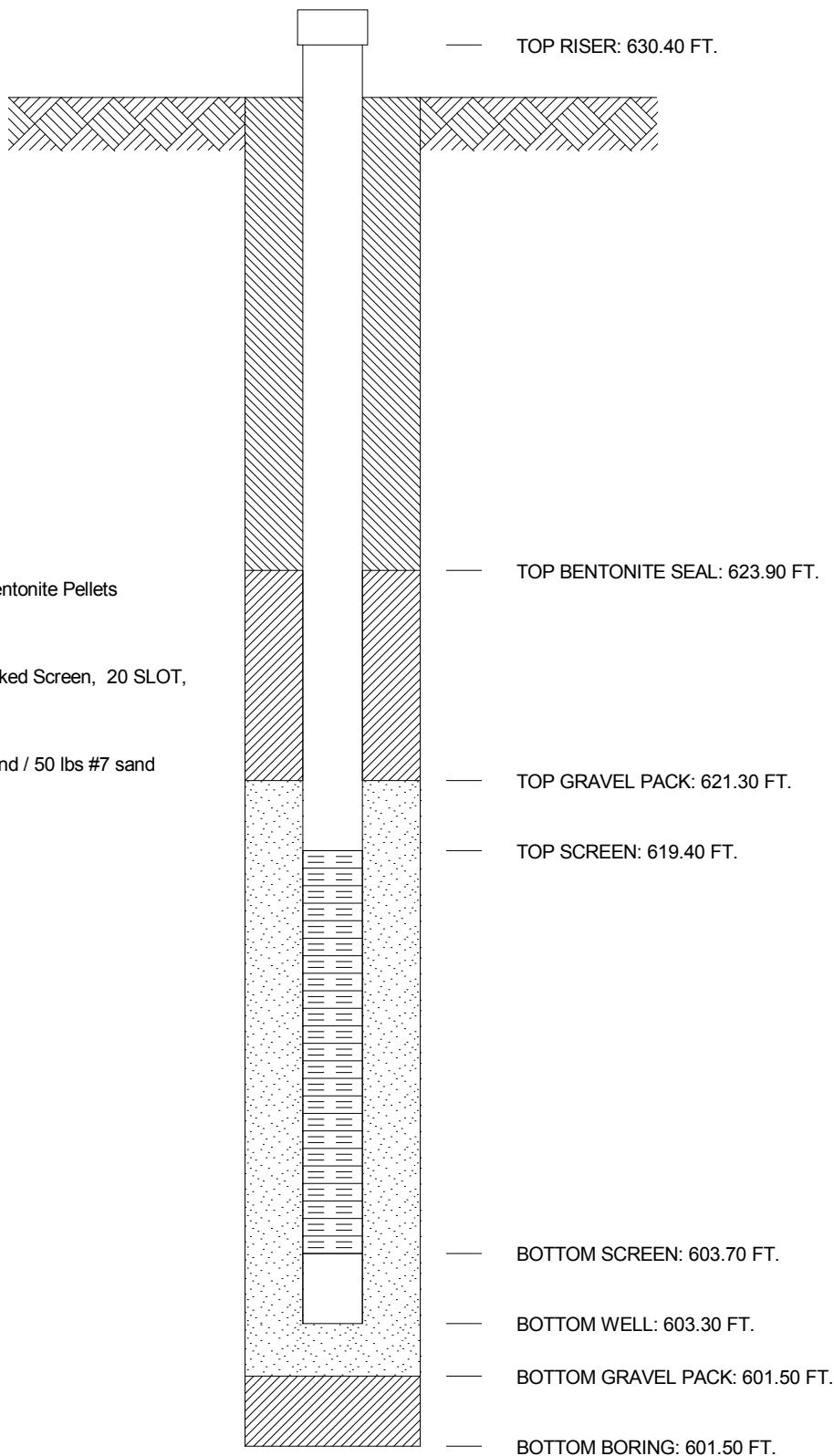

- NOTES:
- SWL = Dry @ installation
 - Drilled with 6.25" HSA's
 - Hydrated pellets
 - Bladder pump set @ 22.4'
 - Hole plug from 3.8' to grade







AMERICAN ELECTRIC POWER SERVICE CORPORATION
 AEP CIVIL ENGINEERING LABORATORY
 MONITORING WELL CONSTRUCTION

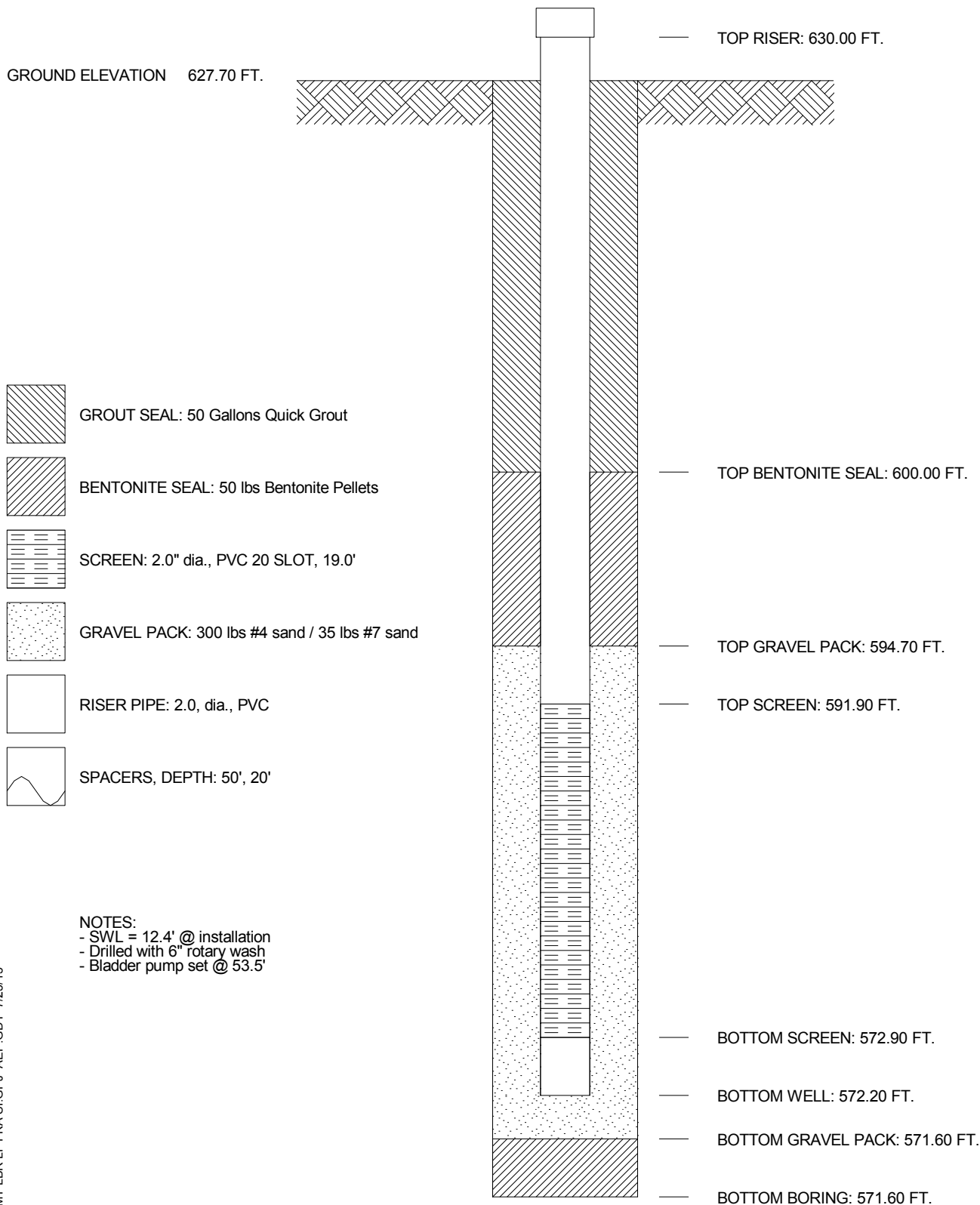

JOB NUMBER _____
 COMPANY **APPALACHIAN POWER COMPANY** WELL No. **MW-39** BORING No. **MW-39** INSTALLED **9/7/05**
 PROJECT **MOUNTAINEER LBR LANDFILL**
 COORDINATES **N 713,734.6 E 1,732,787.2**
 SYSTEM **State Plane using NAD27**

GROUND ELEVATION 627.70 FT.



-  GROUT SEAL: 50 Gallons Quick Grout
-  BENTONITE SEAL: 50 lbs Bentonite Pellets
-  SCREEN: 2.0" dia., PVC 20 SLOT, 19.0'
-  GRAVEL PACK: 300 lbs #4 sand / 35 lbs #7 sand
-  RISER PIPE: 2.0, dia., PVC
-  SPACERS, DEPTH: 50', 20'







NOTES:
 - SWL = 12.4' @ installation
 - Drilled with 6" rotary wash
 - Bladder pump set @ 53.5'

AMERICAN ELECTRIC POWER SERVICE CORPORATION
 AEP CIVIL ENGINEERING LABORATORY
 MONITORING WELL CONSTRUCTION



JOB NUMBER _____
 COMPANY **APPALACHIAN POWER COMPANY** WELL No. **MW-40** BORING No. **MW-40** INSTALLED **9/6/05**
 PROJECT **MOUNTAINEER LBR LANDFILL**
 COORDINATES **N 713,730.4 E 1,732,785.1**
 SYSTEM **State Plane using NAD27**

GROUND ELEVATION 627.70 FT.

-  GROUT SEAL: 150 Gallons Quick Grout
-  BENTONITE SEAL: 80 lbs Bentonite Pellets
-  SCREEN: 2.0" dia., PVC 20 SLOT, 29.0'
-  GRAVEL PACK: 550 lbs #4 sand / 80 lbs #7 sand
-  RISER PIPE: 2.0, dia., PVC
-  SPACERS, DEPTH: 135', 75', 25'

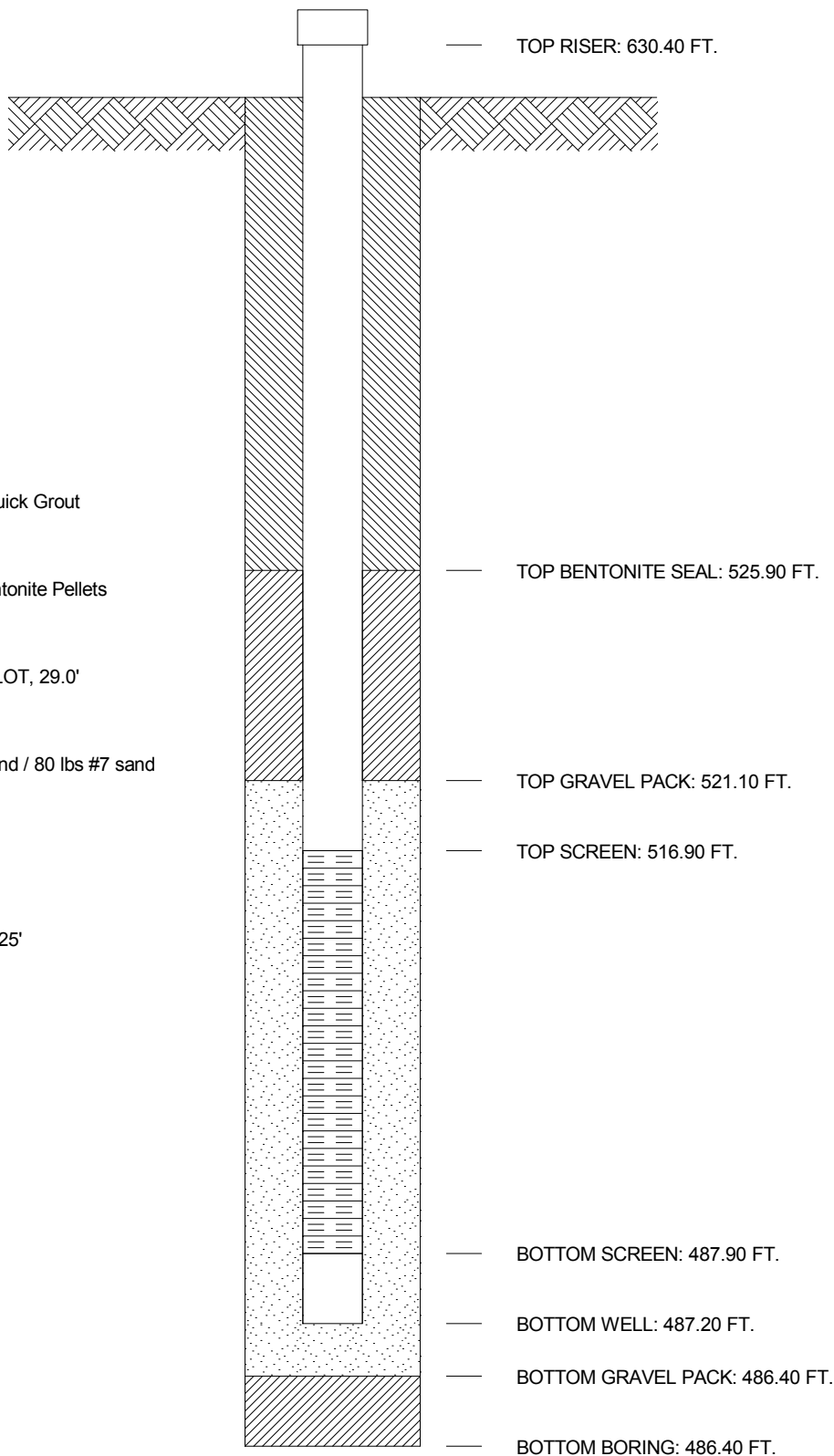







NOTES:
 - SWL = 16.8' @ installation
 - Drilled with 6" rotary wash
 - Bladder pump set @ 138.5'

AMERICAN ELECTRIC POWER SERVICE CORPORATION
 AEP CIVIL ENGINEERING LABORATORY
 MONITORING WELL CONSTRUCTION



JOB NUMBER _____
 COMPANY **APPALACHIAN POWER COMPANY** WELL No. **MW-41** BORING No. **MW-41** INSTALLED **8/1/05**
 PROJECT **MOUNTAINEER LBR LANDFILL**
 COORDINATES **N 713,381.3 E 1,733,671.6**
 SYSTEM **State Plane using NAD27**

GROUND ELEVATION 797.60 FT.

-  GROUT SEAL: 200 Gallons Quick Grout
-  BENTONITE SEAL: 40 lbs Bentonite Pellets
-  SCREEN: 1.0" dia., 1" Geomon, 20 SLOT, 2.0'
-  GRAVEL PACK: 250 lbs #4 sand / 50 lbs #7 sand
-  RISER PIPE: , dia.,
-  SPACERS, DEPTH:

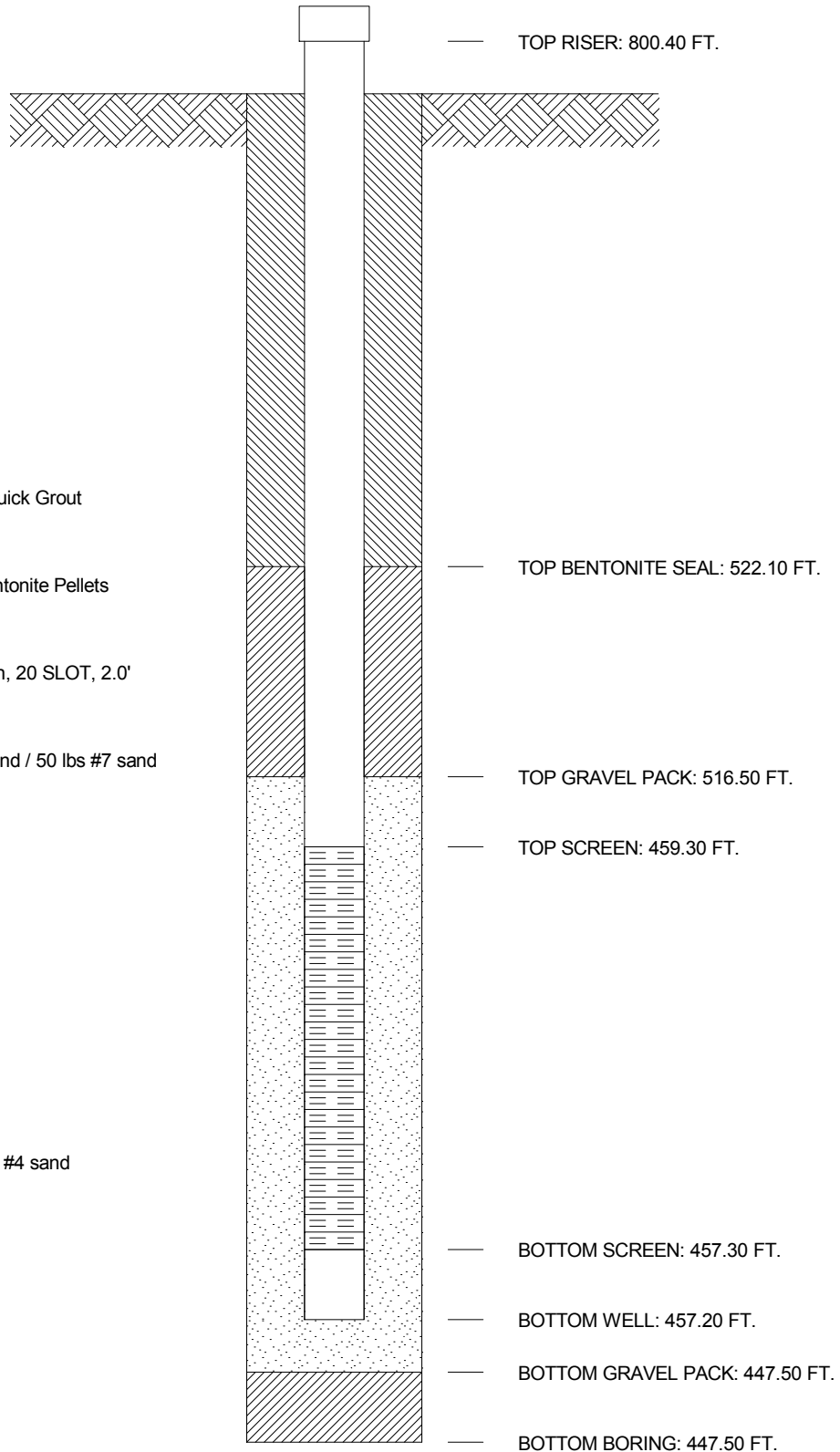

- NOTES:
- SWL = NA @ installation
 - Drilled with NQ Rock Core
 - Bottom of hole backfilled with #4 sand

AMERICAN ELECTRIC POWER SERVICE CORPORATION
 AEP CIVIL ENGINEERING LABORATORY
 MONITORING WELL CONSTRUCTION



JOB NUMBER _____
 COMPANY **APPALACHIAN POWER COMPANY** WELL No. **MW-42** BORING No. **MW-42** INSTALLED **9/8/05**
 PROJECT **MOUNTAINEER LBR LANDFILL**
 COORDINATES **N 713,726.5 E 1,732,783.6**
 SYSTEM **State Plane using NAD27**

GROUND ELEVATION 627.70 FT.

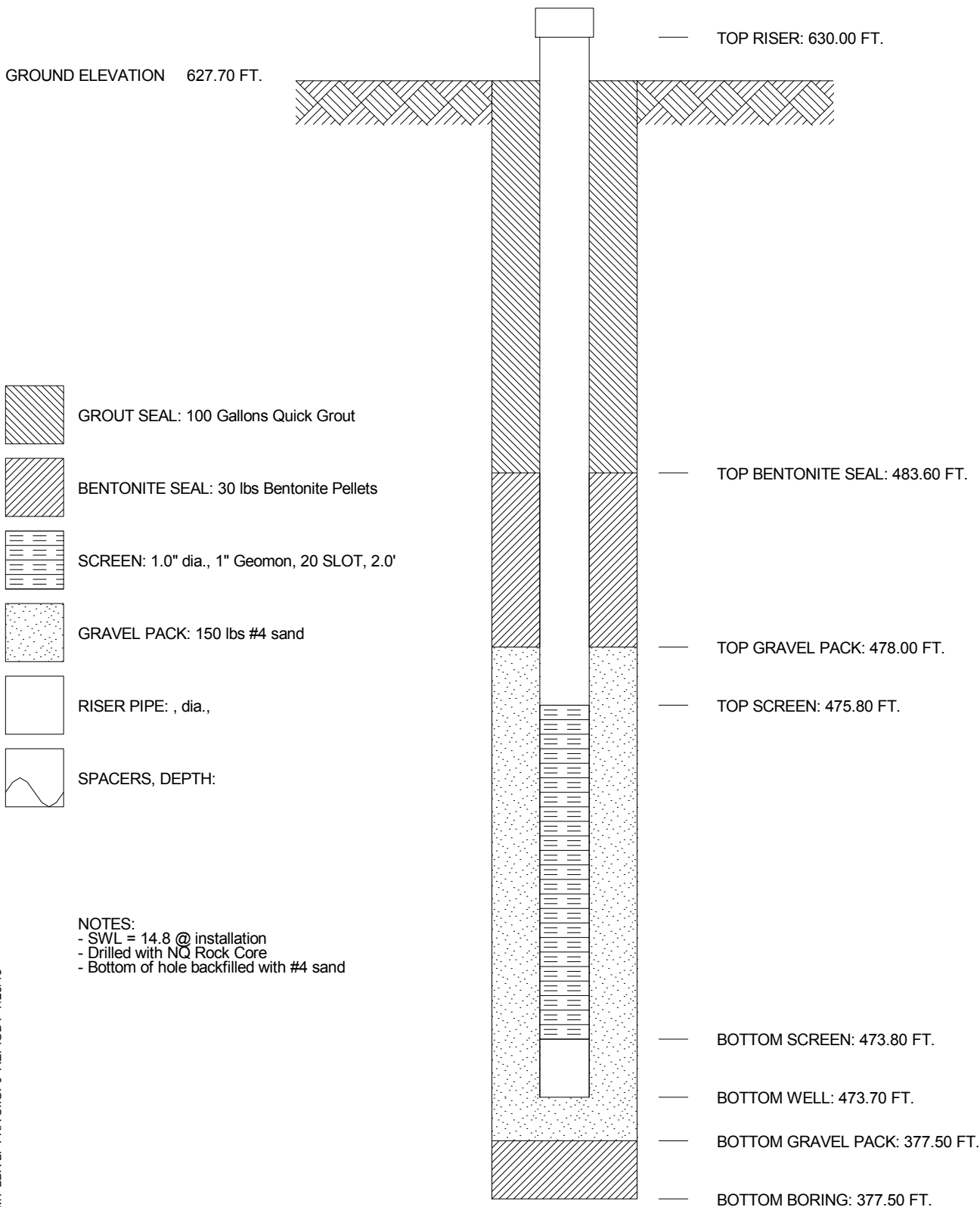

NOTES:
 - SWL = 14.8 @ installation
 - Drilled with NQ Rock Core
 - Bottom of hole backfilled with #4 sand







AMERICAN ELECTRIC POWER SERVICE CORPORATION
 AEP CIVIL ENGINEERING LABORATORY
 MONITORING WELL CONSTRUCTION

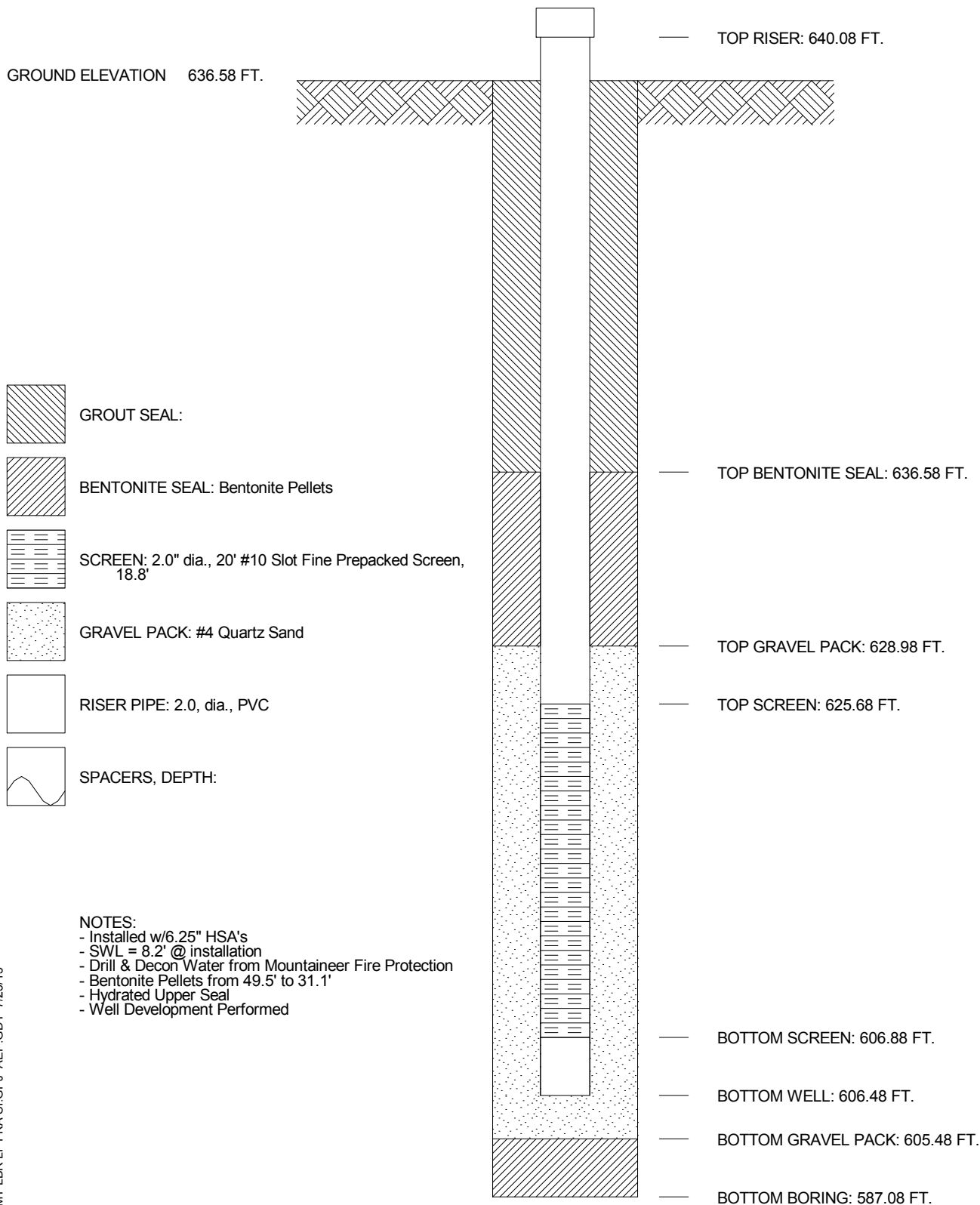

JOB NUMBER _____
 COMPANY **APPALACHIAN POWER COMPANY** WELL No. **MW-43** BORING No. **MW-43** INSTALLED **7/12/06**
 PROJECT **MOUNTAINEER LBR LANDFILL**
 COORDINATES **N 714,609.8 E 1,733,558.2**
 SYSTEM **State Plane using NAD27/29**

GROUND ELEVATION 636.58 FT.



-  GROUT SEAL:
-  BENTONITE SEAL: Bentonite Pellets
-  SCREEN: 2.0" dia., 20' #10 Slot Fine Prepacked Screen, 18.8'
-  GRAVEL PACK: #4 Quartz Sand
-  RISER PIPE: 2.0, dia., PVC
-  SPACERS, DEPTH:

- NOTES:
- Installed w/6.25" HSA's
 - SWL = 8.2' @ installation
 - Drill & Decon Water from Mountaineer Fire Protection
 - Bentonite Pellets from 49.5' to 31.1'
 - Hydrated Upper Seal
 - Well Development Performed

AMERICAN ELECTRIC POWER SERVICE CORPORATION
 AEP CIVIL ENGINEERING LABORATORY
 MONITORING WELL CONSTRUCTION



JOB NUMBER _____
 COMPANY **APPALACHIAN POWER COMPANY** WELL No. _____ BORING No. **MW-44** INSTALLED **6/10/08**
 PROJECT **MOUNTAINEER LBR LANDFILL**
 COORDINATES **N 714,697.9 E 1,733,351.5**
 SYSTEM **State Plane using NAD27**

GROUND ELEVATION 624.49 FT.

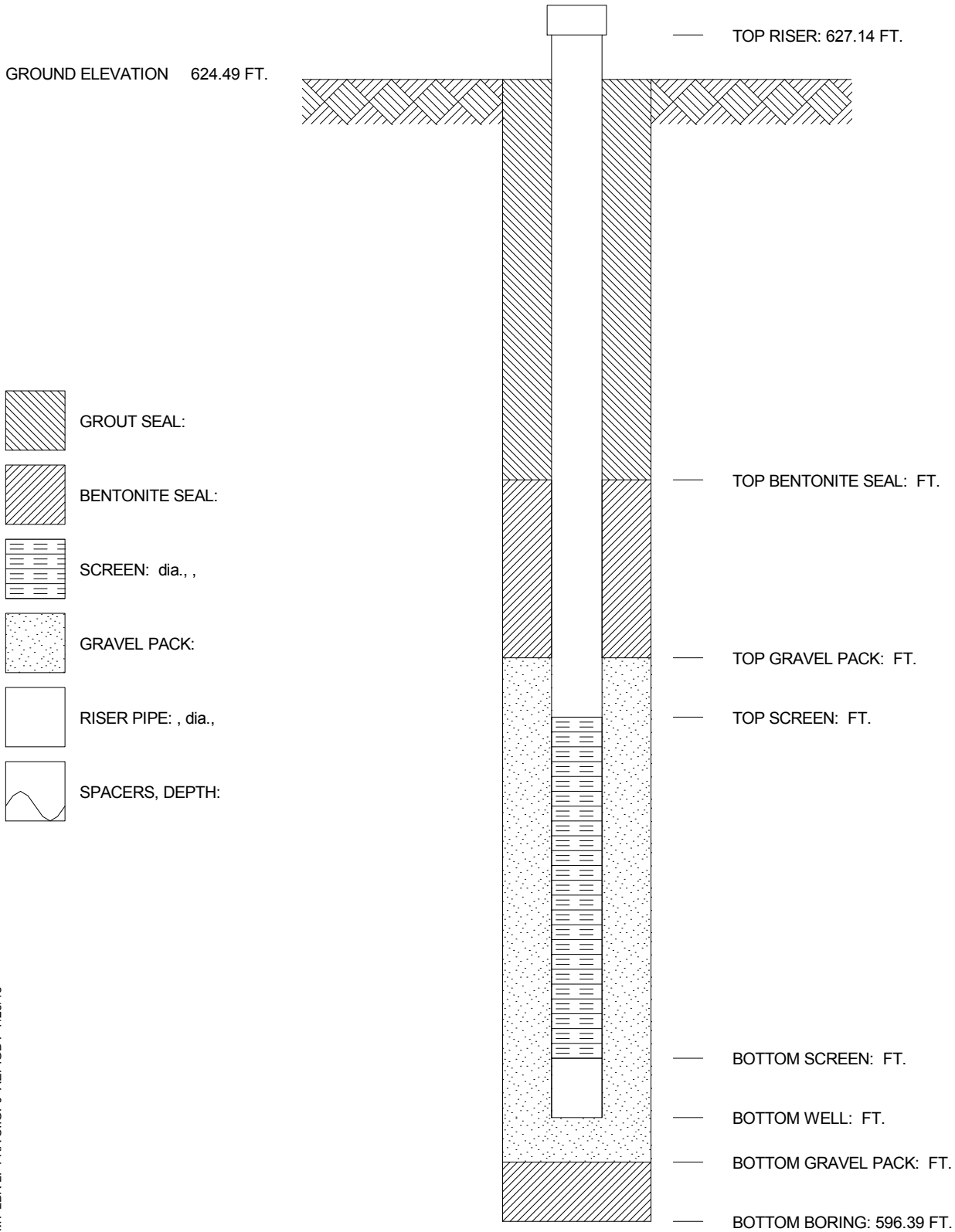

AMERICAN ELECTRIC POWER SERVICE CORPORATION
 AEP CIVIL ENGINEERING LABORATORY
 MONITORING WELL CONSTRUCTION



JOB NUMBER _____
 COMPANY APPALACHIAN POWER COMPANY WELL No. MW-44D BORING No. MW-44D INSTALLED 6/18/08
 PROJECT MOUNTAINEER LBR LANDFILL
 COORDINATES N 714,697.9 E 1,733,351.5
 SYSTEM State Plane using NAD27

GROUND ELEVATION 624.49 FT.

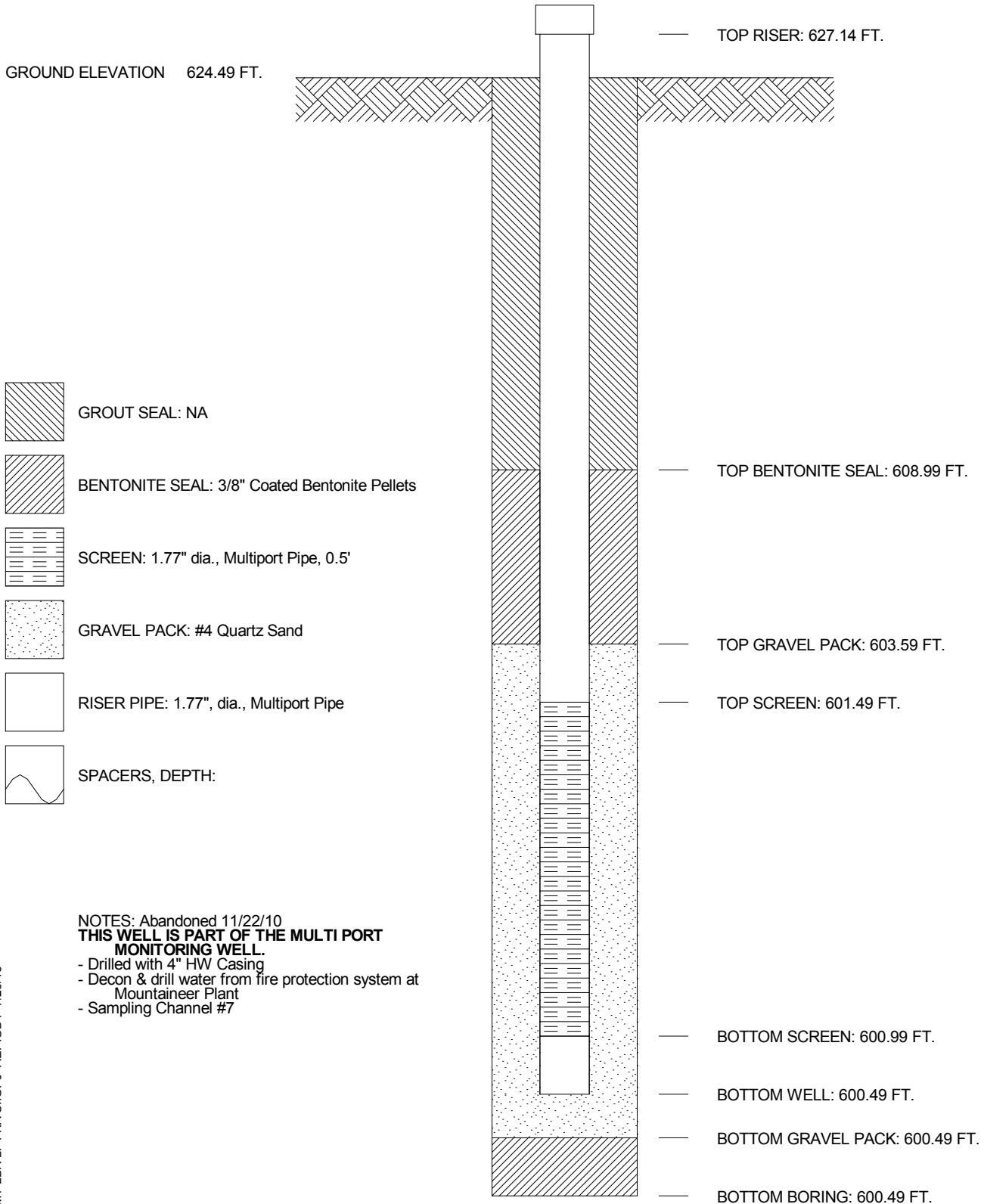

NOTES: Abandoned 11/22/10
THIS WELL IS PART OF THE MULTI PORT MONITORING WELL.
 - Drilled with 4" HW Casing
 - Decon & drill water from fire protection system at Mountaineer Plant
 - Sampling Channel #7

AMERICAN ELECTRIC POWER SERVICE CORPORATION
 AEP CIVIL ENGINEERING LABORATORY
 MONITORING WELL CONSTRUCTION



JOB NUMBER _____
 COMPANY **APPALACHIAN POWER COMPANY** WELL No. **MW-44I** BORING No. **MW-44I** INSTALLED **6/18/08**
 PROJECT **MOUNTAINEER LBR LANDFILL**
 COORDINATES **N 714,697.9 E 1,733,351.5**
 SYSTEM **State Plane using NAD27**

GROUND ELEVATION 624.49 FT.

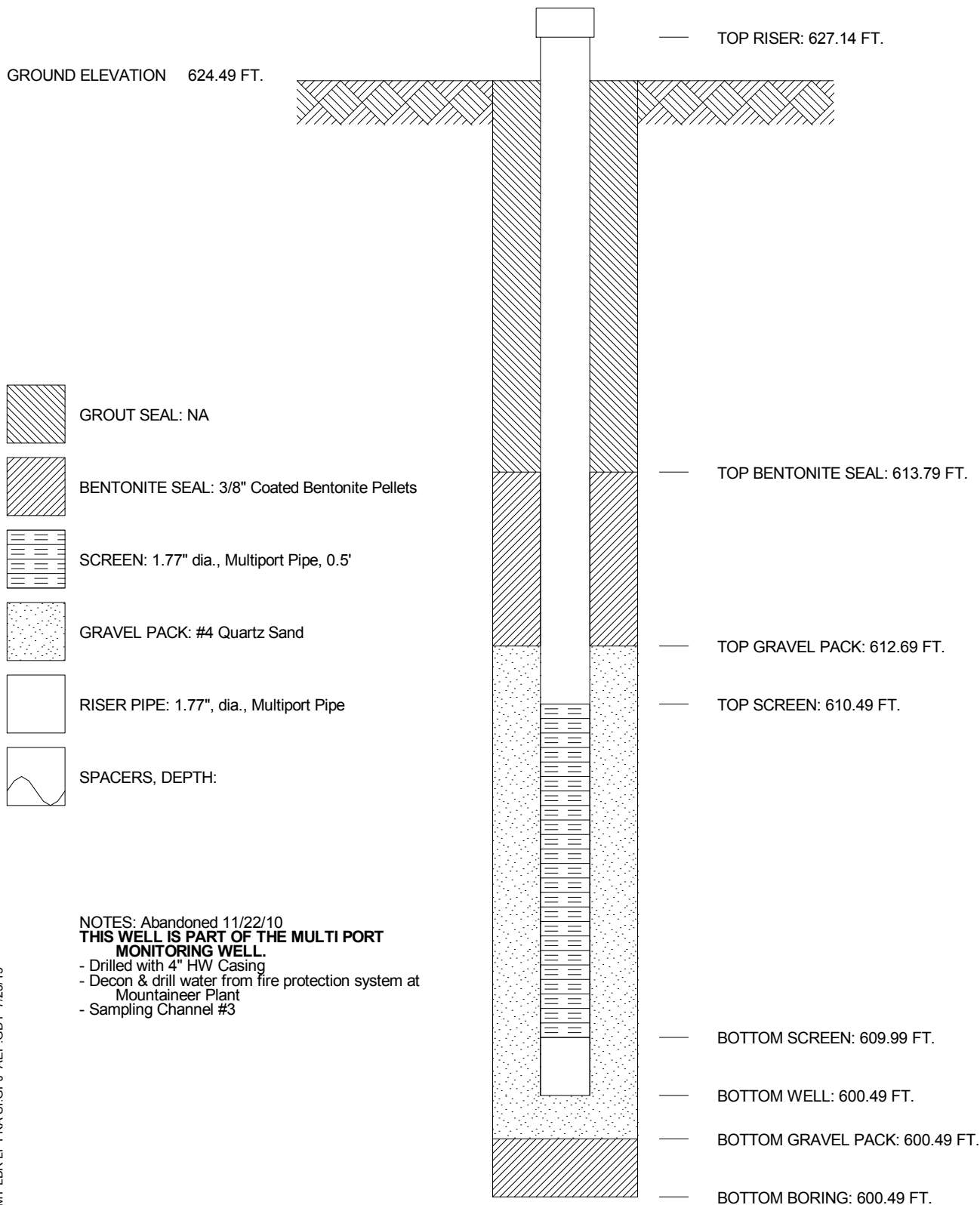

NOTES: Abandoned 11/22/10
THIS WELL IS PART OF THE MULTI PORT MONITORING WELL.
 - Drilled with 4" HW Casing
 - Decon & drill water from fire protection system at Mountaineer Plant
 - Sampling Channel #3







AMERICAN ELECTRIC POWER SERVICE CORPORATION
 AEP CIVIL ENGINEERING LABORATORY
 MONITORING WELL CONSTRUCTION

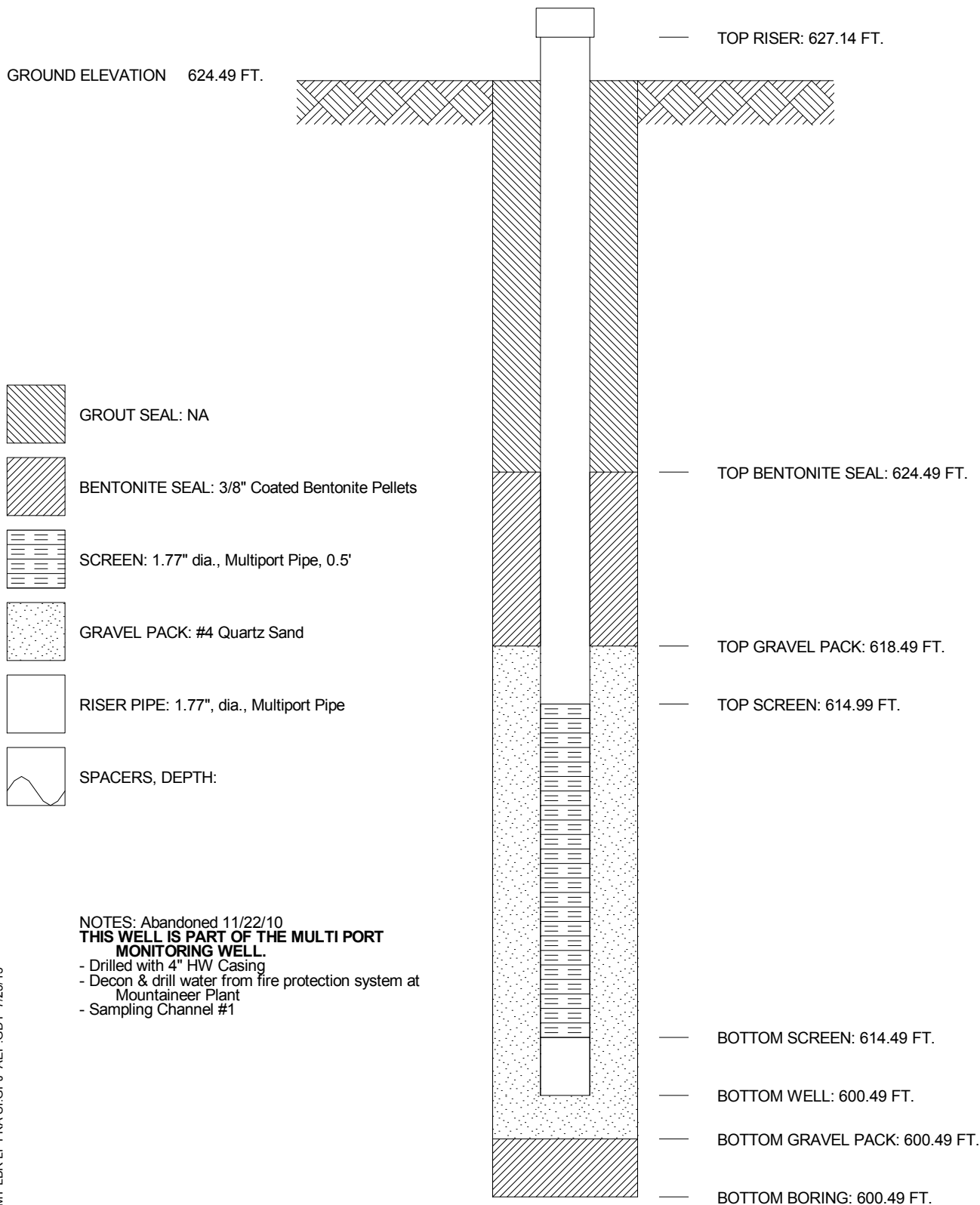

JOB NUMBER _____
 COMPANY **APPALACHIAN POWER COMPANY** WELL No. **MW-44S** BORING No. **MW-44S** INSTALLED **6/18/08**
 PROJECT **MOUNTAINEER LBR LANDFILL**
 COORDINATES **N 714,697.9 E 1,733,351.5**
 SYSTEM **State Plane using NAD27**

GROUND ELEVATION 624.49 FT.



-  GROUT SEAL: NA
-  BENTONITE SEAL: 3/8" Coated Bentonite Pellets
-  SCREEN: 1.77" dia., Multiport Pipe, 0.5'
-  GRAVEL PACK: #4 Quartz Sand
-  RISER PIPE: 1.77", dia., Multiport Pipe
-  SPACERS, DEPTH:

NOTES: Abandoned 11/22/10
THIS WELL IS PART OF THE MULTI PORT MONITORING WELL.
 - Drilled with 4" HW Casing
 - Decon & drill water from fire protection system at Mountaineer Plant
 - Sampling Channel #1



AEP 1996, 1997

**Monitoring Well Construction
Diagrams**







9623, 9624, 9627 to 9633

AMERICAN ELECTRIC POWER SERVICE CORPORATION
 AEP CIVIL ENGINEERING LABORATORY
 MONITORING WELL CONSTRUCTION



JOB NUMBER _____
 COMPANY **APPALACHIAN POWER COMPANY** WELL No. **9623** BORING No. **96-23** INSTALLED **10/15/96**
 PROJECT **MOUNTAINEER LBR LANDFILL**
 COORDINATES **N 708,450.6 E 1,698,953.5**
 SYSTEM _____

GROUND ELEVATION 690.45 FT.

-  GROUT SEAL: 400 GALLONS QUICK GROUT
-  BENTONITE SEAL: 120# BENTONITE CHIPS
-  SCREEN: 2.0 dia., PVC SCH 40 20 SLOT, 19.1
-  GRAVEL PACK: 700# No.4 OHIO QUARTZ
-  RISER PIPE: 2.0, dia., PVC SCH 40
-  SPACERS, DEPTH: 110', 90', 40'

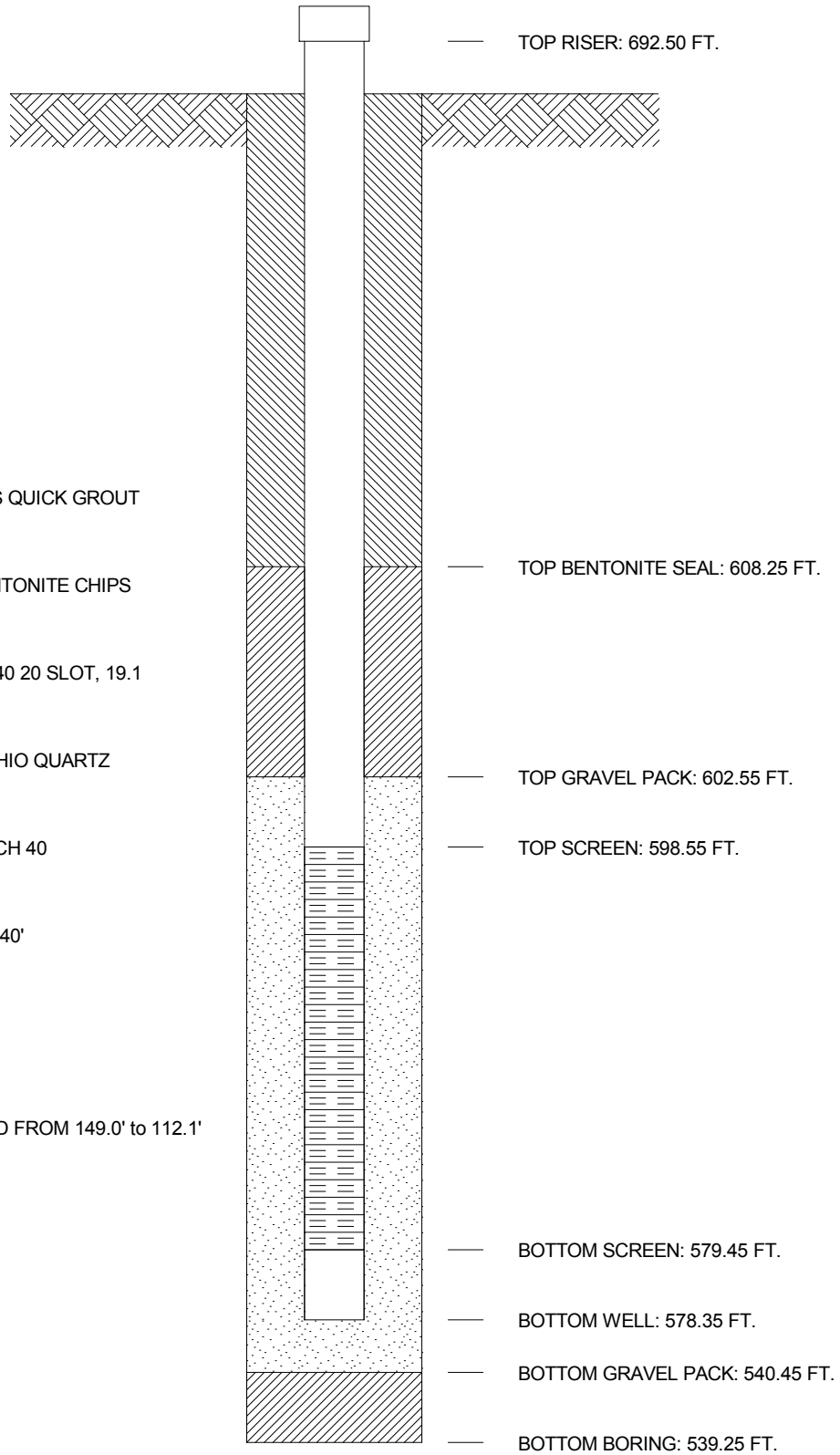

SWL @ COMPLETION - 32.0'
 90# BENTONITE CHIPS USED FROM 149.0' to 112.1'

AMERICAN ELECTRIC POWER SERVICE CORPORATION
 AEP CIVIL ENGINEERING LABORATORY
 MONITORING WELL CONSTRUCTION



JOB NUMBER _____
 COMPANY **APPALACHIAN POWER COMPANY**
 PROJECT **MOUNTAINEER LBR LANDFILL**
 COORDINATES **N 709,245.0 E 1,732,142.0**
 SYSTEM _____

WELL No. _____ BORING No. **96-24** INSTALLED **9/23/96**

GROUND ELEVATION 825.49 FT.

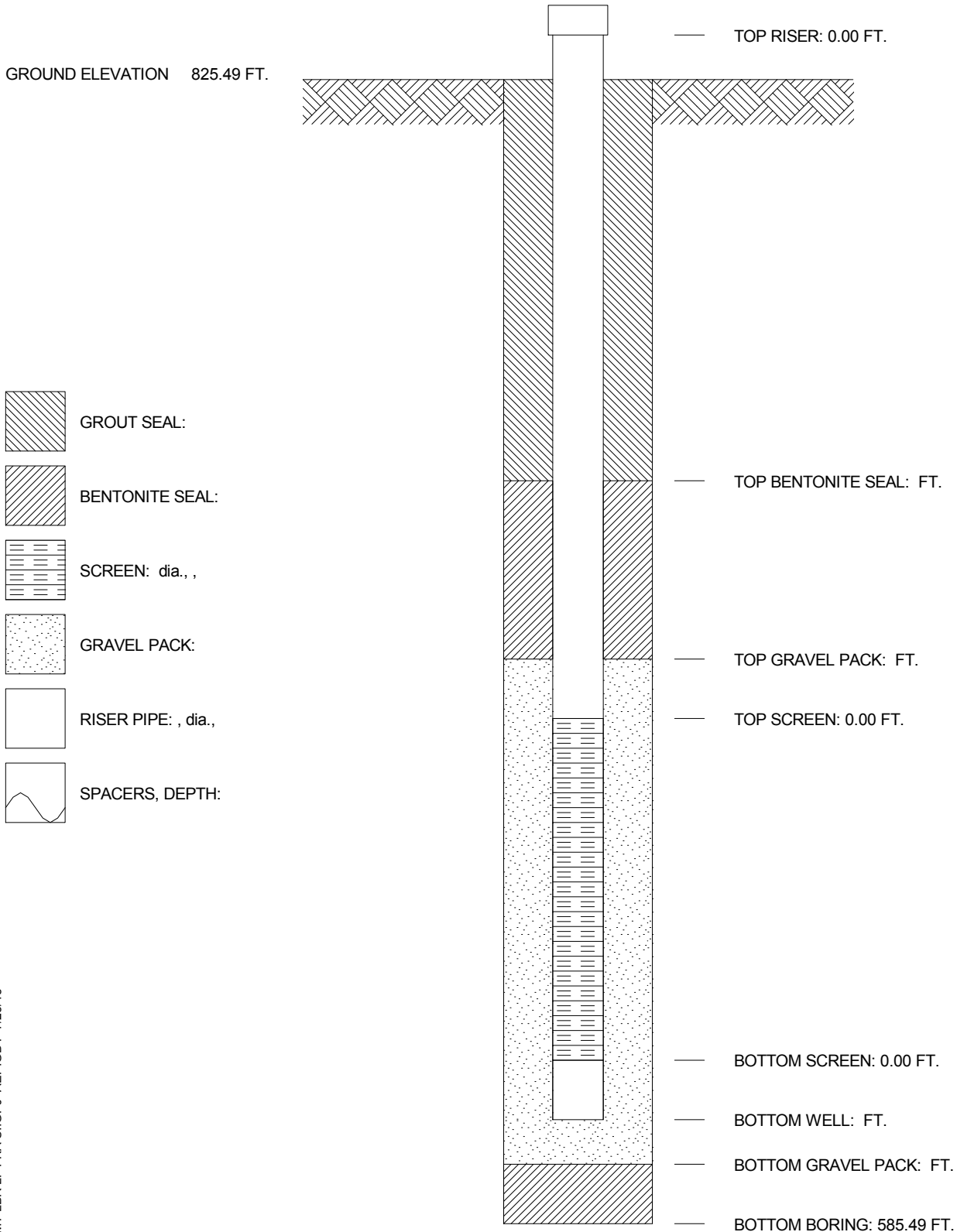







AMERICAN ELECTRIC POWER SERVICE CORPORATION
 AEP CIVIL ENGINEERING LABORATORY
 MONITORING WELL CONSTRUCTION



JOB NUMBER _____
 COMPANY **APPALACHIAN POWER COMPANY**
 PROJECT **MOUNTAINEER LBR LANDFILL**
 COORDINATES **N 712,597.9 E 1,699,973.8**
 SYSTEM _____

WELL No. **9627** BORING No. **96-27** INSTALLED **10/9/96**

GROUND ELEVATION 718.06 FT.

-  GROUT SEAL: 350 GALLONS QUICK GROUT
-  BENTONITE SEAL: 150# BENTONITE CHIPS
-  SCREEN: 2.0 dia., PVC SCH 40 20 SLOT, 19.0
-  GRAVEL PACK: 650# No. 4 OHIO QUARTZ
-  RISER PIPE: 2.0, dia., PVC SCH 40
-  SPACERS, DEPTH: 130', 110', 60

SWL @ COMPLETION - 99.8'

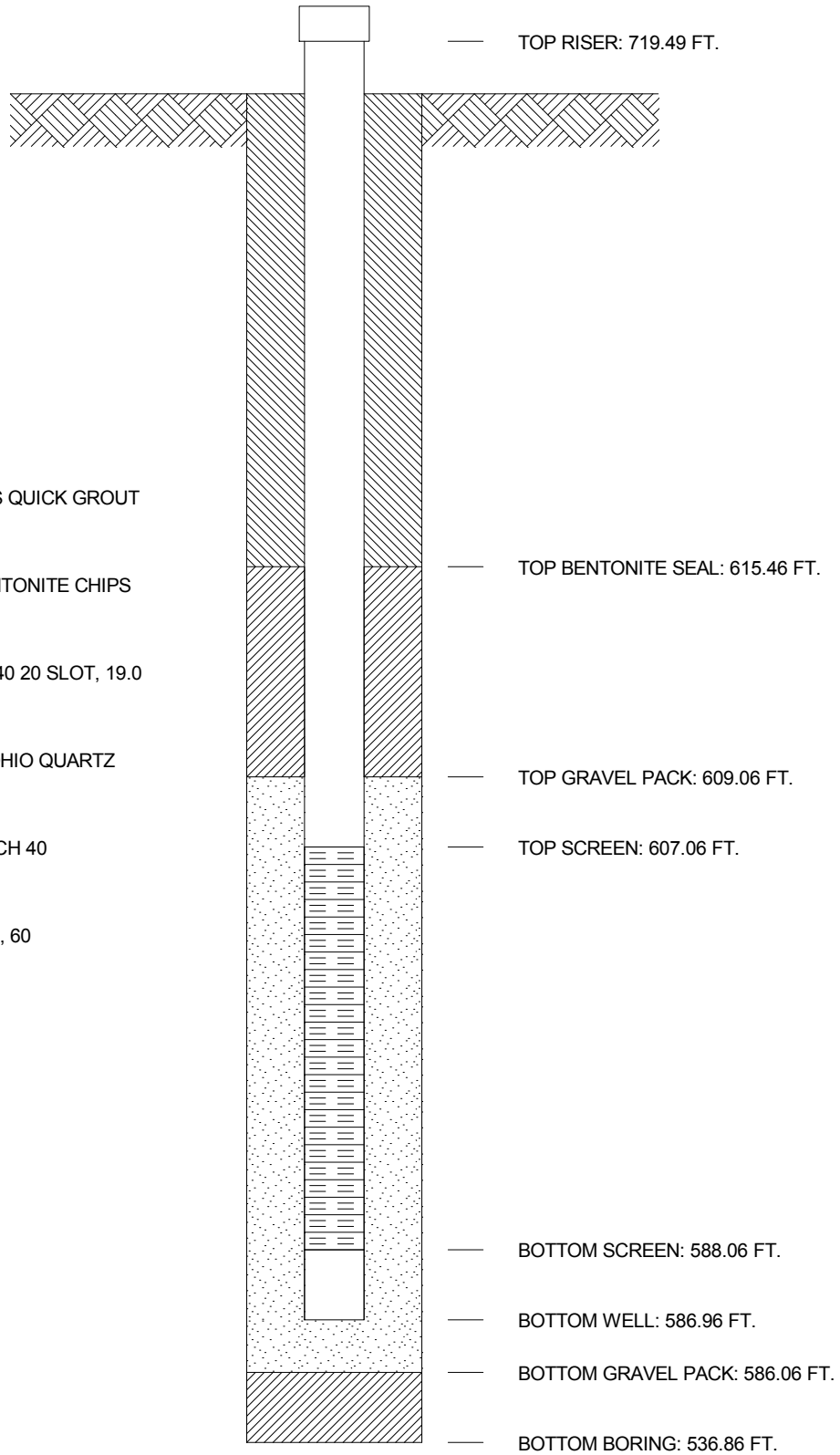

AMERICAN ELECTRIC POWER SERVICE CORPORATION
 AEP CIVIL ENGINEERING LABORATORY
 MONITORING WELL CONSTRUCTION







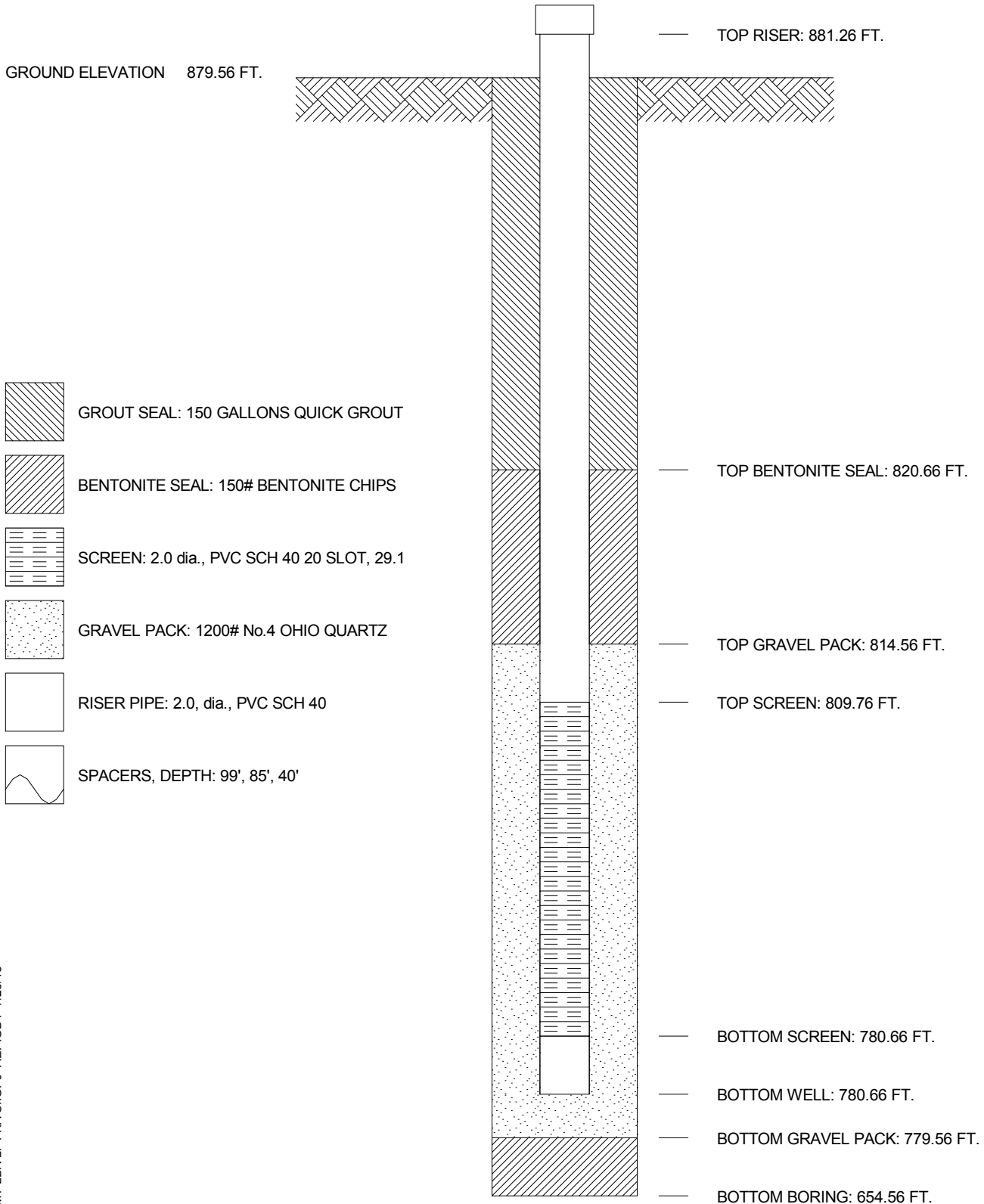

JOB NUMBER _____
 COMPANY **APPALACHIAN POWER COMPANY**
 PROJECT **MOUNTAINEER LBR LANDFILL**
 COORDINATES **N 708,701.0 E 1,697,043.0**
 SYSTEM _____

WELL No. **9628** BORING No. **96-28** INSTALLED **12/10/96**

GROUND ELEVATION 879.56 FT.



-  GROUT SEAL: 150 GALLONS QUICK GROUT
-  BENTONITE SEAL: 150# BENTONITE CHIPS
-  SCREEN: 2.0 dia., PVC SCH 40 20 SLOT, 29.1
-  GRAVEL PACK: 1200# No.4 OHIO QUARTZ
-  RISER PIPE: 2.0, dia., PVC SCH 40
-  SPACERS, DEPTH: 99', 85', 40'

AMERICAN ELECTRIC POWER SERVICE CORPORATION
 AEP CIVIL ENGINEERING LABORATORY
 MONITORING WELL CONSTRUCTION







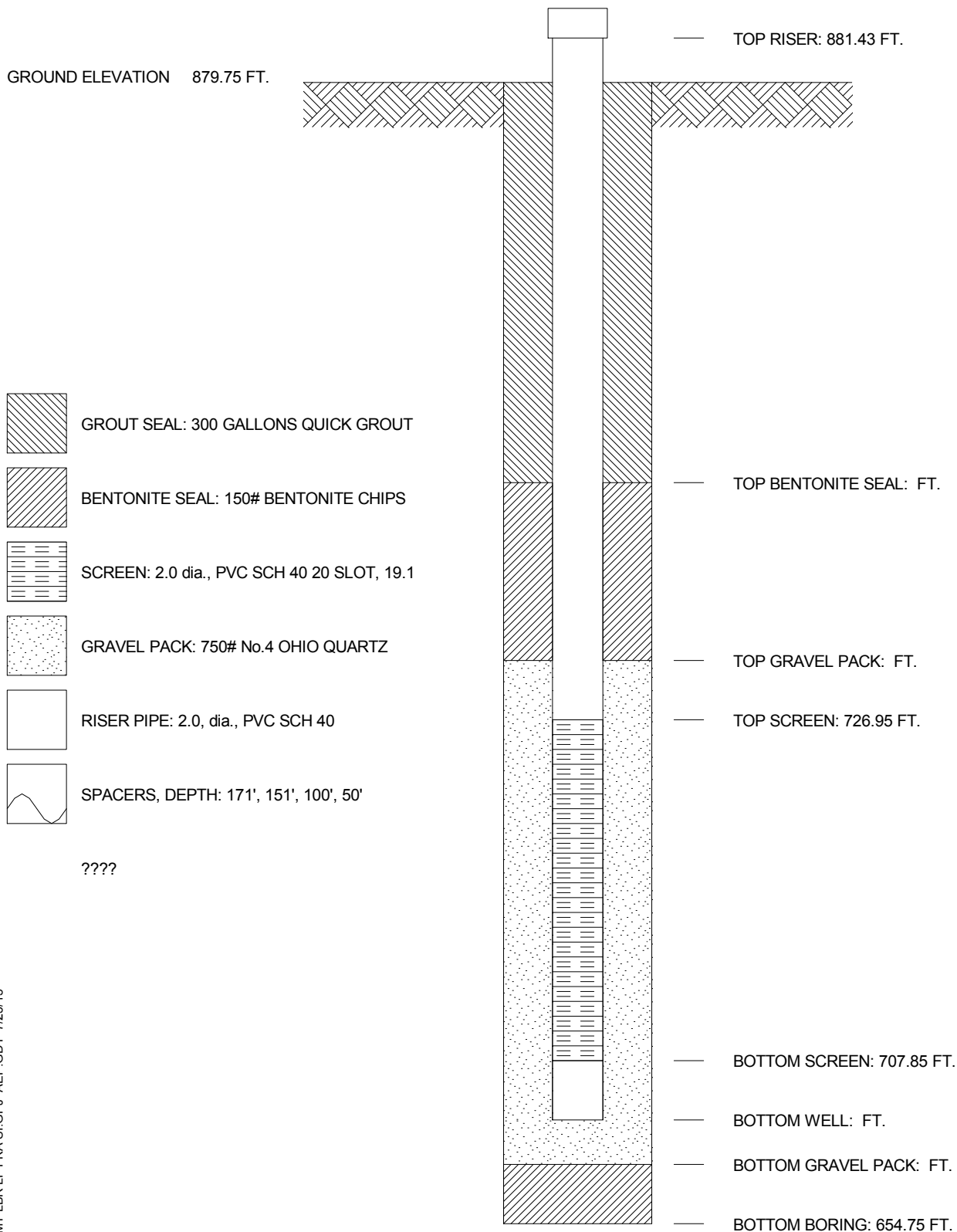

JOB NUMBER _____
 COMPANY **APPALACHIAN POWER COMPANY**
 PROJECT **MOUNTAINEER LBR LANDFILL**
 COORDINATES **N 708,701.2 E 1,697,043.2**
 SYSTEM _____

WELL No. **9629** BORING No. **96-29** INSTALLED **12/4/96**

GROUND ELEVATION 879.75 FT.



-  GROUT SEAL: 300 GALLONS QUICK GROUT
-  BENTONITE SEAL: 150# BENTONITE CHIPS
-  SCREEN: 2.0 dia., PVC SCH 40 20 SLOT, 19.1
-  GRAVEL PACK: 750# No.4 OHIO QUARTZ
-  RISER PIPE: 2.0, dia., PVC SCH 40
-  SPACERS, DEPTH: 171', 151', 100', 50'







????

AMERICAN ELECTRIC POWER SERVICE CORPORATION
 AEP CIVIL ENGINEERING LABORATORY
 MONITORING WELL CONSTRUCTION



JOB NUMBER _____
 COMPANY **APPALACHIAN POWER COMPANY** WELL No. **9630** BORING No. **96-30** INSTALLED **9/11/96**
 PROJECT **MOUNTAINEER LBR LANDFILL**
 COORDINATES **N 708,701.0 E 1,697,043.0**
 SYSTEM _____

GROUND ELEVATION 879.83 FT.

-  GROUT SEAL: 500 GALLONS QUICK GROUT
-  BENTONITE SEAL: 150# BENTONITE CHIPS
-  SCREEN: 2.0 dia., PVC SCH 40 20 SLOT, 21.9
-  GRAVEL PACK: 1000# No.4 OHIO QUARTZ
-  RISER PIPE: 2.0, dia., PVC SCH 40
-  SPACERS, DEPTH: 225' 210' 156' 106' 40'

????

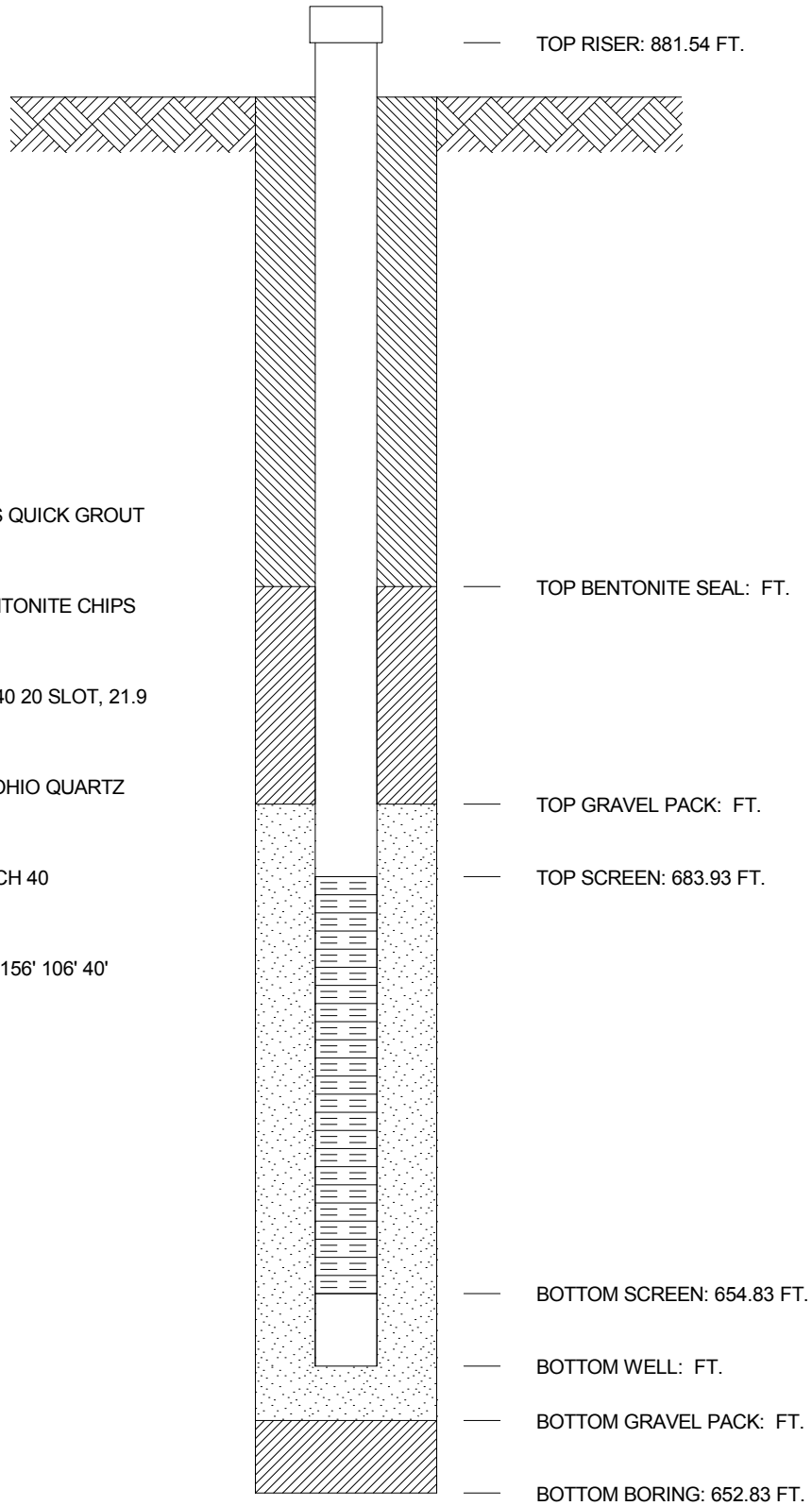

AMERICAN ELECTRIC POWER SERVICE CORPORATION
 AEP CIVIL ENGINEERING LABORATORY
 MONITORING WELL CONSTRUCTION



JOB NUMBER _____
 COMPANY **APPALACHIAN POWER COMPANY**
 PROJECT **MOUNTAINEER LBR LANDFILL**
 COORDINATES **N 711,108.2 E 1,696,404.8**
 SYSTEM _____

WELL No. **9631** BORING No. **96-31** INSTALLED **9/12/96**

GROUND ELEVATION 826.56 FT.

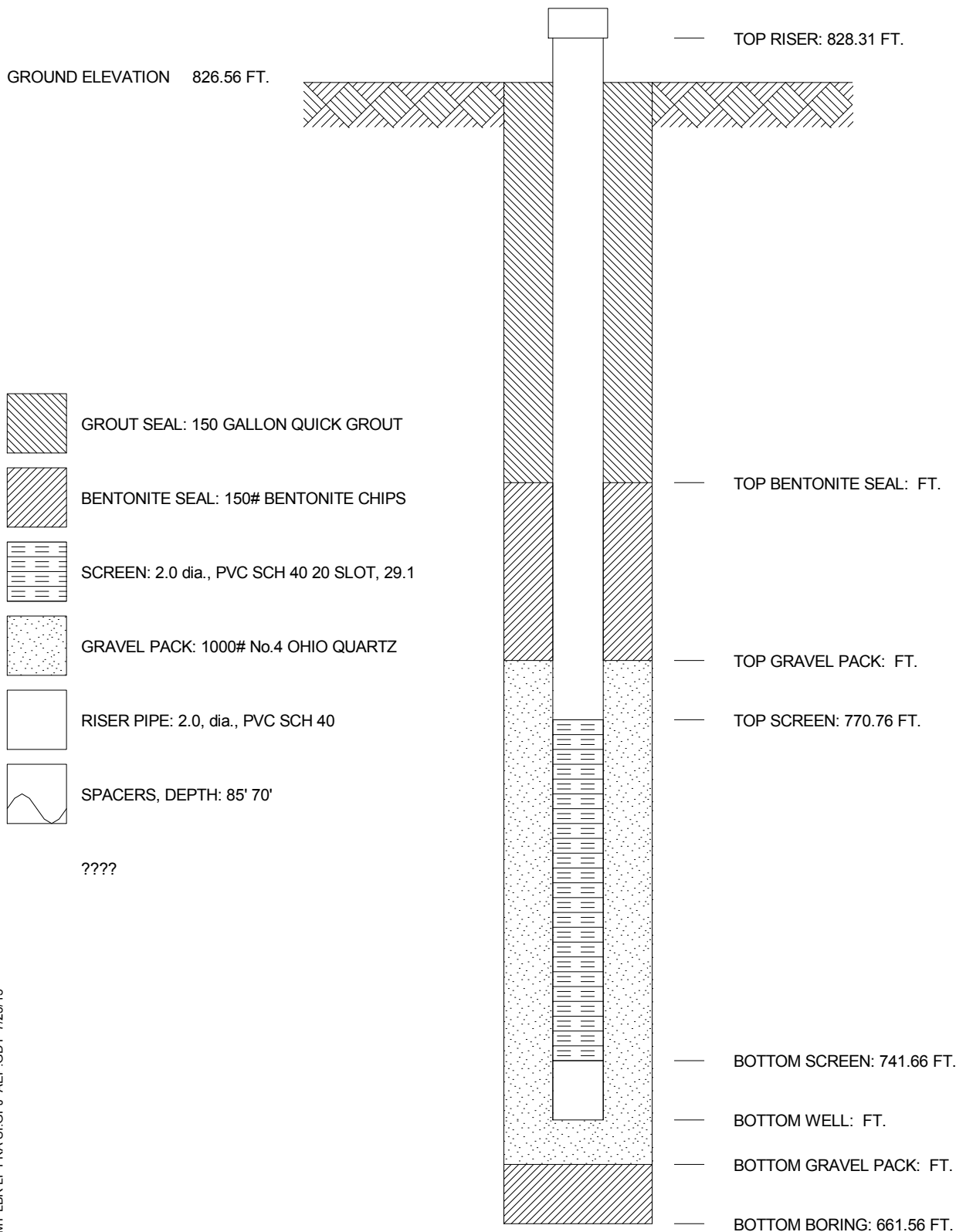

AMERICAN ELECTRIC POWER SERVICE CORPORATION
 AEP CIVIL ENGINEERING LABORATORY
 MONITORING WELL CONSTRUCTION







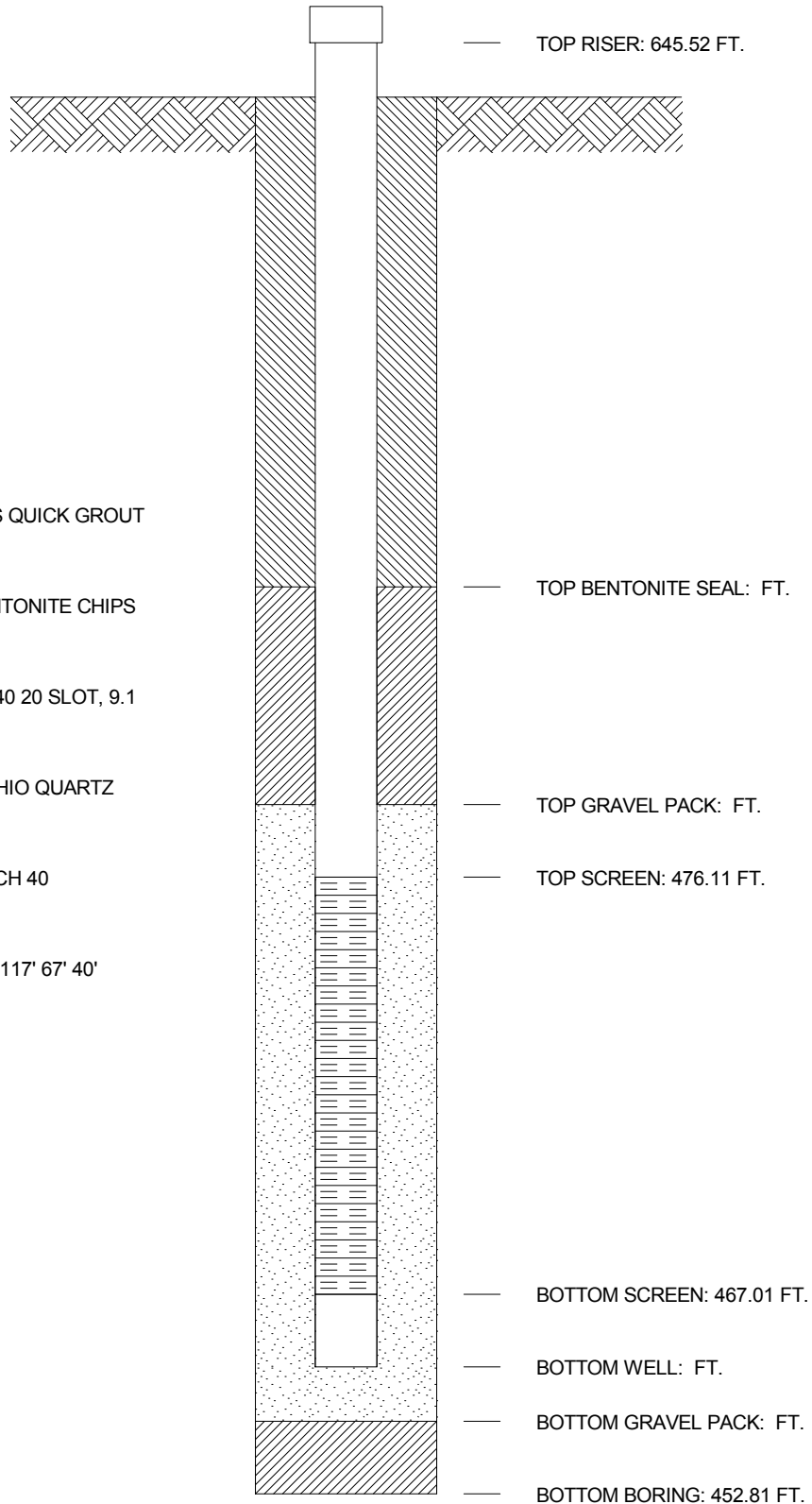

JOB NUMBER _____
 COMPANY **APPALACHIAN POWER COMPANY**
 PROJECT **MOUNTAINEER LBR LANDFILL**
 COORDINATES **N 712,296.3 E 1,700,787.8**
 SYSTEM _____

WELL No. **9632** BORING No. **96-32** INSTALLED **9/20/96**

GROUND ELEVATION 643.91 FT.



-  GROUT SEAL: 500 GALLONS QUICK GROUT
-  BENTONITE SEAL: 100# BENTONITE CHIPS
-  SCREEN: 2.0 dia., PVC SCH 40 20 SLOT, 9.1
-  GRAVEL PACK: 450# No.4 OHIO QUARTZ
-  RISER PIPE: 2.0, dia., PVC SCH 40
-  SPACERS, DEPTH: 177' 167' 117' 67' 40'

????







AMERICAN ELECTRIC POWER SERVICE CORPORATION
 AEP CIVIL ENGINEERING LABORATORY
 MONITORING WELL CONSTRUCTION



JOB NUMBER _____
 COMPANY **APPALACHIAN POWER COMPANY**
 PROJECT **MOUNTAINEER LBR LANDFILL**
 COORDINATES **N 710,919.6 E 1,699,640.4**
 SYSTEM _____

WELL No. **9633** BORING No. **96-33** INSTALLED **1/23/97**

GROUND ELEVATION 669.81 FT.

-  GROUT SEAL: 100 GALLONS QUICK GROUT
-  BENTONITE SEAL: 150# BENTONITE CHIPS
-  SCREEN: 2.0 dia., PVC SCH 40 20 SLOT, 10.0
-  GRAVEL PACK: 300# NO4 OHIO QUARTZ
-  RISER PIPE: 2.0, dia., PVC SCH 40
-  SPACERS, DEPTH: 40', 21'

????

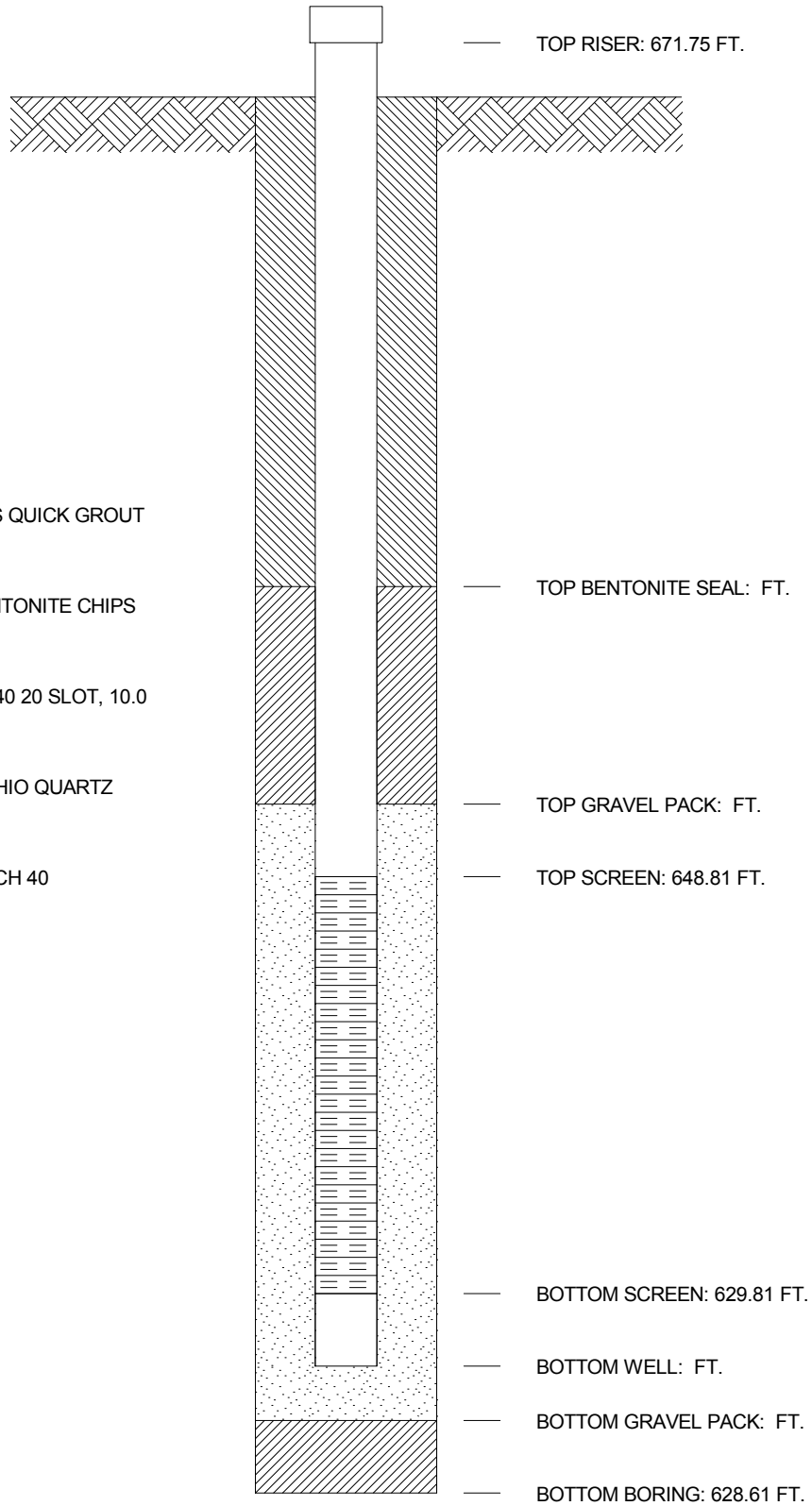

AEP 2010, 2012

**Monitoring Well Construction
Diagrams**







**MW-17A, MW-45, MW-46, MW-
46s, MW-47, MW-47s**

AMERICAN ELECTRIC POWER SERVICE CORPORATION
 AEP CIVIL ENGINEERING LABORATORY
 MONITORING WELL CONSTRUCTION



JOB NUMBER _____
 COMPANY **APPALACHIAN POWER COMPANY** WELL No. **MW-45** BORING No. **B-0901** INSTALLED **1/7/10**
 PROJECT **MOUNTAINEER LBR LANDFILL**
 COORDINATES **N 708,953.7 E 1,729,008.3**
 SYSTEM **State Plane using NAD27/29**

GROUND ELEVATION 852.23 FT.

-  GROUT SEAL: Volclay 200 Gal
-  BENTONITE SEAL: 3/8" Coated Bentonite Pellets 100#
-  SCREEN: 2.0" dia., Sch 40 20 Slot, 35.0'
-  GRAVEL PACK: #5 Quartz Sand 750#
-  RISER PIPE: 2.0", dia., Sch 40
-  SPACERS, DEPTH: 89',49',9'

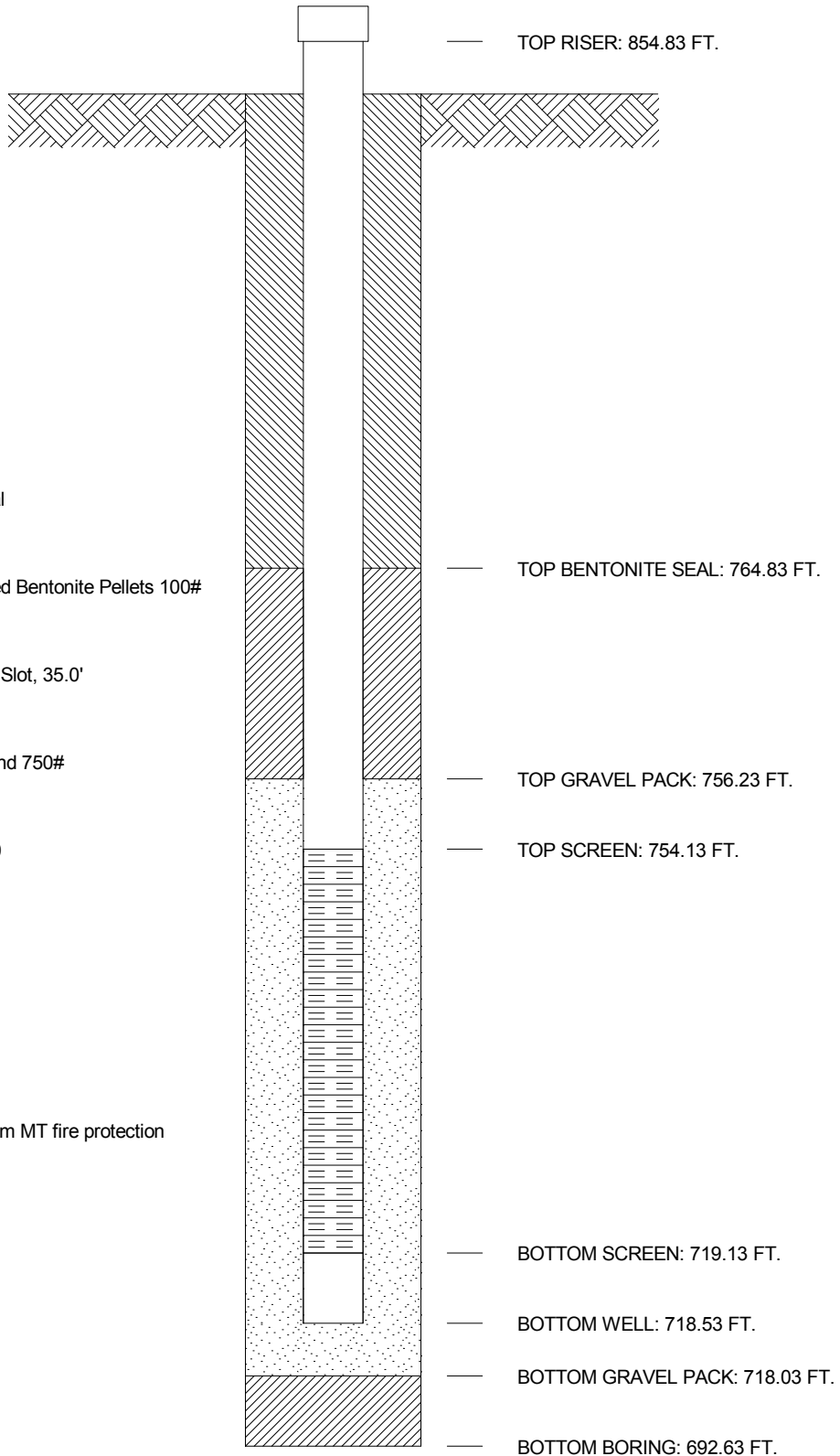

- NOTES:
- Drill & decon water coming from MT fire protection system
 - Decon drill & tools 01/14/10
 - SWL @ installation 16.1'
 - 136.0' - 134.2' cuttings
 - Drilled w/6" air hammer

AMERICAN ELECTRIC POWER SERVICE CORPORATION
 AEP CIVIL ENGINEERING LABORATORY
 MONITORING WELL CONSTRUCTION



JOB NUMBER _____
 COMPANY **APPALACHIAN POWER COMPANY** WELL No. **MW-46** BORING No. **B-0902** INSTALLED **1/19/10**
 PROJECT **MOUNTAINEER LBR LANDFILL**
 COORDINATES **N 709,192.0 E 1,728,205.5**
 SYSTEM **State Plane using NAD27/29**

GROUND ELEVATION 808.77 FT.

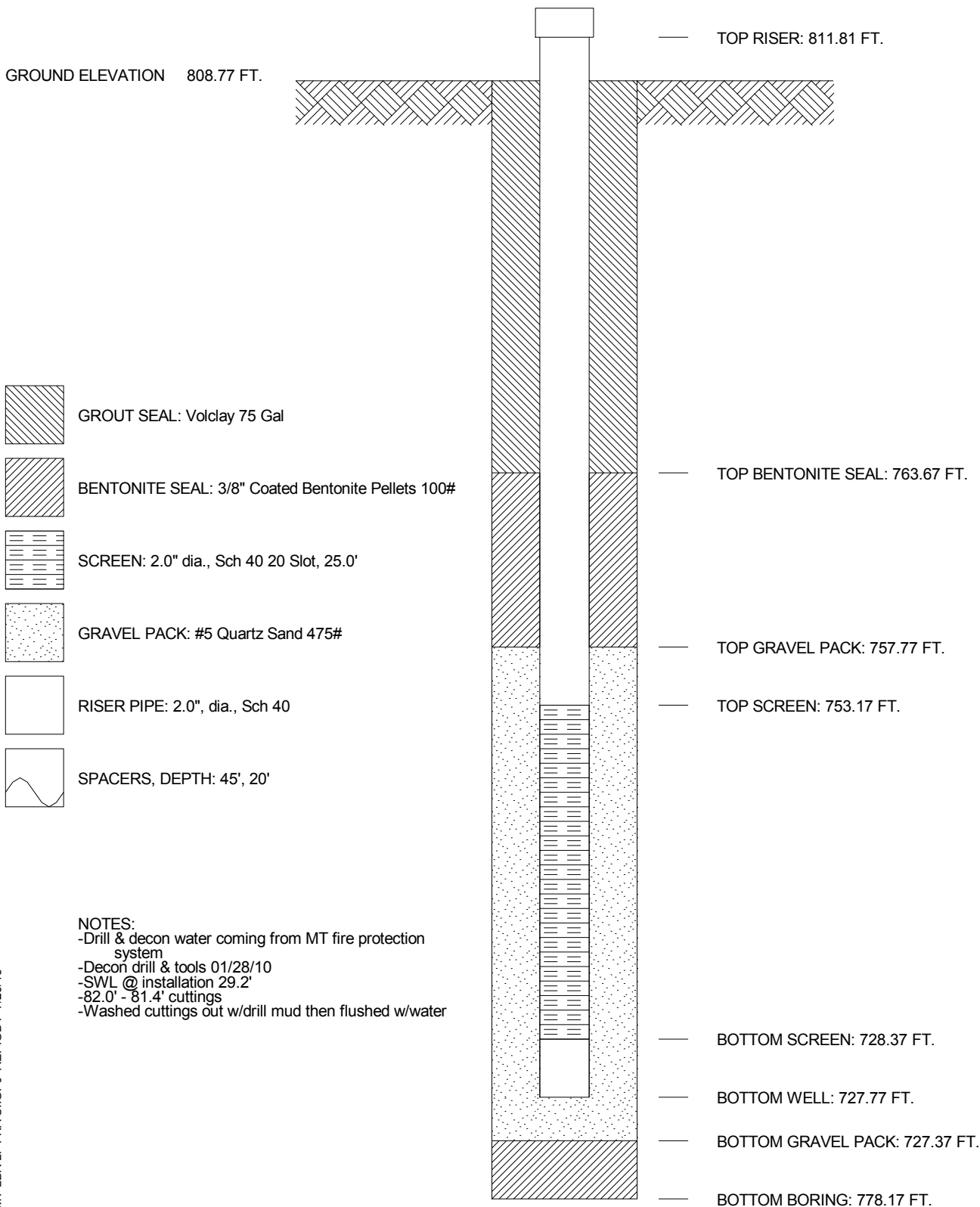







NOTES:
 -Drill & decon water coming from MT fire protection system
 -Decon drill & tools 01/28/10
 -SWL @ installation 29.2'
 -82.0' - 81.4' cuttings
 -Washed cuttings out w/drill mud then flushed w/water

AMERICAN ELECTRIC POWER SERVICE CORPORATION
 AEP CIVIL ENGINEERING LABORATORY
 MONITORING WELL CONSTRUCTION



JOB NUMBER _____
 COMPANY **APPALACHIAN POWER COMPANY** WELL No. **MW-46s** BORING No. **B-0902A** INSTALLED **1/27/10**
 PROJECT **MOUNTAINEER LBR LANDFILL**
 COORDINATES **N 709,195.5 E 1,728,209.3**
 SYSTEM **State Plane using NAD27/29**

GROUND ELEVATION 808.77 FT.

-  GROUT SEAL: Hole Plug 3/8"
-  BENTONITE SEAL: 3/8" Coated Bentonite Pellets 150#
-  SCREEN: 2.0" dia., Sch 40 PrePacked 7 Slot 40/60 Sand, 5.0'
-  GRAVEL PACK: #5 Quartz Sand 200#
-  RISER PIPE: 2.0", dia., Sch 40
-  SPACERS, DEPTH: 4'

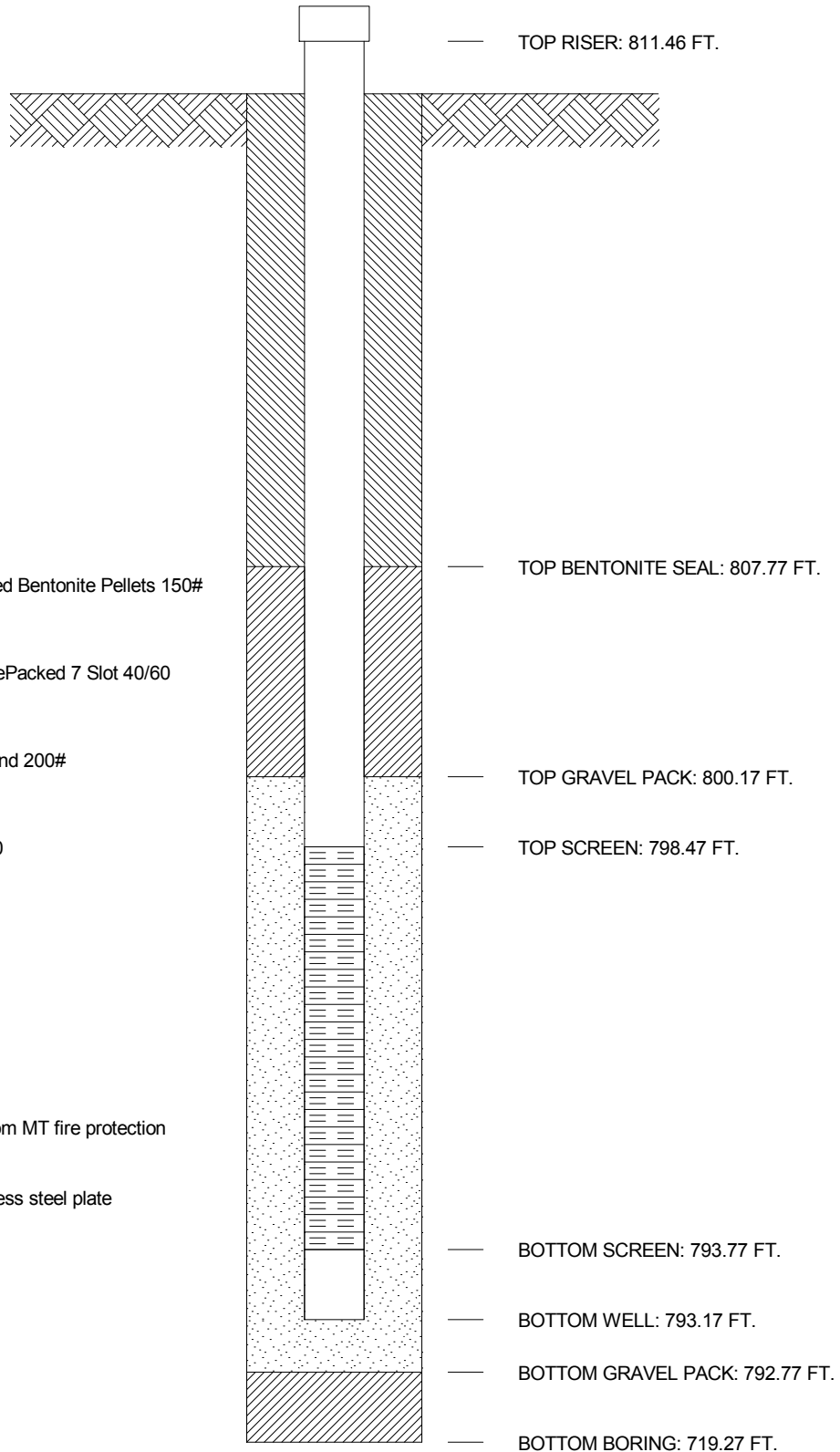

NOTES:
 -Drill & decon water coming from MT fire protection system
 -Decon drill & tools 01/29/10
 -SWL @ installation 13.8'
 -Drilled w/6.25" HSA's & stainless steel plate







AMERICAN ELECTRIC POWER SERVICE CORPORATION
 AEP CIVIL ENGINEERING LABORATORY
 MONITORING WELL CONSTRUCTION

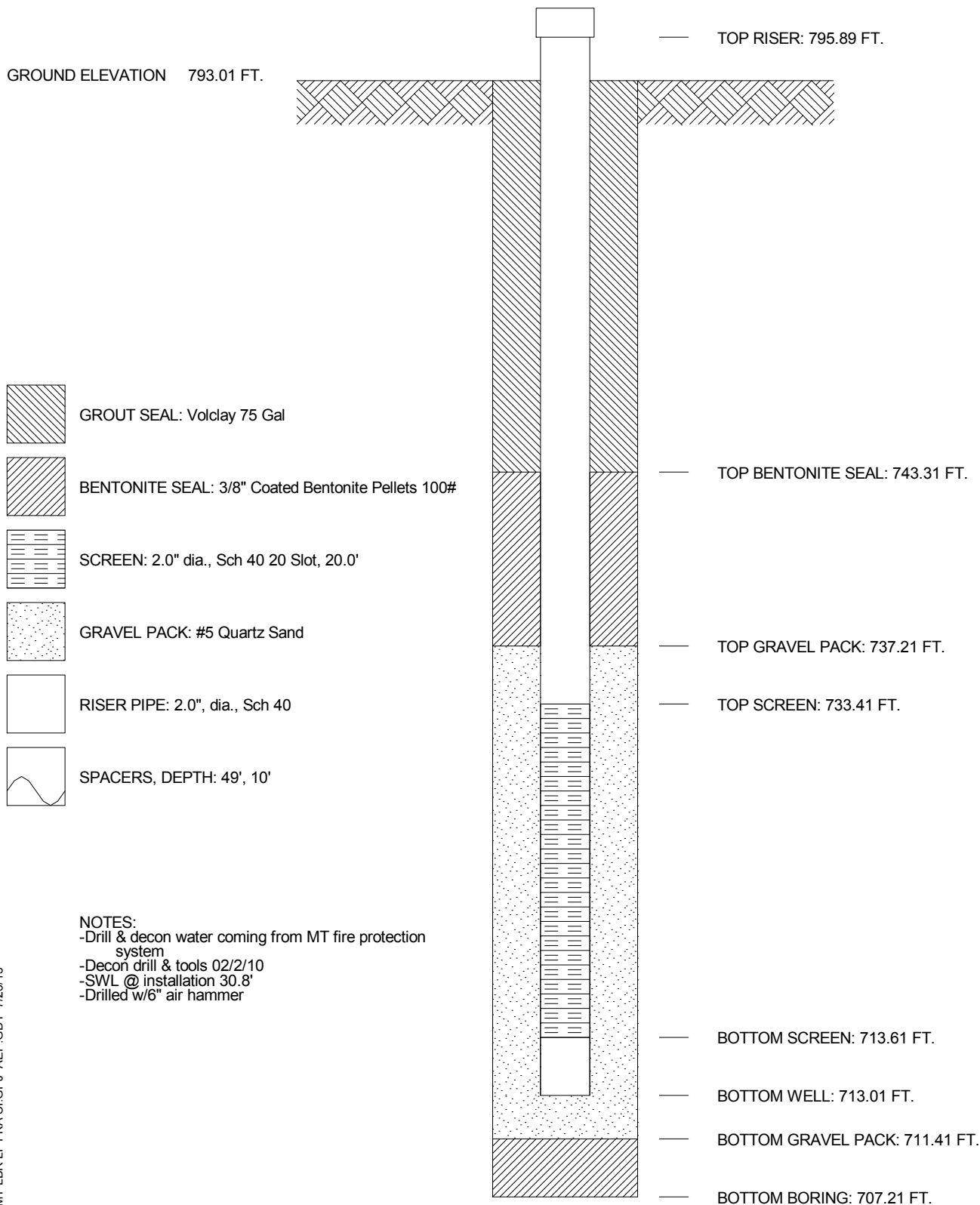

JOB NUMBER _____
 COMPANY **APPALACHIAN POWER COMPANY** WELL No. **MW-47** BORING No. **B-0903** INSTALLED **2/2/10**
 PROJECT **MOUNTAINEER LBR LANDFILL**
 COORDINATES **N 710,168.6 E 1,728,017.3**
 SYSTEM **State Plane using NAD27/29**

GROUND ELEVATION 793.01 FT.



-  GROUT SEAL: Volclay 75 Gal
-  BENTONITE SEAL: 3/8" Coated Bentonite Pellets 100#
-  SCREEN: 2.0" dia., Sch 40 20 Slot, 20.0'
-  GRAVEL PACK: #5 Quartz Sand
-  RISER PIPE: 2.0", dia., Sch 40
-  SPACERS, DEPTH: 49', 10'







NOTES:
 -Drill & decon water coming from MT fire protection system
 -Decon drill & tools 02/2/10
 -SWL @ installation 30.8'
 -Drilled w/6" air hammer

AMERICAN ELECTRIC POWER SERVICE CORPORATION
 AEP CIVIL ENGINEERING LABORATORY
 MONITORING WELL CONSTRUCTION



JOB NUMBER _____
 COMPANY **APPALACHIAN POWER COMPANY** WELL No. **MW-47s** BORING No. **B-0903s** INSTALLED **2/2/10**
 PROJECT **MOUNTAINEER LBR LANDFILL**
 COORDINATES **N 710,163.9 E 1,728,017.9**
 SYSTEM **State Plane using NAD27/29**

GROUND ELEVATION 793.01 FT.

-  GROUT SEAL: Hole Plug 3/8" 150#
-  BENTONITE SEAL: 3/8" Coated Bentonite Pellets 100#
-  SCREEN: 2.0" dia., Sch 40 PrePacked 8 Slot 40/60 Sand, 5.0'
-  GRAVEL PACK: #5 Quartz Sand 325#
-  RISER PIPE: 2.0", dia., Sch 40
-  SPACERS, DEPTH: 5'

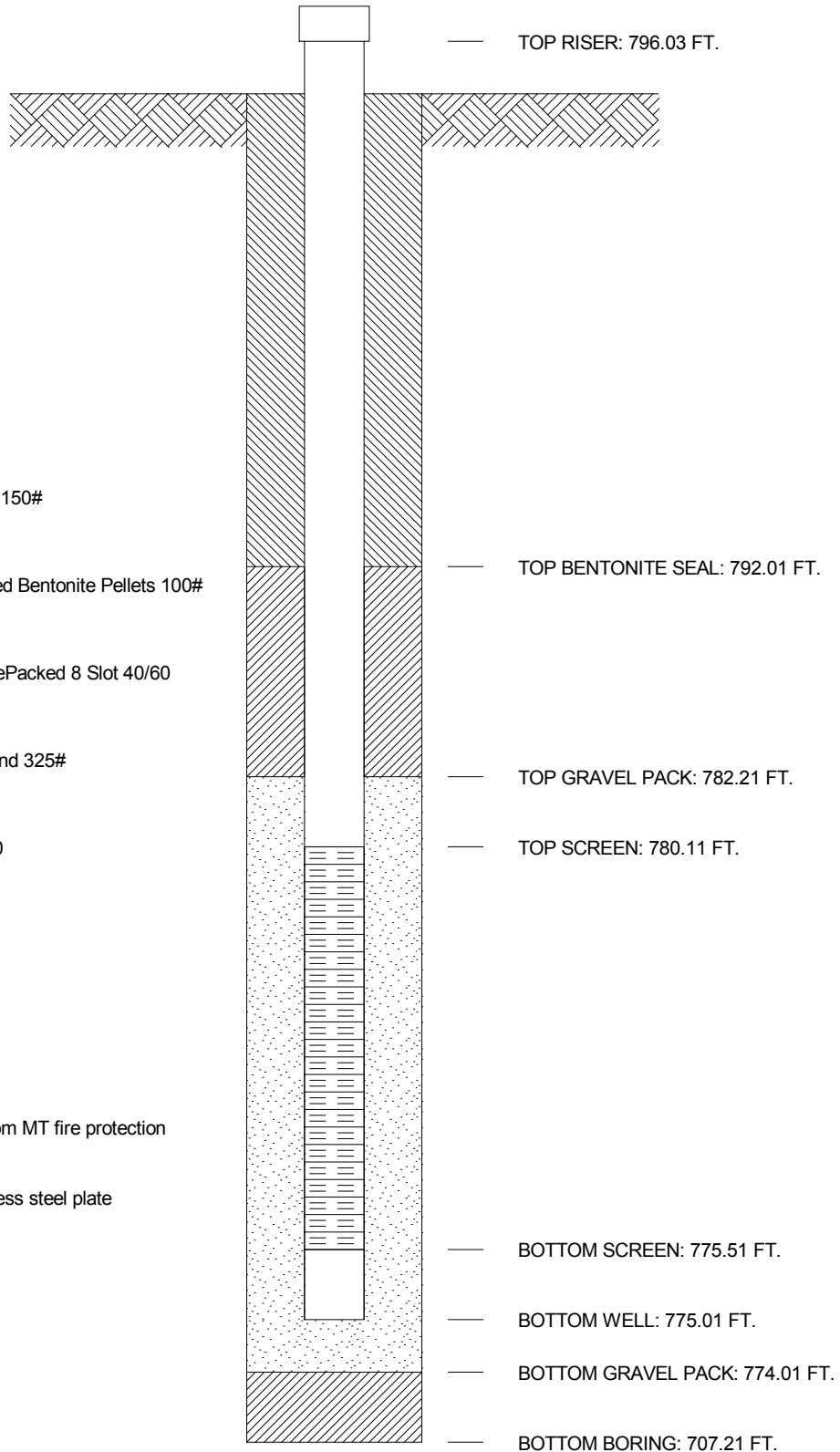

- NOTES:
- Drill & decon water coming from MT fire protection system
 - Decon drill & tools 02/4/10
 - SWL @ installation 18.1'
 - Drilled w/6.25" HSA's & stainless steel plate

AMERICAN ELECTRIC POWER SERVICE CORPORATION
 AEP CIVIL ENGINEERING LABORATORY
 MONITORING WELL CONSTRUCTION



JOB NUMBER _____
 COMPANY **APPALACHIAN POWER COMPANY** WELL No. **MW-17A** BORING No. **B-1201** INSTALLED **1/10/12**
 PROJECT **MOUNTAINEER LBR LANDFILL**
 COORDINATES **N 714,832.4 E 1,733,268.2**
 SYSTEM **State Plane using NAD27/29**

GROUND ELEVATION 621.63 FT.

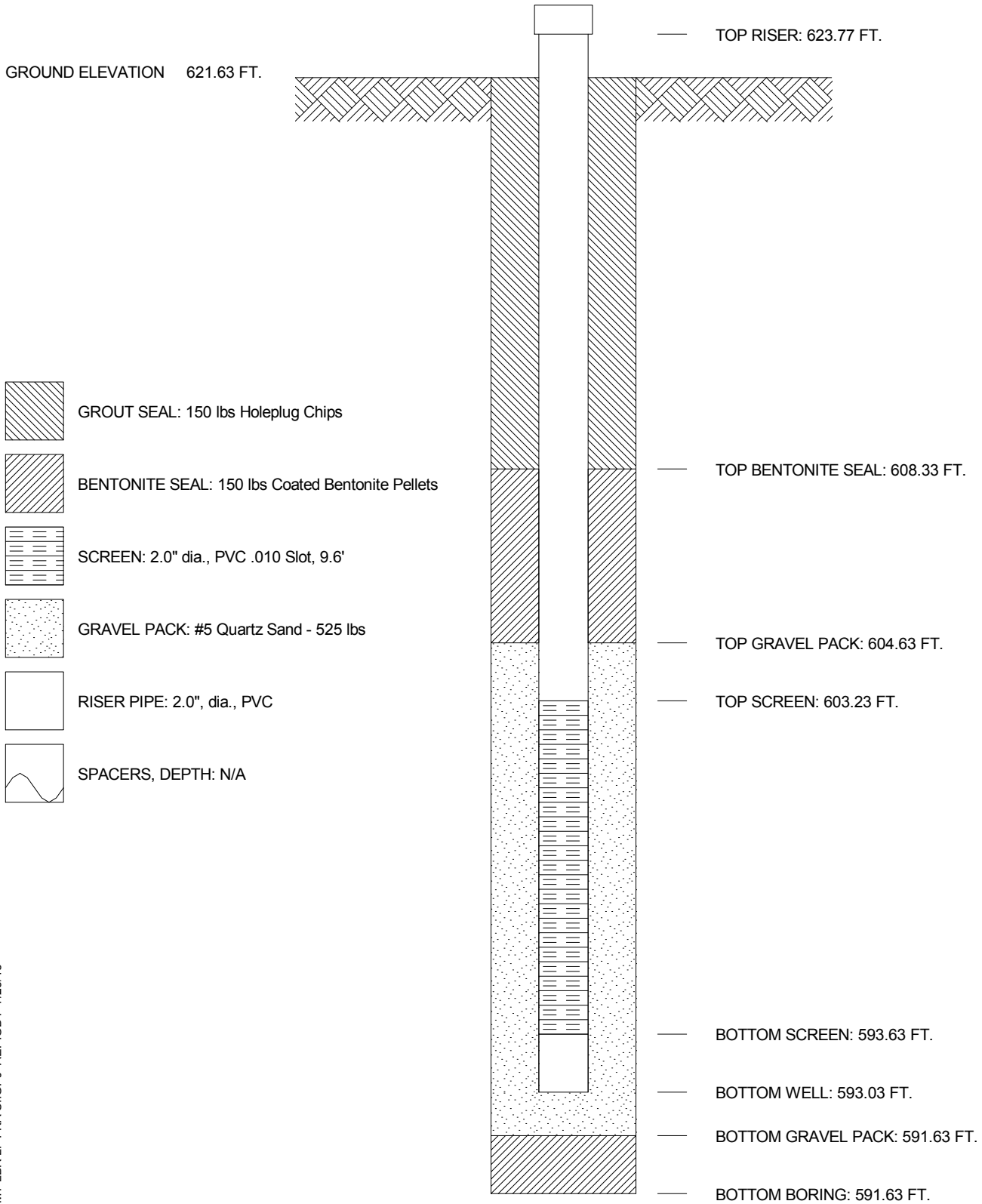



Arcadis 2016

**Monitoring Well Construction
Diagrams**

MW-1611, MW-1612

WELL CONSTRUCTION LOG
(Unconsolidated)

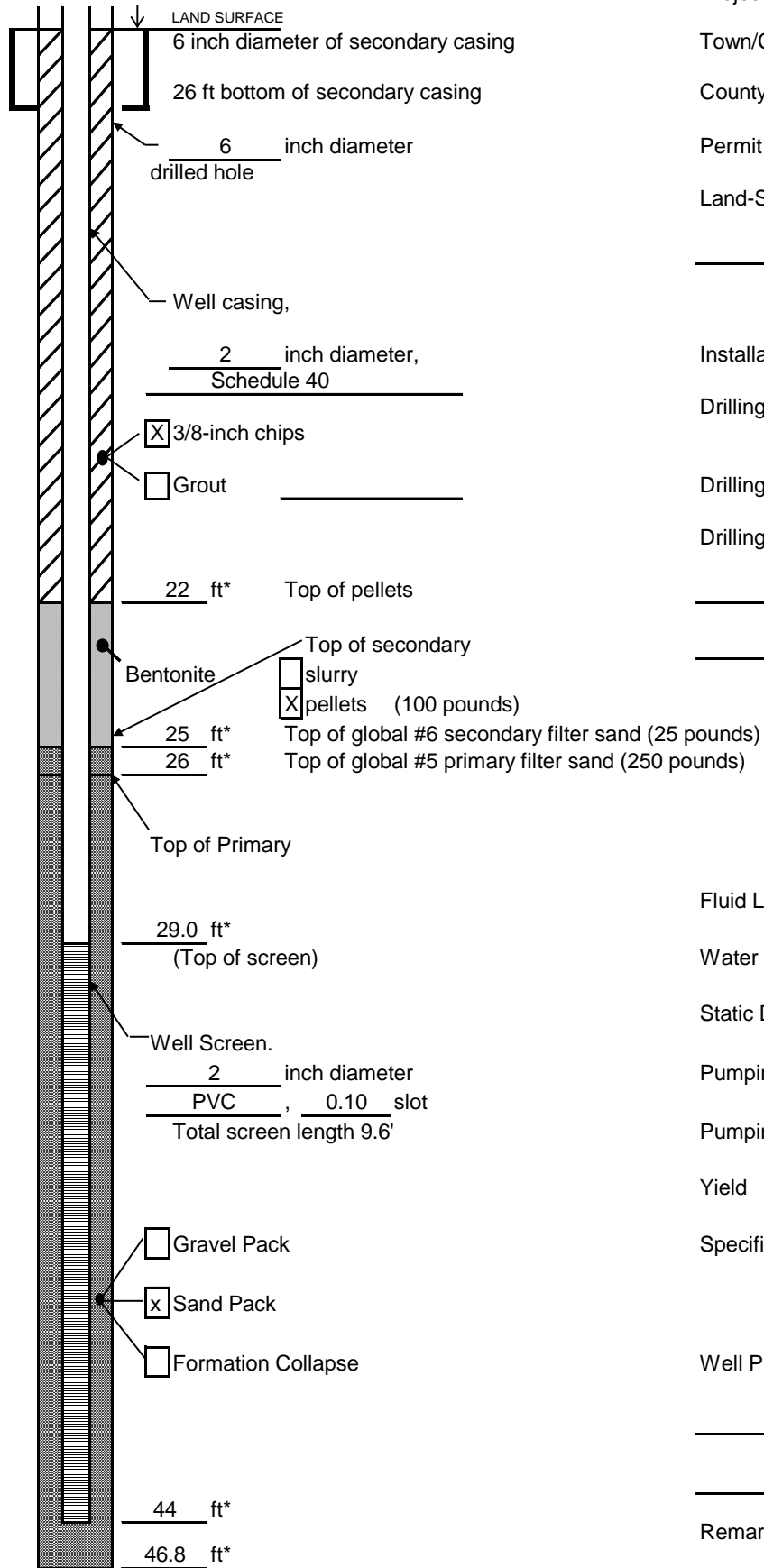

Project AEP - Mountaineer Well MW-1611
 Town/City New Haven
 County Mason County State WV
 Permit No. N/A

Land-Surface (LS) Elevation and Datum:
654.01 feet Surveyed
 Estimated

Installation Date(s) 6/23/2016
 Drilling Method Hollow Stem Auger
 Drilling Contractor DLZ Ohio, Inc.
 Drilling Fluid None

Development Technique(s) and Date(s)
Waterra and Submersible Pump (7/7 thru 7/8/16)

Fluid Loss During Drilling N/A gallons
 Water Removed During Development 70.7 gallons
 Static Depth to Water 14.10 feet below M.P.
 Pumping Depth to Water 42 feet below M.P.
 Pumping Duration NM hours
 Yield N/A gpm Date 7/7 thru 7/8/16
 Specific Capacity N/A gpm/ft

Well Purpose Monitoring well

Remarks _____

Prepared by Judd Wanner

Measuring Point is
 Top of Well Casing
 Unless Otherwise Noted.
 * Depth Below Land Surface

APPENDIX B

Banks Well Inventory Report



Prepared for:

ARCADIS U.S., INC.-Columbus
630 Plaza Drive, Suite 600
Highlands Ranch, CO 80129



Water Well Report

AEP Water Well Inventory
MOUNTAINEER PLANT
1347 GRAHAM STATION ROAD
NEW HAVEN, WV
MASON County
PO #: OH015976.0004
ES-112028
Monday, September 08, 2014



Geographic Summary	3
Maps	
Summary Map - 0.5 Mile Buffer	4
Topographic Overlay Map - 0.5 Mile Buffer	5
Current Imagery Overlay Map - 0.5 Mile Buffer	6
Water Well Details	7
Database Definitions and Sources	8
Disclaimer	9

Geographic Summary *AEP Water Well Inventory*



Location	
MASON County, WV	
Target location is 0.131 square miles and has a 1.5 mile perimeter	

Coordinates	
Longitude & Latitude in Degrees Minutes Seconds	NA
Longitude & Latitude in Decimal Degrees	NA
X and Y in UTM	NA

Elevation	
NA	

Zip Codes Searched	
Search Distance	Zip Codes (historical zip codes included)
Target Property	25253, 25247, 25264, 25265
0.5 miles	25253, 25247, 25264, 25265

Topos Searched	
Search Distance	Topo Name
Target Property	New Haven (1977)
0.5 miles	New Haven (1977)

Summary Map - 0.5 Mile Buffer

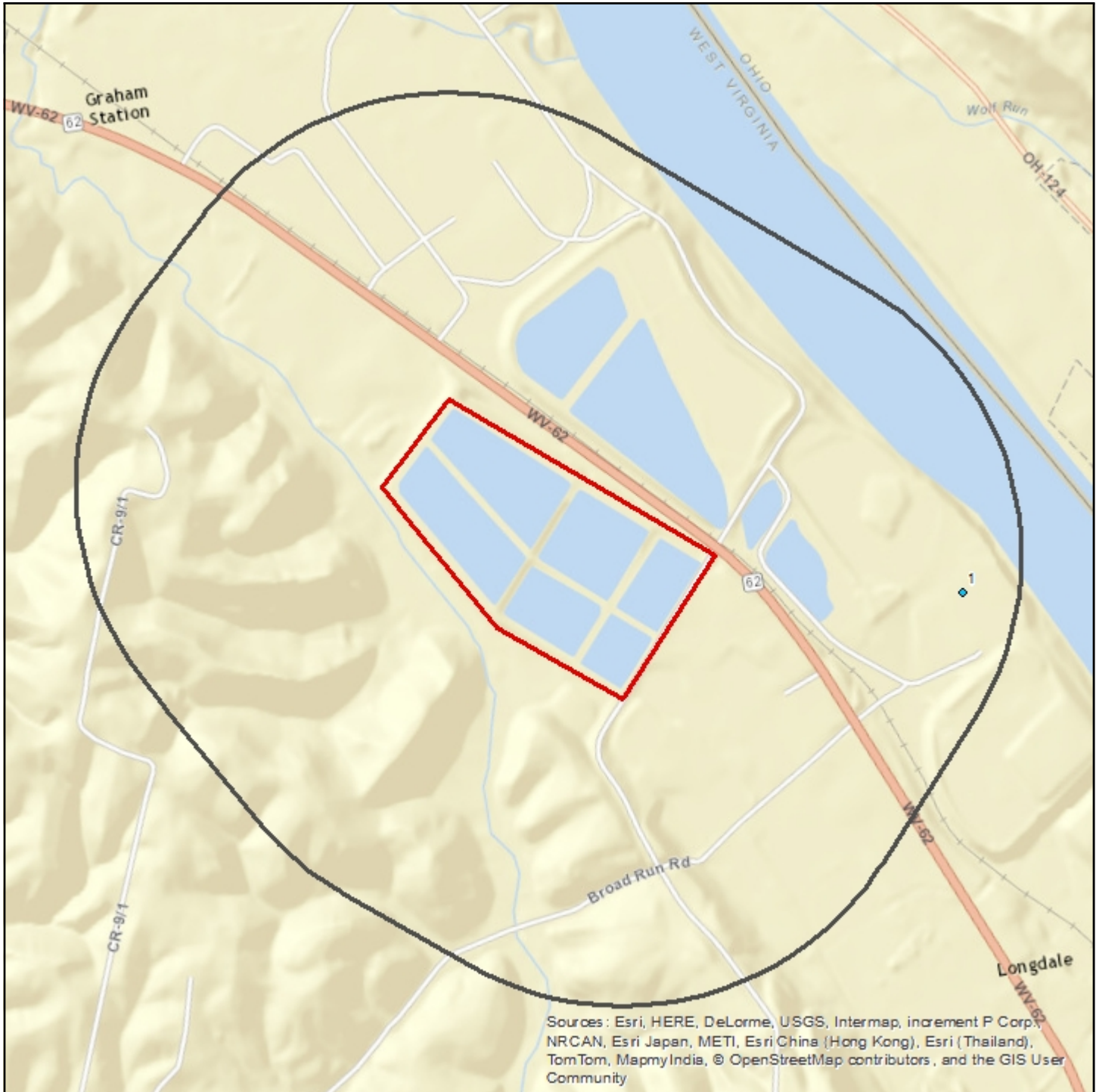

Sources : Esri, HERE, DeLorme, USGS, Intermap, increment P Corp., NRCAN, Esri Japan, METI, Esri China (Hong Kong), Esri (Thailand), TomTom, MapmyIndia, © OpenStreetMap contributors, and the GIS User Community

AEP Water Well Inventory

- Well
- Well Cluster
- Target Property
- Search Buffer

1 : 15,000
 1 inch = 0.237 miles
 1 inch = 1250 feet
 1 centimeter = 0.150 kilometers
 1 centimeter = 150 meters



Lambert Conformal Conic Projection
 1983 North American Datum
 First Standard Parallel: 33° 00' North
 Second Standard Parallel: 45° 00' North
 Central Meridian: 96° 00' West
 Latitude of Origin: 39° 00' North

Topographic Overlay Map - 0.5 Mile Buffer

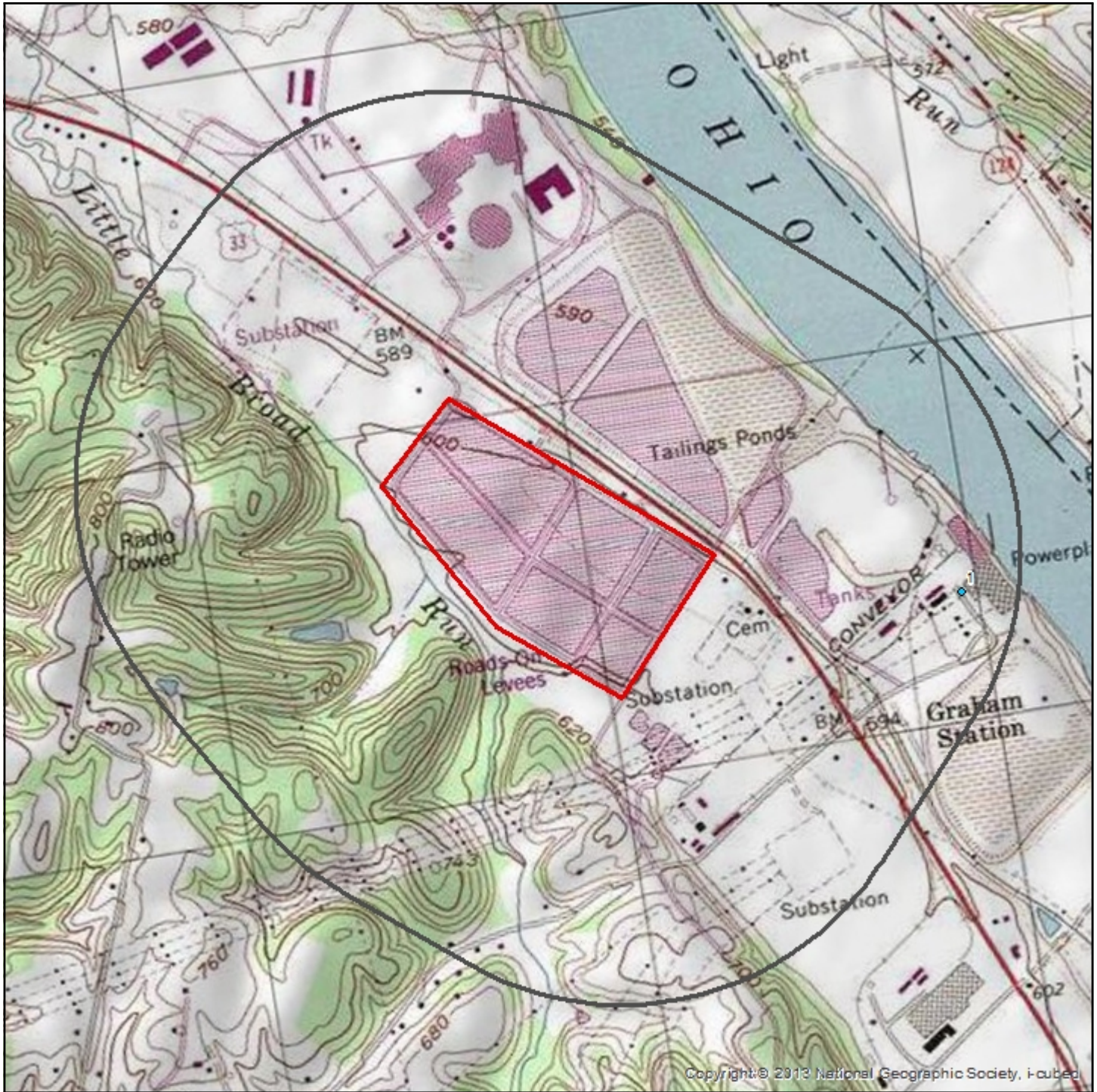

Copyright © 2013 National Geographic Society, i-cubed

AEP Water Well Inventory

- Well
- Well Cluster

- Target Property
- Search Buffer

Target Property Quad Name(s)
New Haven (1977)

1 : 15,000
1 inch = 0.237 miles
1 inch = 1250 feet

Lambert Conformal Conic Projection
1983 North American Datum
First Standard Parallel: 33° 00' North
Second Standard Parallel: 49° 00' North
Central Meridian: 96° 00' West
Latitude of Origin: 39° 00' North



Current Imagery Overlay Map - 0.5 Mile Buffer

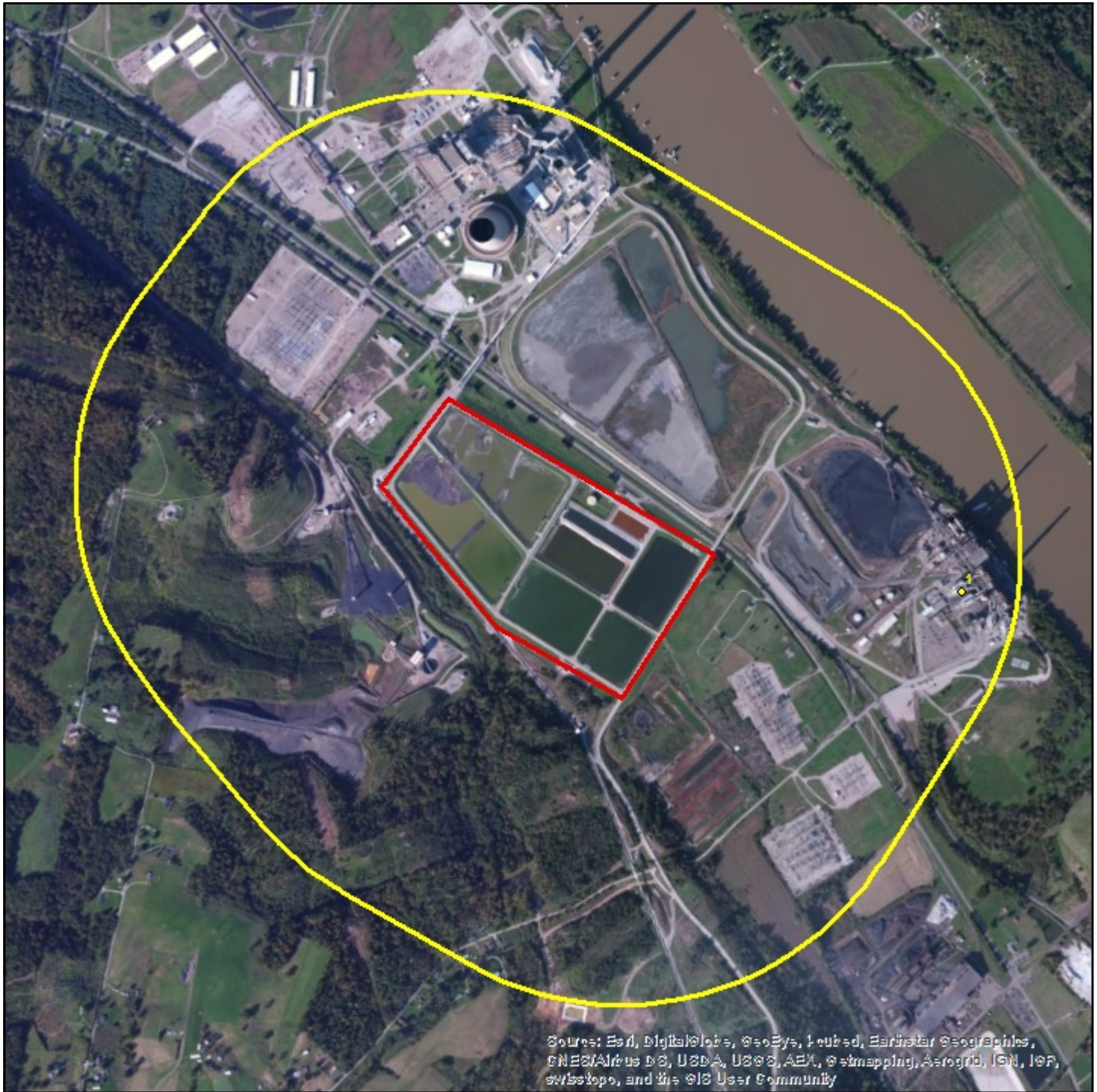

AEP Water Well Inventory

-  Well
-  Well Cluster
-  Target Property
-  Search Buffer

1 : 15,000
 1 inch = 0.237 miles
 1 inch = 1250 feet
 1 centimeter = 0.150 kilometers
 1 centimeter = 150 meters



Lambert Conformal Conic Projection
 1983 North American Datum
 First Standard Parallel: 33° 00' 00" North
 Second Standard Parallel: 45° 00' 00" North
 Central Meridian: 96° 00' 00" West
 Latitude of Origin: 39° 00' 00" North

Water Well Details *AEP Water Well Inventory*



Map ID	Source ID	Dataset	Owner of Well	Type of Well	Depth Drilled	Completion Date	Longitude	Latitude	Elevation	Driller's Logs
1	USGS-385802081552602	WW USGS	USGS	Not Reported	80	01/01/1950	-81.923748	38.967302	585 ft	N/A

Well Summary

Water Well Dataset	# of Wells
WW USGS	1
Total Count	1

Dataset Descriptions and Sources *AEP Water Well Inventory*



Dataset	Source	Dataset Description	Update Schedule	Data Requested	Data Obtained	Data Updated	Source Updated
WV WW - West Virginia Water Wells	West Virginia Department of Health and Human Resources	This dataset contains groundwater well information provided by West Virginia Department of Health and Human Resources.	As requested	N/A	N/A	N/A	N/A
OH WW - Ohio Water Wells	Ohio Department of Natural Resources	This dataset contains all historical water well records searched from Ohio Department of Natural Resources Division of Water	As requested	N/A	N/A	N/A	N/A
WW USGS - USGS Water Wells	U.S. Geological Survey	This dataset contains groundwater well records from the U.S. Geological Survey.	Quarterly	06/30/2014	06/30/2014	07/13/2014	06/30/2014

Disclaimer *AEP Water Well Inventory*



The Banks Environmental Data Water Well Report was prepared from existing state water well databases and/or additional file data/records research conducted at the state agency and the U.S. Geological Survey. Banks Environmental Data has performed a thorough and diligent search of all groundwater well information provided and recorded. All mapped locations are based on information obtained from the source. Although Banks performs quality assurance and quality control on all research projects, we recognize that any inaccuracies of the records and mapped well locations could possibly be traced to the appropriate regulatory authority or the actual driller. It may be possible that some water well schedules and logs have never been submitted to the regulatory authority by the water driller and, thus, may explain the possible unaccountability of privately drilled wells. It is uncertain if the above listing provides 100% of the existing wells within the area of review. Therefore, Banks Environmental Data cannot fully guarantee the accuracy of the data or well location(s) of those maps and records maintained by the regulatory authorities.